

## INVITATION TO BID

**Bidding package No.**

**VT-3657/25-KB**

**Title of bidding package:**

**Air winch 5 ton for Tam Dao 02 -  
Block 09-1**

**Name of the project:**

**Air winch 5 ton for Tam Dao 02 -  
Block 09-1**

**Issued on:**

\_\_\_\_/\_\_\_\_/2026

**Issued including Decision:**

# CONTENTS

Brief description

Abbreviation

## **Part 1. BIDDING PROCEDURES**

Chapter I. Instructions to bidders

Chapter II. Bidding data sheet

Chapter III. Bid proposal evaluation criteria

Chapter IV. Bidding forms

## **Part 2. TECHNICAL REQUIREMENTS**

Chapter V. Technical requirements

## **Part 3. TERMS AND CONDITIONS OF CONTRACT AND CONTRACT FORMS**

## **Part 4. APPENDICES**

## **BRIEF DESCRIPTION**

### **Part 1. BIDDING PROCEDURES**

#### **Chapter I. Instructions to bidders**

This Chapter provides information to help bidder in preparation of Bid Proposal. Information includes rules of preparation, submission of Bid Proposal, bid opening, bid evaluation and contract award. Chapter I contains provisions that are to be used without modification.

#### **Chapter II. Bidding data sheet**

This Chapter specifies in detail contents of Chapter I for applying for each bidding package.

#### **Chapter III. Bid proposal evaluation criteria**

This Chapter includes criteria for evaluation of Bid Proposal.

#### **Chapter IV. Bidding forms**

This Chapter includes forms that bidder shall complete to form a part of Bid Proposal.

### **Part 2. TECHNICAL REQUIREMENTS**

#### **Chapter V. Technical requirements**

This Chapter includes scope, progress of goods supply, technical requirements, drawing for description the specification of goods and related services; contents on inspection and testing of goods (if any).

### **Part 3. TERMS AND CONDITIONS OF CONTRACT AND CONTRACT FORMS**

#### **Chapter VI. General Conditions of Contract**

This Chapter includes general conditions applied for all contracts of various bidding packages. Chapter VI contains common provisions that are completed by awarded bidder before contract comes into effect.

#### **Chapter VII. Particular Conditions of Contract**

This Chapter includes contract data and specific conditions, which specifies detailed conditions for each contract. Particular conditions of contract are to be modified and supplemented but not to replace general conditions of Contract.

#### **Chapter VIII. Contract forms**

This Chapter includes forms which, once completed, shall become integrated part of contract. **Forms** of contract performance guarantee (Performance Bond) and Advance payment guarantee (if any) are completed by awarded bidder before contract comes into effect.

### **Part 4. APPENDICES**

- Attachment 01: Scope of supply
- Attachment 02: Technical requirements
- Attachment 03: Technical evaluation criteria
- Other technical documents, ... with link for reference (if any).

## ABBREVIATION

ITB	Instructions to Bid
BDS	Bid data sheet
GCC	General conditions of contract
PCC	Particular conditions of contract
VND	Vietnam Dong
USD	US Dollar
EUR	European currency

## Part 1. BIDDING PROCEDURES

### Chapter I. INSTRUCTIONS TO BIDDERS

<b>1. Scope of bid</b>	<p>1.1. Employer as specified in the Bid Data Sheet (BDS) issues this Invitation to Bid for selection of Bidder to implement bidding package for procurement of goods following single-stage one-envelope procedure.</p> <p>1.2. Title of the bidding package; number, quantity of parts (in case bidding package is divided into many independent parts) belongs to bidding package as specified in BDS.</p>
<b>2. Explanation of terms used in bidding</b>	<p>2.1. The Deadline for bid submission is the deadline for submission bids and is specified in the Invitation to Bid.</p> <p>2.2. Day refers to Gregorian calendar day, including weekends, holidays, and Tet holidays according to the provisions of labor law.</p> <p>2.3. Time and day, month on the national bidding network shall be defined time and day, month published the national bidding network (GMT+7).</p>
<b>3. Source of funds</b>	<p>Source of funding (or method of capital arrangement) for bidding package as specified in <b>BDS</b>.</p>
<b>4. Prohibited acts in bidding</b>	<p>4.1. Offering, giving, receiving or taking a bribe.</p> <p>4.2. Abusing positions or entrusted power to influence or illegally intervene in bidding process in any form.</p> <p>4.3. Collusive practice, including:</p> <ul style="list-style-type: none"><li>a) Reaching, with or without undue influence, an arrangement or agreement which is designed to let one or more parties to prepare bids for all bidders or to withdraw submitted bids so that one of them will win the bid;</li><li>b) Reaching an arrangement or agreement on refusal to supply goods or services, or subcontract, or reaching other agreements to limit competition so that one party will win the bid;</li><li>c) A bidder or investor with appropriate qualifications and experience has submitted a bid and meets the requirements laid down in the Invitation to Bid but deliberately refuses to provide additional documents proving their capacity and experience at the Vietsoyepetro's request for clarification of the bid or verification of their submitted documents with the aim of facilitating one party's winning of the bid.</li></ul> <p>4.4. Fraudulent practice, including:</p> <ul style="list-style-type: none"><li>a) Forging or falsifying information and/or documents used in bidding;</li><li>b) Deliberately providing information and documents which are not accurate or objective in bids or proposals with the aim of falsifying the contractor selection result.</li></ul> <p>4.5. Obstructive practice, including:</p> <ul style="list-style-type: none"><li>a) Destroying, deceiving, altering or concealing of evidence or making false statements; threatening, harassing or intimidating any party to prevent the verification or investigation into a corrupt, fraudulent or collusive practice made with a supervision, inspection or audit authority;</li></ul>

- b) Obstructing the competent person, employer, Vietsovpetro, bidders in the course of contractor selection;
- c) Impeding competent authorities' rights of supervision, inspection or audit of bidding activities;
- d) Deliberately making false complaints, denunciations or petitions with the aim of impeding bidding process;
- e) Acts of violation against laws and regulations on cybersecurity and safety intended to intervene or impede the online bidding process.

4.6. Inequality and non-transparency, including:

- a) A bidder of a package or investment project is also the Vietsovpetro or employer or takes charge of performing tasks of the Vietsovpetro or employer of that package or investment project, violating against the regulations stated in Point 5 ITB;
- b) A person or entity concurrently engages in the preparation and appraisal of Invitation to Bid, or RFP of the same package or investment project;
- c) A person or entity concurrently engages in the evaluation of bids or proposals and the appraisal of the contractor selection result of the same package or investment project;
- d) A person who is working for the Vietsovpetro/employer directly engages in the contractor selection, or acts as a member of the expert team or appraising team in charge of appraising the contractor selection result, or is a competent person or head of the Vietsovpetro/employer, for a package or investment project for which his/her family relative, as defined in the Law on enterprises, directly submits a bid or acts as the legal representative of a bidder;
- e) A bidder submits a bid for a procurement, construction or non-consulting service package for which the bidder is also acting as a consultant on preparation, verification and appraisal of cost estimate, technical design, building drawings and designs, front-end engineering design (FEED); preparation and appraisal of Invitation to Bid; evaluation of bids; inspection of goods; appraisal of contractor selection result; supervision of contract execution;
- f) A person acts as a bidder for a package of a project or investment project of the Vietsovpetro or employer for which he/she worked and held the executive or managerial position within 12 months from the date of his/her resignation therefrom;
- g) A supervision consultant also acts as the inspection consultant of the same package;

4.7. Unauthorized disclosure of the following information and documents on the contractor/investor selection:

- a) Contents of bidding documents before they are issued as prescribed;
- b) Contents of Bids, notebooks, minutes of bid evaluation meetings, comments and evaluations for each Bids before publishing contractor selection result;
- c) Content of request for clarification of Bid proposals of the Vietsovpetro and responses of bidders during the evaluation process of Bid proposals before publishing the bidder selection result;

	<p>d) Report of the Vietsovpetro, report of the Expert Group, appraisal report, report of consulting bidder, report of relevant professional authorized organization during the bidder selection process before publishing the bidder selection result;</p> <p>e) The bidder selection result before being published according to regulation as prescribed.</p> <p>4.8. Illegal transfer of awarded contract: The contractor transfers to other contractor(s) a workload of task of the package worth more than 10% of package value; or worth less than 10% of package value but more than 02 million USD (after deducting the workload of the subcontractor's responsibility as declared in the contract), calculated on the signed Contract price.</p>
<p><b>5. Eligibility of bidders</b></p>	<p>A bidder that is an organization shall be deemed to be eligible if complying the following requirements:</p> <p>a) It is required to have registration of establishment and operation issued by the competent authority of the country where the bidder is operating;</p> <p>b) It must keep independent accounting records;</p> <p>c) It is not undergoing dissolution process or subject to revocation of enterprise registration certificate, cooperative/cooperative union/artel registration certificate; is not facing insolvency as prescribed by the law on bankruptcy;</p> <p>d) It must ensure competitiveness in bidding as prescribed in Point BDS;</p> <p>e) It is not being prohibited from participating in bidding;</p> <p>f) It is not liable to criminal prosecution;</p> <p>g) It is not the state of temporary suspension, termination of participation in national bidding network;</p> <p>h) It is name is registered on National bidding network before the grant of approval for contractor selection result as prescribed in BDS.</p>
<p><b>6. Contents of Invitation to Bid</b></p>	<p>6.1. The Invitation to Bid consists of Parts 1, 2, 3, 4 accompanied with documents of Bid Proposal amendment as specified in ITB 7 (if any) including as follows:</p> <p><b>Part 1. Bidding Procedures:</b></p> <ul style="list-style-type: none"> <li>- Chapter I. Instructions to Bidders (ITB);</li> <li>- Chapter II. Bidding Data Sheet (BDS);</li> <li>- Chapter III. Bid Proposal Evaluation Criteria;</li> <li>- Chapter IV. Bidding Forms.</li> </ul> <p><b>Part 2. Technical Requirements:</b> Chapter V. Technical Requirements.</p> <p><b>Part 3. Conditions and Forms of Contract:</b> This part includes the terms, conditions, data and forms that constitute the complete contract.</p> <p><b>Part 4. Appendices</b></p> <p>6.2. Vietsovpetro is not responsible for the preciseness, completeness of the Invitation to Bid, explanation for clarification documents or amendment of Invitation to Bid as prescribed in ITB</p>

	<p>7 if these documents are not provided by Vietsovpetro. In case of any contradiction, documents issued by Vietsovpetro shall prevail.</p> <p>6.3. The bidder shall examine all instructions, forms, supply requirements and other requirements in the Invitation to Bid for preparation Bid Proposal including all information or documentation as required by the Invitation to Bid.</p>
<b>7. Clarification and amendment of Invitation to Bid</b>	<p>7.1. The amendment of the Invitation to Bid shall be made as prescribed in <b>BDS</b> prior to the deadline for submission of bid proposal by issuing the written documentation for amendment in accordance with the methods as prescribed in <b>BDS</b>. To give bidders reasonable time in preparing their bid proposal, Vietsovpetro may, at its discretion, extend the deadline for the submission of bid proposals.</p> <p>7.2. Any bidder who needs clarification of the ITB shall send a written request to Vietsovpetro in a minimum period of time as prescribed in the <b>BDS</b> prior to date of Deadline for bid submission in order that Vietsovpetro shall take consideration. After receiving the written request for clarification by the deadline, Vietsovpetro shall make a written clarification response in a minimum period of time as prescribed in <b>BDS</b>, that specifying clarification content request without specifying the name of the requesting bidder, and send it to every bidder who have received the ITB from the Vietsovpetro. If the clarification leads to amendment ITB, Vietsovpetro shall amend the ITB in accordance with ITB 7.1.</p> <p>7.3. If necessary Vietsovpetro hold pre-bidding conference to discuss the contents in Bidding Document in which the bidders are unclear as stipulated in <b>BDS</b>. Vietsovpetro shall send an invitation to the pre-bidding conference to all contractors who have received the Invitation to Bid and post it on the System. The discussion shall be formally recorded as minutes of clarification which shall be sent to all bidders who have bought or acquired Invitation to Bid from Vietsovpetro.</p> <p>7.4. In case the Invitation to Bid is required to be modified after the pre-tender conference, Vietsovpetro shall issue a written document for amendment as specified in ITB 7.1, minutes of pre-bidding conference is not the amendment of Invitation to Bid.</p> <p>7.5. No participation in pre-bidding conference or without a confirmation letter that bidder having participated in pre-bidding conference is not the reason to reject the Bid proposals' bidder.</p>
<b>8. Cost of bidding</b>	The bidder shall bear all costs associated with the preparation and submission of its Bid Proposal. Vietsovpetro shall not be liable for those cost under any circumstances.
<b>9. Language of Bid Proposal</b>	The bid proposal, as well as all correspondence and documents relating to the bid proposal exchanged by the bidder and Vietsovpetro, shall be written in English. Any supporting documents in bid proposal can be written in other languages and concurrently attached with translation in English. In case of no translation, if necessary, Vietsovpetro may ask bidder for supplementation of documents.
<b>10. Documents comprising the Bid Proposal</b>	<p>The Bid Proposal shall comprise of the following:</p> <p>10.1. Application for bidding in accordance with ITB 11;</p>

	<p>10.2. Consortium agreement in case the bidder is Consortium in accordance with <a href="#">Form 03</a>, Chapter IV – Bidding forms;</p> <p>10.3. Bid Bond, in accordance with ITB 18;</p> <p>10.4. Proof documents for eligibility of bidder in accordance with ITB 5;</p> <p>10.5. Proof documents for eligibility of signatory under the application for bidding, in accordance with ITB 20.3;</p> <p>10.6. Proof documents for capacity and experience of bidder, in accordance with ITB 16;</p> <p>10.7. Technical proposals and proof document for adequacy of goods and related services, in accordance with ITB 15;</p> <p>10.8. Price proposals and price schedules with full information, in accordance with ITB 11, 13;</p> <p>10.9. Proposals of technical alternatives, in accordance with ITB 12 (if any);</p> <p>10.10. Other contents as specified in <b>BDS</b>.</p>
<b>11. Application for bidding form and price schedules</b>	The application for bidding form and respective price schedules shall be prepared using the relevant forms furnished in Chapter IV, Bidding Forms.
<b>12. Proposals of technical alternatives</b>	<p>12.1. In case Invitation to Bid stipulates in <b>BDS</b> for probability of technical alternatives, then those technical alternatives shall be considered.</p> <p>12.2. Technical alternatives are only considered when main solution meets requirements and bidder is ranked first. In this case, bidder shall provide all information necessary for evaluation of the alternatives by Vietsovpetro, including: notes, drawings, technical specifications, progress of supply, costs and other relevant information. The evaluation of technical alternatives in accordance with Section 5, Chapter III.</p>
<b>13. Bidding prices and discounts</b>	<p>13.1. Bidding price stated in the Application for bidding and in the bidding price tables with discounts must comply with the regulations as specified in this Section:</p> <p>a) The bidding prices means the price stated in Application for bidding, including all costs for implementation of bidding package (not including discounts).</p> <p>b) In case the bidding packages is not divided into independent parts, on condition that bidder offers discount, this can be offered directly in Application for Bidding or put in separate letter for discount. Bidder has to specify the content of discount and details of discount allocation into specific items in columns of “List of goods”, “Services description”. In case details are not provided, the discount is assumed to apply uniformly for all items in the columns of “List of goods”, “Services description”. Letter for discount (if any) can be submitted with Bid Proposal or separately provided that Vietsovpetro receive prior to Deadline for bid submission.</p> <p>c) Bidder shall submit Bid Proposal for all work described in ITB 1.1 and offer unit prices, extended amount for work specified in columns of “List of goods”, “Services description” in accordance with respective <a href="#">Form</a> prescribed in Chapter IV – Bidding forms.</p> <p>In case columns “Unit price” and “Extended amount” are not offered or offered “0”, it is assumed that bidder allocates prices of</p>

	<p>these goods and services into others prices of those in bidding package, bidder is responsible to provide goods, services in accordance with requirements of Invitation to Bid and not receive payment from Vietsovptero during implementation of contract. Bidder is required to offer prices in each Price schedules as prescribed in <b>BDS</b>.</p> <p>13.2. In case bidding package is divided into independent parts and bidder is allowed bidding in each part specified in BDS, bidder is able to bid for one or many parts of bidding package. Bidder has to bid all work of such part which the bidder attends. Should the bidder offer discount, bidder shall specify details and prices of discount in each part as per ITB 1.2.</p> <p>13.3. The bidder shall be responsible for the bidding price quoted to perform and complete the work in accordance with the requirements as stated in the Invitation to Bid. In case the bidder offer a low unit price in abnormal manner which affecting to the quality of the bidding package, the Vietsovpetro may require the bidder to clarify the feasibility of such abnormal unit price.</p> <p>13.4. Bidder's bidding price quoted shall include all taxes, fees and charges (if any) in response to tax rates, expenses, fees at the time of 28 days prior to the stipulated deadline for bid submission. In case bidders announce bidding prices not including taxes, fees, charges (if any), bidders' Bid Proposal shall be rejected.</p> <p>13.5. Bidders offer the bidding price as stipulated in <b>BDS</b>.</p>
<p><b>14. Currencies of Bid and payment</b></p>	<p>14.1. The currency of the bid shall be offered in <i>VND/ USD/ EUR</i>. Cost incurred inside Vietnam shall be offered in VND. Cost incurred outside Vietnam shall be offered in <i>VND/ USD/ EUR</i>. Bidders have to offer by only one currency for a specific work. In case bidding price is offered in foreign currency, bidder has to prove that the respective work has been using foreign currency.</p> <p>14.2. The currency of payment for work items shall correspond with the currency of bid for those items. Domestic costs are only paid in VND.</p> <p>14.3. The currency for conversion of different bidding prices from various currencies into unique currency for evaluation and comparison is: VND/USD applying the selling rate stated by Vietcombank on the date when the bid is closed. If all bidding prices are in foreign currency, then bid evaluation and comparison shall be done in USD. In the event that one of bidding prices is in VND, then bid evaluation and comparison shall be done in VND.</p> <p>14.4. Without prejudice to any terms mentioned above and relevant applicable laws, contract currency for domestic bidders shall be in VND, applying the selling rate stated by Vietcombank on the date when the bid is closed.</p>
<p><b>15. Documents establishing the conformity of the Goods and related services</b></p>	<p>15.1. To establish the eligibility of the goods and related services in accordance with Invitation to Bid, the bidder shall furnish as part of its Bid Proposal the documentary evidence that the goods conform to the technical specifications and standards specified in Chapter V.</p> <p>15.2. The term "Goods" is construed including but not limited to machinery, equipment, raw materials, fuel, materials, supplies,</p>

	<p>accessories; consumables; medical supplies used for medical establishment.</p> <p>15.3. The term “origin” shall mean as country or territory where produces whole goods or implements final basic processing in case many countries or territories take part in production process of those goods.</p> <p>15.4. The term “Related Services” including but not limited to the Services such as: warranty, maintenance, overhaul, repair, supply of spare parts or supply of other after sales services like training, technology transfer, ...</p> <p>15.5. The documentary evidence responsiveness of the goods and related services may be in the form of documents, drawings, data, and shall consist of a detailed item by item description of the essential technical and performance characteristics of the goods and related services, demonstrating substantial responsiveness of the goods and related services to the technical specification, and if applicable, a statement of deviations and exceptions to the provisions of the Chapter V.</p> <p>15.6. The bidder shall also provide a list giving full particulars, current prices of spare parts, special tools, etc., necessary for the proper and continuing functioning of the goods during the period specified in the <b>BDS</b> following commencement of the use of the goods.</p> <p>15.7. Standards for manufacturing, production process of material and equipment, as well as references to brand names or catalogue numbers specified by Vietsovpetro in the Chapter V, are intended to be descriptive only and not restrictive to bidder. The bidder may offer other standards of quality, brand names, catalogue numbers, provided that it demonstrates, to Vietsovpetro’s satisfaction, that the substitutions ensure substantial equivalence or are superior to those specified in the Chapter V.</p>
<p><b>16. Documents establishing the capacity and experiences of the bidder</b></p>	<p>16.1. The bidder shall provide necessary information in <b>Forms</b> in Chapter IV – Bidding Forms in order to demonstrate capacity and experiences for performance of contract as specified in Chapter III – Bid Proposal evaluation criteria. The bidder shall prepare original documents for verification with information stated in bidder’s Bid proposal if Vietsovpetro requires.</p> <p>16.2. The documentary evidence of the bidder’s capacity to perform the contract if its bid proposal is awarded as specified in <b>BDS</b>.</p>
<p><b>17. Period of validity of Bid Proposal</b></p>	<p>17.1. Bid Proposal shall remain valid not shorter than the period specified in the <b>BDS</b>.</p> <p>17.2. In exceptional circumstances, prior to the expiration of the bid proposal’s validity period, Vietsovpetro may request bidders to extend the period of validity of their Bid Proposal. The Bid Bond as also requested shall be extended for 30 days beyond the deadline of the extended validity period. If a bidder refuses to extend its Bid Proposal validity as required, the Bid Proposal shall not be further considered and the Bid Bond shall be returned to bidder. The bidder have accepted Vietsovpetro’s extension request shall not be permitted to modify any contents of its Bid Proposal. The extension request and acceptance or non-acceptance shall be in writing.</p>

## 18. Bid Guarantee

18.1. When attending the bid, prior to deadline for bid submission, the bidder shall implement bid guarantee and attach it to Bid proposal under the following forms:

- i) a form unconditional guarantee issued by a bank or financial institution which is legally operating in Vietnam or foreign bank branches established under Vietnamese law;
- ii) submit a certificate of insurance guarantee issued by a domestic non-life insurance enterprise, or branch of a foreign non-life insurance enterprise established under the Vietnamese law;
- iii) pay a deposit or bank transfer to VSP's account as specified in **BDS 18.2**.

In case the validity of Bid proposal is extended as specified in ITB 17.2, the Bid bond's validity shall be accordingly extended. In case of consortium bidder, all partners of consortium shall implement the same form of Bid bond.

In case of Consortium, the Bid Bond shall comply with one of the following:

- a) Each Consortium partner shall provide a separate Bid Bond; however, the aggregate amount of Bid Bond submitted by all Consortium partners is not less than the required amount specified in ITB 18.2. If the Bid Bond of any Consortium partner is determined to be invalid, the bid of the Consortium shall not be considered and evaluated further. If any Consortium partner is in breach of the rules resulting in without return of Bid Bond in accordance with point b ITB 18.5, then Bid bond of all Consortium partners shall not be returned.
- b) All partners of the Consortium shall nominate one partner to arrange a single Bid Bond for itself and all other partners in the Consortium. In this case, the Bid Bond shall be in the name of the Consortium or the name of the partner who arranges the Bid Bond for the entire Consortium provided that the total amount is not less than the required amount in BDS of ITB 18.2. If any Consortium partner is in breach of the rules resulting in without return of the Bid Bond in accordance with ITB 18.5, the Bid Bond shall not be returned.

18.2. Amount, currency and valid period of the Bid Bond shall be as specified in the **BDS**.

18.3. The Bid Bond shall be considered illegitimate in one of following cases: having lower value, with shorter valid period as specified in ITB 18.2, **incorrectly states the name of the beneficiary**, not original and without legitimate signature, signed before Vietsovetro issues the Invitation to Bid or accompanied with adverse condition for Vietsovetro (including not fully committed with content of the Bid Bond Forms – 04A, 04B, 04C in Chapter IV). In case of using a letter of guarantee or certificate of insurance, the letter of guarantee or certificate of insurance must be provided, signed and stamped (if applied) by one of the following: a lawful representative of a domestic credit institution, a branch of a foreign bank established under Vietnamese law, a domestic non-life insurance enterprise, a branch of foreign non-life insurance enterprise established under Vietnamese law. In case of using a letter of guarantee (of deposit/transfer to Vietsovetro's account), the letter must be signed and stamped by the legal representative of

	<p>the contractor.</p> <p>18.4. Unsuccessful bidder shall be returned or released the Bid Bond in the maximum duration specified in the <b>BDS</b> since the date for notification of result of selecting bidder. For successful bidder, the Bid Bond shall be returned or released after the bidder furnishes the contract performance guarantee.</p> <p>18.5. The Bid Bond shall not be returned in one of following cases:</p> <p>a) After the deadline for submission of bids and during the validity period of the bid, the bidder withdraws their Bid proposals or gives a written refusal to perform one or some tasks proposed in their Bid proposals in accordance with the requirements laid down in the Invitation to Bid;</p> <p>b) The bidder performs any of the prohibited acts specified in Point 4 ITB or commits violations of the bidding law resulting in bid cancellation as prescribed in Point 32 ITB;</p> <p>c) The successful bidder fails to furnish the required performance security as prescribed Point 37 ITB; The first ranked bidder is invited to negotiate the Contract. Within seven (07) days from the date of receipt of the invitation to negotiate the Contract from Vietsovpetro, the bidder does not come to negotiate or refuses to negotiate the Contract or offers conditions different from the content in the Bid Proposals or withdrawing commitments in the Bid Proposals resulting to unsuccessful Contract negotiations, the Bid bond shall be not returned to bidder, except in cases of force majeure;</p> <p>d) The bidder fails or refuses to complete the Contract within twenty (20) days from the date of receipt of notification of Bid award from Vietsovpetro, except in cases of force majeure;</p> <p>e) The bidder refuses to sign the Contract within ten (10) days from the date of completion of the Contract, except in cases of force majeure.</p> <p>18.6. In case the Invitation to Bid is divided into independent parts, bidder may submit the bid bond in either of the two ways as follows:</p> <p>a) A bid bond for all parts that bidder participate in the bidding (the value of bid bond will be equal to the total values of the parts that bidder takes part in). Where the value of bid bond submitted by the bidder is less than the total of values, Vietsovpetro is entitled to decide the application of such bid bond to the parts that bidder takes part in;</p> <p>b) Separated bid bonds for each part that bidder takes part in the bidding.</p> <p>Where the bidder's breach results in a failure to refund the bid bond as stipulated in section ITB 18.5, the failure to refund the value of bid bond shall be calculated on the part violated by the bidder.</p>
<p><b>19. Deadline for bid submission</b></p>	<p>19.1. The deadline for bid submission is the time specified in the <b>BDS</b>.</p> <p>19.2. Vietsovpetro may at its discretion, extend the deadline for the submission of Bid Proposal by amending the Invitation to Bid in accordance with ITB 8, in which case all rights and obligations of Vietsovpetro and bidders previously subject to the deadline shall thereafter be subject to the new deadline as extended.</p>

	<p>19.3. The bidder submits directly or delivers the Bid Proposal to Vietsovpetro address provided that it arrives before deadline for submission of bid specified in the <b>BDS</b>. Vietsovpetro receive Bid Proposal of all bidders before deadline for submission of bid, including even if bidder has not bought or received the Invitation to Bid from Vietsovpetro. In such case, the bidder shall pay an amount equal to the selling price of the Invitation to Bid to Vietsovpetro account prior to the Bid Proposal is received and before the deadline for bid submission.</p>
<p><b>20. Submission, withdrawal, substitution and amendment of Bid Proposal</b></p>	<p>20.1. The bidder shall prepare Bid Proposal comprising: one original as specified in ITB 10 and some copies with amount mentioned in the <b>BDS</b>. The cover of dossier shall be marked clearly “ORIGINAL OF BID PROPOSAL”, “COPY OF BID PROPOSAL”.</p> <p>In case of amendment, alternative of Bid Proposal, the bidder shall prepare one original and some copies of dossier with amount specified in the <b>BDS</b>. The cover of dossier shall be marked clearly “ORIGINAL OF AMENDED BID PROPOSAL”, “COPY OF AMENDED BID PROPOSAL”, “ORIGINAL OF ALTERNATIVE”, “COPY OF ALTERNATIVE”.</p> <p>In case of technical alternative in the Bid Proposal specified in ITB 12, the bidder shall prepare one original and some copies with amount mentioned in <b>BDS</b>. The cover of dossier shall be marked clearly “ORIGINAL OF TECHNICAL ALTERNATIVE”, “COPY OF TECHNICAL ALTERNATIVE OPTION”.</p> <p>20.2. Bidders shall be responsible for the appropriateness of the copies compared to the original. In case of deviation between original and copy but without changing the bidder ranking, the original shall be used for evaluation. In case of deviation between original and copy leading to different results in evaluation of original and the copy, and resulting change in the bidder ranking, the Bid Proposal of that bidder shall be rejected.</p> <p>20.3. The original of Bid Proposal shall be typed, printed with inerasable ink, with continuous page numbers. The application for bidding form letter, letter of discount (if any), supplementary documents, clarifying the Bid Proposal, price offer list and other forms in Chapter IV – Bidding forms shall be signed and stamped by the bidder's legitimate representative or the bidder's legitimate attorney (if any), in case of attorney, letter of attorney specified in <a href="#">Form 02</a>, Chapter IV – Bidding forms or certified copy of company charter, decision on establishment of branch or other documents to demonstrate power of attorney shall be submitted with the Bid Proposal.</p> <p>20.4. In case of Consortium bidders, Bid Proposal shall be signed by legal representative of all partners in Consortium or legal partner representing Consortium bidders according to Consortium agreement. In order that all partners of Consortium to be legally bound, Consortium agreement must be signed by legal representatives of all partners of Consortium.</p> <p>20.5. Any words added, written between lines, erased, overwritten shall only be deemed legitimate if having signature nearby or in that page of signatory on the application for bidding letter.</p>

20.6. The envelope of Bid Proposal comprises of original and copies, duly marking “BID PROPOSAL”.

In case of amendment, alternative of Bid Proposal, then the amended, alternative document (including original and copies) shall be placed in separated envelopes other than the envelope for Bid Proposal, clearly marking “AMENDMENT OF BID PROPOSAL”, “ALTERNATIVE BID PROPOSAL”.

In case the bidder proposes an alternative technical plan, the entire alternative technical plan, including technical proposals and price proposals, must be contained in separate envelopes from the Bid Proposal envelop, the outside must clearly state "PROPOSED ALTERNATIVE TECHNICAL OPTION".

The envelopes: for Bid Proposal; amended Bid Proposal, proposed alternative technical options (if any) must be sealed. Sealing method is according to the bidders' own regulations.

20.7. The envelopes shall:

- a) bear the name and address of the bidder;
- b) be addressed to Vietsovpetro in accordance with **BDS**;
- c) bear title of bidding package in accordance with ITB 1.2;
- d) bear a warning “not to open before the time and date for bid opening”.

20.8. The bidder shall be responsible for aftermath or disadvantages if is not in accordance with this Invitation to Bid such as not sealing or losing seal of Bid Proposal during delivery to Vietsovpetro, not marking right information on envelopes of Bid Proposal as specified in ITB 20.6 and ITB 20.7. Vietsovpetro shall not be responsible for confidentiality of information in Bid Proposal if the bidders do not comply with above requirements.

20.9. Vietsovpetro shall not consider any Bid Proposals submitted after the Deadline for bid submission. Any Bid Proposals received by Vietsovpetro after the Deadline for bid submission shall be declared late submission, be rejected and be returned unopened to the Bidder.

20.10. After submitting the Bid Proposals, the Bidders may amend, replace or withdraw the Bid Proposals by sending a written notice signed by the bidder's legal representative, in case of attorney, a power of attorney letter must be enclosed as prescribed in ITB 20.3. Dossier for amendment or replacement of Bid Proposal must be enclosed with a written notification of the corresponding amendment, replacement and must ensure the following conditions:

- a) Being prepared by the Bidders and being submitted to the Vietsovpetro in accordance with ITB 20, the dossier containing the notification must be clearly stated "AMENDMENT OF BID PROPOSAL" or "SUBSTITUTION OF BID PROPOSAL" or "WITHDRAWAL OF BID PROPOSAL ";
- b) Being received by Vietsovpetro before the Deadline for bid submission as stipulated in ITB 19.

20.11. The Bid Proposals which the bidder requests to withdraw in accordance with ITB 20.10 shall be returned unopened to the bidder.

	<p>20.12. The Bidder is not allowed to modify, replace or withdraw the Bid Proposal after the Deadline for bid submission until the expiration of the Bid Proposal's validity as stated in the application for bidding form letter or until the expiration of the extended validity of the Bid Proposal.</p>
<p><b>21. Bid opening</b></p>	<p>21.1. Except in the cases specified in ITB 20, Vietsovpetro shall publicly open and read out, clearly information in accordance with ITB 21.3 of all Bid Proposal received before the deadline for submission of bids. The bid opening shall take place publicly at time and place specified in the <b>BDS</b> in the presence of bidders and representatives of related organizations. The bid opening does not depend on presence or absence of bidders' representatives attending the bid.</p> <p>21.2. In case bidder requests withdrawal or substitution of Bid Proposal, Vietsovpetro shall firstly open and read out clearly information in envelope of which outer notification marks "WITHDRAWAL OF BID PROPOSAL", the envelope of Bid Proposal of bidder with request for withdrawal shall remain sealed and be returned unopened to Bidder. Vietsovpetro shall not accept the Bidders' withdrawal of the Bid Proposal and still open such the Bid Proposal if the written notice of "Withdrawal of Bid Proposal" does not include documents providing that the person signing such documents is the bidder's legal representative and must be publicly announced during the bid opening.</p> <p>Next, Vietsovpetro shall open, read out clearly information in envelope of which outer notification marks "SUBSTITUTION OF BID PROPOSAL" and this shall be replaced with the previous. This previous shall not be opened and be returned unopened to bidder. Vietsovpetro shall not accept the bidder to replace the Bid Proposal if the written notice of Bid Proposal replacement is not accompanied by documents proving that the person signing the document is the bidder's legal representative and must be made public during the bid opening.</p> <p>For envelope with notification marked "SUBSTITUTION OF BID PROPOSAL", any attached notification document accompanied with amended Bid Proposal shall be opened, read out clearly. Vietsovpetro shall not accept the bidder to amend the Bid Proposal if the written notice of Bid Proposal's amendment does not include documents proving that the person signing the document is the bidder's legal representative. Only Bid Proposal opened and read out at the bid opening then shall be considered further and evaluated.</p> <p>21.3. All the Bid Proposals shall be opened one at a time following the alphabetical sequence of the bidders' names and sequence below:</p> <ol style="list-style-type: none"> <li>a) Examine the seals;</li> <li>b) Open original of Bid Proposal, amendment of Bid Proposal (if any) and read out clearly at least the following information: name of bidder, quantity of originals and copies, bidding price in letter of bid, bidding price in summarized price list, discount (if any), validity of Bid Proposal, date of contract performance, value, validity of Bid Bond and other necessary information. In case bidding package is divided into many independent parts, then</li> </ol>

	<p>bidding prices and discount for each part shall be read out. Only discount read out in bid opening shall be further considered and evaluated;</p> <p>c) Representatives of Vietsovpetro shall countersign in original of letter of bid, Bid Bond, summarized price list, letter of attorney of bidder's legal representative (if any), letter of discount (if any), Consortium agreement (if any). Vietsovpetro shall not reject any Bid Proposal at the bid opening, except for late submission Bid Proposals as specified in ITB 20.</p> <p>21.4. Vietsovpetro shall prepare a record of the bid opening that shall include information specified in ITB 21.3. The record shall be signed by representatives of Vietsovpetro and bidders attending bid opening. The omission of a bidder's signature on the record shall not invalidate the contents and effect of the record. The record shall be distributed to all bidders attending the bid.</p>
<b>22. Confidentiality</b>	<p>22.1. Information relating to the evaluation of bids and recommendation of contract award shall not be disclosed to bidders or any other persons not officially concerned with the bidder selection process until publication of result of bidder selection. Under no circumstances, is the information in Bid Proposal revealed to any other bidders, except for the information that need disclosing during the bid opening.</p> <p>22.2. Except for the case of enquiries for clarification of Bid Proposal and comparing documents, bidder is not allowed to contact with Vietsovpetro for issues related to bidder's Bid Proposal and other relevant issues of bidding package during the time from bid opening until the result of tendered selection is published.</p>
<b>23. Clarification of Bid Proposal</b>	<p>23.1. After bid opening, the bidder shall be responsible to clarify the Bid Proposal if required by Vietsovpetro, including eligibility, capacity and experiences of the Bidder. In terms of technical, financial proposal in bidder's Bid Proposal, the clarification shall comply with the principle of not changing the basic content of the submitted Bid Proposal and not changing the offered bidding price.</p> <p>23.2. During the evaluation process, clarification of Bid proposal between Bidders and Vietsovpetro is performed directly in written.</p> <p>23.3. Clarification of Bid Proposals is only performed between the Vietsovpetro and Bidder whose Bid Proposals need to be clarified. In terms of clarification contents that directly affect evaluation of eligibility, capacity, experiences, technical requirement, financial issues, if period of clarification exceeds deadline and bidder does not submit documentation for clarification or submitted documentation does not comply with requirements of clarification from Vietsovpetro, Vietsovpetro shall evaluate based on the Bid Proposal submitted before deadline for bid submission. Vietsovpetro shall give the Bidder a reasonable period of time to clarify the Bid Proposal.</p> <p>23.4. <b>In case after Deadline for submission of bids, the bidder knowing that the Bid Proposal it has submitted falls short of documents establishing its eligibility, similar contracts, production capacity, financial reports, tax declaration and payment obligations, documents on personnel, specific equipment proposed in its Bid Proposal may provide such evidence to the Procuring</b></p>

	<p>entity within a period of time specified in the BDS. The Procuring entity shall receive, consider and evaluate the bidder's additional and clarifying documents, which shall be considered as part of the Bid Proposal.</p> <p>23.5. In case of any inconsistencies in the Bid Proposal's content or on the condition that the content is unclear, Vietsovpetro request clarification toward the bidder based on compliance as specified in ITB 23.1.</p> <p>23.6. In case of doubt about the authenticity of documents provided by the Bidder, Vietsovpetro shall verify with organizations and individuals related to the content of the documents.</p> <p>23.7. In case the Invitation to Bid requires the commitment, Contract Principles for equipment rental, main material supply, warranty, upkeep and maintenance, but such documents are not enclosed in the Bid Proposals, Vietsovpetro shall request Bidders to clarify their Bid Proposals and supplement documents within an appropriate period of time but not less than 03 working days as a basis for evaluation of Bid Proposals.</p>
<p><b>24. Deviations, imposing conditions and omissions</b></p>	<p>During the evaluation of bid proposal, the following definitions apply:</p> <p>24.1. "Deviation" is a difference from the requirements specified in the Invitation to Bid;</p> <p>24.2. "Imposing Conditions" is the setting of limiting conditions or withholding from complete acceptance of the requirements specified in the Invitation to Bid;</p> <p>24.3. "Omission" is the Bidder's failure to submit part or all of the information or documentation required in the Invitation to Bid.</p>
<p><b>25. Determination of responsiveness</b></p>	<p>25.1. Vietsovpetro's determination of a responsiveness of Bid Proposal is to be based on the contents of the Bid Proposal itself, as defined in ITB 10.</p> <p>25.2. A substantially responsive Bid Proposal is one that meets the requirements of the Invitation to Bid without material deviations, conditions, or omissions. A material deviation, reservation, or omission is one that:</p> <p>a) If accepted, would affect in any substantial way the scope, quality, or performance of the goods and related services; limit in any substantial way, inconsistent with the Invitation to Bid, Vietsovpetro's rights or the bidder's obligations under the contract;</p> <p>b) If rectified, would unfairly affect the competitive position of other bidders presenting substantially responsive Bid proposal that meet the requirement of the Invitation to Bid.</p> <p>25.3. Vietsovpetro shall examine the technical aspects of the Bid Proposal submitted in accordance with ITB 15 and ITB 16, in particular, to confirm that all requirements of the Invitation to Bid have been complied without any material deviation or reservation, or omission.</p> <p>25.4. If the Bid Proposal is not substantially responsive to the requirements of Bidding Document, it shall be rejected; not being allowed to deviations, reservation conditions or omission of basic content in such Bid Proposal with the purpose of making Bid Proposal to be met substantially responsive to the requirements of Bidding Document.</p>

<p><b>26. Nonmaterial mistake</b></p>	<p>26.1. Provided that a Bid Proposal is substantially responsive, Vietsovpetro may waive any mistakes in the bid proposal that not to be a material deviation, reservation or omission.</p> <p>26.2. Provided that a bid proposal is substantially responsive, Vietsovpetro may request that the bidder submits the necessary information or documentation, within a reasonable period of time, to rectify inappropriate points or nonmaterial mistake in the bid related to documentation requirements. The request for provision of information and documentation to rectify such mistakes shall not be related to any aspect of the bidding price. Failure of the bidder to comply with the request may result in the rejection of its Bid Proposal.</p> <p>26.3. Provided that a bid proposal is substantially responsive, Vietsovpetro shall rectify quantifiable nonmaterial mistakes related to the bidding price; the bidding price shall be adjusted to reflect the price of a missing or non-conforming item or component; this adjustment is for comparison purposes only.</p>
<p><b>27. Sub-contractor</b></p>	<p>27.1. Sub-contractors are organizations, individuals signing contracts with the bidders to perform related services.</p> <p>27.2. Requirements of Subcontractors are specified in <b>BDS</b>.</p> <p>27.3. Sub-contracting will not change the bidder's responsibilities. The bidders shall be responsible for the workload, quality, progress and other responsibilities for the parts of the contract carried out by the subcontractors. Sub-contractors' capacity and experiences shall not be considered in evaluation of the Bidder's Bid proposal. The bidder itself must comply with capacity criteria (no consideration of sub-contractors' capacity and experiences).</p> <p>27.4. The bidder may sign contracts with sub-contractors according to the list of sub-contractors stated in the Bid Proposal or signing contracts with sub-contractors approved by Vietsovpetro to participate in performing the work.</p> <p>27.5. The bidders is not allowed to utilize the sub-contractors to carry out the tasks other than the tasks of the subcontractors mentioned in the Bid Proposal; the replacement or addition of sub-contractors other than the list of sub-contractors prescribed in the Bid Proposal shall only be carried out when there is a valid and appropriate reason and is approved by Vietsovpetro; in case sub-contractors are utilized to carry out the taks other than the tasks listed in the Bid Proposal that using a sub-contractor with a value of 10% or higher (after deducting the work part of the sub-contractor's responsibility) calculated on the contract price signed, as an act of "bid transfer".</p>
<p><b>28. Bid preferences in the selection of bidder</b></p>	<p>28.1. Rules of bid preferences: Bidders shall be granted preferential treatment when supplying goods of which costs for domestic production occupy 25% or higher.</p> <p>28.2. Bid preferences are applied during evaluation process for comparing and rating Bid Proposal: Goods are eligible for bid preferences provided that bidders prove that domestic production costs account for above 25% of total price. Percentage (%) of domestic production cost of goods is calculated according to the following formula:</p>

	<p style="text-align: center;"><b>D (%) = G*/G (%)</b></p> <p>Where:</p> <ul style="list-style-type: none"> <li>- G*: Domestic production cost calculated by quoted price of goods defined in the Bid Proposal which subtracts tax values and external costs, inclusive of fees and charges (if any);</li> <li>- G: Quoted price of goods defined in the Bid Proposal subtracting tax values;</li> <li>- D: Percentage (%) of domestic production cost of goods, D gains the rate of 25%, which can enable goods to receive the bid preferences as regulated in this clause.</li> </ul> <p>28.3. Bid preferences calculation is specified in the <b>BDS</b>.</p> <p>28.4. Bidder must declare information about the eligible types of goods for bid preferences according to Forms 15A, 15B and 15C Chapter IV that is on the basis of consideration and evaluation of bid preferences. In case bidders does not declare so, the Bidder's goods are considered not eligible for bid preferences.</p> <p>28.5. In case goods do not receive bid preferences, evaluation and determination of bid preferences shall not be applied.</p> <p>28.6. In case of bidders ranking equally, priority shall be given to those with:</p> <ul style="list-style-type: none"> <li>- Goods originating from the Socialist Republic of Vietnam and the Russia Federation.</li> <li>- Services/Jobs that employ workers from the Socialist Republic of Vietnam and the Russian Federation.</li> </ul>
<p><b>29. Bid Proposal evaluation</b></p>	<p>29.1. Vietsovpetro shall apply evaluation criteria listed in this clause and methods of evaluation are specified in the <b>BDS</b>. Any other criteria and methods of evaluation shall not be allowed.</p> <p>29.2. Vietsovpetro shall evaluate directly on the bid proposals submitted by the bidder.</p> <p>29.3. Verify and evaluate eligibility of Bid Proposal:</p> <ul style="list-style-type: none"> <li>a) The verification and evaluation of eligibility of Bid Proposal as specified in clause 1, Chapter III – Bid Proposal Evaluation criteria;</li> <li>b) Any bidders who have eligibility Bid Proposal shall be further considered and evaluated with respect to capacity and experiences.</li> </ul> <p>29.4. Evaluation of capacity and experiences:</p> <ul style="list-style-type: none"> <li>a) Capacity and experiences are evaluated as specified in clause 2, Chapter III – Bid Proposal Evaluation criteria;</li> <li>b) Bidders with satisfactory capacity and experiences shall be considered and evaluated to examine their technical capability.</li> </ul> <p>29.5. Technical and price-based evaluation:</p> <ul style="list-style-type: none"> <li>a) Evaluation of technical capability must adhere to the evaluation standards and methods prescribed in Section 3, Chapter III – Bid Proposal Evaluation criteria;</li> <li>b) Bidders who satisfy technical requirements shall be considered to evaluate the price specified in Section 4, Chapter III – Bid Proposal Evaluation criteria.</li> </ul> <p>29.6. After price-based evaluation, Vietsovpetro shall make and approve ranking list of bidders. The bidder ranked at the first position in the bidder's ranking list shall be eligible for the contract</p>

negotiation. Ranking of bidders shall be made as prescribed in the **BDS**.

29.7. In case the Invitation to Bid is divided into independent parts and bidder is allowed bidding in each part prescribed in ITB 1.2, bid evaluation is carried out with those respective parts of the bidder as prescribed in Section 6, Chapter III – Bid Proposal Evaluation criteria.

29.8. Principle of Bid proposal's evaluation:

a) Vietsovpetro evaluate directly based on the bid proposals submitted by the bidder. In case the information committed, declared in the Bid proposal is not truthful, leading to false results of evaluating Bid proposal of the bidder, bidder shall be considered to have committed fraudulent;

b) In case there is inconsistency between information of similar contract and supporting documents proving information of such similar contract, Vietsovpetro request bidder to clarify the Bid proposal. In case the contracts declared, enclosed in the Bid proposal that not meeting the requirements of Invitation to Bid or the Bidder does not declare or incompletely declares the similar contracts, Vietsovpetro request the bidder to clarify and supplement the another contract to meet the requirements of the Invitation to Bid within an appropriate period of time but not less than 03 working days. In case the bidder does not have a contract met the requirements of the Invitation to Bid, the bidder shall be disqualified;

c) In case the key personnel and key equipment (if any) proposed by the contractor in the Bid proposal not meeting the requirements, Vietsovpetro allow the bidder to supplement or replace. Bidders are only allowed to add or replace each personnel position, equipment once within an appropriate period of time but not less than 03 working days. In case the Bidder does not have the replacement of personnel and equipment that meet the requirements of the Invitation to Bid, the bidder will be disqualified. Under any circumstances, on condition that the Bidder dishonestly declares personnel and equipment, the Bidder is not allowed to substitute other personnel or equipment, the Bidder's Bid proposal shall be rejected and the Bidder shall be considered having committed fraudulent according to regulations with legislation on bidding or other relevant legislation and shall be subject to be handled according to regulations;

d) For the origin of the goods, in case there is any inconsistency between the declared information and attached documents, Vietsovpetro request clarification of the Bid proposal;

e) For contents other than those mentioned in Points a, b, c and d of this Clause, in case there is inconsistency between the information in the original Bid proposal and the copy of the Bid proposal, the information in the original Bid proposal is the basis for review and evaluation;

f) At the financial assessment step, in case the Bidder does not declare information in the bid preferences's form for domestically produced goods (for Goods procurement bidding packages) in order that Vietsovpetro have a basis for calculating bid preferences, then Bidder will not receive the bid preferences.

<p><b>30. Contract negotiation</b></p>	<p>Contract negotiation shall be stipulated in <b>BDS</b>.</p> <p>30.1. Contract negotiation shall be based on the followings:</p> <ul style="list-style-type: none"> <li>a) Report on evaluation of the Bid Proposal;</li> <li>b) Bid Proposal and bidder’s records of clarification of bidding package (if any);</li> <li>c) Invitation to Bid.</li> </ul> <p>30.2. Principles of the contract negotiation:</p> <ul style="list-style-type: none"> <li>a) Not negotiating on the contents the bidder offered in accordance with the requirements of the Invitation to Bid;</li> <li>b) While evaluating Bid Proposal and negotiating contract, if realizing the scope of supply/ work, workloads specified in Chapter V – Scope of Supply are insufficient compared with the design documentation, Vietsovpetro shall request bidder to add supplement scope for this insufficient part, on the basis of the quoted price; if the Bid Proposal has not provided the unit price, Vietsovpetro shall consider and decide on applying the unit price approved estimated price for these scope of work/ inadequate workloads compared to the design documentation or the unit price quoted by other bidders who have passed the technical evaluation if this unit price is lower than the approved unit price in the estimated bidding package;</li> <li>c) When negotiating a contract for the deficient deviation, if the Bidder's bid proposal does not have a unit price corresponding to the deviation, the lowest bid unit price among other bidders' bid proposals that meet the technical requirements must be taken or taking the unit price in the approved estimate if this is the only bidder who passes the technical evaluation step as a basis for negotiating that deficient deviation.</li> </ul> <p>30.3. Contents of contract negotiation:</p> <ul style="list-style-type: none"> <li>a) Unspecified, inappropriate and inconsistent contents between Invitation to Bid and Bid Proposal, between different contents in the Invitation to Bid may lead to incidents, disputes or impact on the contractual obligations of contracting parties;</li> <li>b) Deviations that have been found by the Bidder and Bidder’s recommendations (if any), including proposal of amendment or technical alternatives which Bidder is allowed to provide according to relevant bidding regulations;</li> <li>c) Any issue that arises during the selection of Bidder (if any) in the aim of completing detailed contents of the bidding package;</li> <li>d) Nonmaterial omissions specified in ITB 30;</li> <li>e) Other necessary issues.</li> </ul> <p>30.4. During contract negotiation, negotiating parties must proceed to draft and complete the official agreement, detailed terms and conditions and annexes that determine detailed list of scope of supply, price list and progress of supply.</p> <p>30.5. If the negotiation fails, Vietsovpetro shall consider, decide to invite the bidder who is ranked at the next positions for contract negotiation; if the successive negotiations also fail, Vietsovpetro shall report to the Investor to consider, decide the bidding cancellation as regulated in point a, ITB 32.1.</p>
----------------------------------------	------------------------------------------------------------------------------------------------------------------------------------------------------------------------------------------------------------------------------------------------------------------------------------------------------------------------------------------------------------------------------------------------------------------------------------------------------------------------------------------------------------------------------------------------------------------------------------------------------------------------------------------------------------------------------------------------------------------------------------------------------------------------------------------------------------------------------------------------------------------------------------------------------------------------------------------------------------------------------------------------------------------------------------------------------------------------------------------------------------------------------------------------------------------------------------------------------------------------------------------------------------------------------------------------------------------------------------------------------------------------------------------------------------------------------------------------------------------------------------------------------------------------------------------------------------------------------------------------------------------------------------------------------------------------------------------------------------------------------------------------------------------------------------------------------------------------------------------------------------------------------------------------------------------------------------------------------------------------------------------------------------------------------------------------------------------------------------------------------------------------------------------------------------------------------------------------------------------------------------------------------------------------------------------------------------------------------------------------------------------------------------------------------------------------------------------------------------------------------------------------------------------------------------------------------------------------------------------------------------------------------------------------------------------------------------------------------------------------------------------------------------------------------------------------------------------------------------------------------------------------------------------------------------------------------------------------------------------------------------------------------------------------------------------------------------------------------------------------------------------------------------------------------------------------------------------------------------------------------------------------------

<p><b>31. Conditions for recommendation as the awarded bidder</b></p>	<p>Bidder shall be considered for recommendation as the winning bidder upon satisfying the following conditions:</p> <p>31.1. Having Eligibility Bid Proposal as prescribed in Section 1, Chapter III;</p> <p>31.2. Having capacity and experiences satisfying requirements as prescribed in Section 2, Chapter III;</p> <p>31.3. Having technical proposals satisfying requirements as prescribed in Section 3, Chapter III;</p> <p>31.4. Having deficient deviation not exceeding 10% of bidding price;</p> <p>31.5. Meeting requirements specified in the <b>BDS</b>;</p> <p>31.6. The bidder has the proposed price award (including taxes, fees, charges (if any) not exceeding the approved bidding package price. If the approved estimated budget of bidding package is lower than or higher than the approved bidding package price, this estimate shall replace the bidding package price as basis for consideration for recommendation as the winning bidder.</p>
<p><b>32. Bidding cancellation</b></p>	<p>32.1. Vietsovpetro shall notify the bidding cancellation in following cases:</p> <p>a) All Bid Proposals fail to satisfy the requirements of the Invitation to Bid;</p> <p>b) Change of the objectives, scope of procurement resulting in changes in volume of work and evaluation criteria stated in the Invitation to Bid at Vietsovpetro's decision;</p> <p>c) The Invitation to Bid fails to comply with legislation on bidding or other relevant legislation that lead to the failure of the selected bidder to meet requirements for performing bidding package;</p> <p>d) The award bidder commits prohibited acts specified in section 4 prohibited acts - Chapter I Instructions to Bidders;</p> <p>e) Organizations and individuals other than the awarded bidder commit prohibited acts specified in section 4 prohibited acts - Chapter I Instructions to Bidders leading to deviations in bidder selection results.</p> <p>32.2. Organizations and individuals infringing law on bidding that lead to bidding cancellation as prescribed in point c, d, e in ITB 32.1 is undertaken to compensate expenses for related parties and be handled as prescribed by law.</p> <p>32.3. In case of bidding cancellation specified in this section, Vietsovpetro shall return or release Bid Bond to bidders who has submitted the original Bid Bond within 05 working days, except the bidder violates the regulation as specified in point d and point e, ITB 32.1.</p>
<p><b>33. Notice of bidder selection result</b></p>	<p>33.1. Vietsovpetro shall publish notice of bidder selection results within 05 working days from the date of approval of bidder selection results. Notice of bidder selection result shall include following contents:</p> <p>a) Information of the bidding package:</p> <ul style="list-style-type: none"> <li>- Number of Invitation to Bidder;</li> <li>- Name of the bidding package;</li> <li>- Bidding package price or approved estimate (if any);</li> </ul>

	<ul style="list-style-type: none"> <li>- Name of Investor;</li> <li>- Form of bidder selection;</li> <li>- Type of contract;</li> <li>- Time to implement the bidding package;</li> <li>- Time of contract performance.</li> </ul> <p>b) Information of the awarded bidder:</p> <ul style="list-style-type: none"> <li>- Tax code;</li> <li>- Contractor name;</li> <li>- Bidding price;</li> <li>- Bidding price after discount (if any);</li> <li>- Technical scores (if any);</li> <li>- Evaluation price (if any);</li> <li>- Awarded bidding price;</li> <li>- Time to implement the bidding package.</li> </ul> <p>c) For each type of goods and equipment in the bidding package, the Investor must publish the following information:</p> <ul style="list-style-type: none"> <li>- Goods name;</li> <li>- Wattage;</li> <li>- Features and technical specifications; models, part numbers, labels;</li> <li>- Origin;</li> <li>- Awarded of bidding unit price.</li> </ul> <p>d) List of unselected bidders and brief reasons of each bidder for not being selected.</p> <p>33.2. In case of bidding cancellation as prescribed in point a, ITB 32.1, in the notice of bidder selection results and on the national bidding network must be clearly stated the reason for cancellation of bidding.</p>
<p><b>34. Change in volume of goods and services</b></p>	<p>34.1. At the time of awarding contract, Vietsovetro are entitled to increase or decrease the volume of services stated in Chapter IV provided that such change not exceeding the rate specified in the <b>BDS</b> and there is not any change in the unit price or other terms and conditions of the Bid Proposals and Invitation to Bid. The rate of increase and decrease in volume shall not exceed 10%.</p> <p>34.2. Additional purchase option: Before the contract expires, the Investor has the right to purchase an additional volume of goods or services in the bidding package other than the volume stated in Chapter IV provided that not exceeding the rate specified in the <b>BDS</b>.</p>
<p><b>35. Notice of Bid Proposal acceptance and contract award</b></p>	<p>After publishing the notice of bidder selection results, Vietsovetro send a notice of acceptance of the Bid proposals and award the contract, including requirements on measures of contract performance guarantee, completion time, and contract signing. VND according to the provisions in Form as prescribed in Part 4 for the awarded bidder. Notice of acceptance of bid proposals and contract award are part of the contract documentation. In case the awarded bidder fails to complete, sign the contract or submit the contract performance guarantee within the deadline stated in the notice of bid proposal's acceptance and contract award, the bidder</p>

	shall be disqualified and shall not be refunded the value of Bid bond as prescribed in Section 18.5 ITB. The period of time stated in the notice of bid proposal acceptance is calculated from the date Vietsovpetro sending this acceptance notice to the awarded bidder on the nation bidding network.
<b>36. Conditions for signing contract</b>	<p>36.1. At time of signing contract, Bid Proposal of the selected bidder are still valid.</p> <p>36.2. At time of signing contract, the selected bidder must ensure to meet requirements on technical and financial capability for implementation as prescribed in the Invitation to Bid. If the bidder no longer meets basic requirements of technical and financial capability prescribed in the Invitation to Bid, Vietsovpetro shall refuse to sign contract with the bidder. Vietsovpetro shall therefore cancel previous decision on approval of bidder selection result and contract award, and shall invite the bidder who is ranked at the next position for comparing documentation and contract negotiation (if required).</p> <p>36.3. Vietsovpetro shall ensure conditions on funding for advance payment, payment funding and other necessary conditions for carrying out the bidding package on the schedule.</p>
<b>37. Contract performance guarantee</b>	<p>37.1. Before signing a contract or before the contract comes into effect, the bidder shall provide contract performance guarantee as specified in Part 3. In case of applying a form of contract performance guarantee, the form specified in Part 3 or another form approved by Vietsovpetro shall be complied.</p> <p>37.2. The bidder shall not be entitled for the returning of the contract performance guarantee in the following cases:</p> <ul style="list-style-type: none"> <li>a) The bidder refuses to perform the contract after the date the contract comes into force;</li> <li>b) The bidder violates agreements in contract;</li> <li>c) Performing the contract behind schedule due to bidder's fault but refusing to extend the validity of the contract performance guarantee.</li> </ul>
<b>38. Handling of complaints in bidding</b>	<p>38.1. When bidder's legal rights and interests are affected, the bidders, agencies and organizations may file any complaint to Vietsovpetro with respect to procurement process, bidder selection result according to the regulations of Vietsovpetro.</p> <p>38.2. In case of petition to Vietsovpetro, the bidder shall send the petition to the address specified in the <b>BDS</b>.</p>
<b>39. Monitoring, supervising of Bidder selection process</b>	When detecting violated behavior or content inconsistent with the provisions of bidding law, the bidder is responsible for notifying the organization, individual performing the monitoring task and supervision as prescribed in the <b>BDS</b> .

## Chapter II. BIDDING DATA SHEET

<b>ITB 1.1</b>	Name of Employer: Vietsovpetro
<b>ITB 1.2</b>	<p><b>Title of bidding package: Air winch 5 ton for Tam Dao 02 - Block 09-1 (Bidding package No. VT-3657/25-KB)</b></p> <p><b>Name of project: Air winch 5 ton for Tam Dao 02 - Block 09-1 (Bidding package No. VT-3657/25-KB)</b></p> <p>Quantity of parts in bidding package: (See Attachment 01 of Part 4)</p> <p>Vietsovpetro will evaluate and select for the whole package</p> <p>Year of production: See technical requirements attached</p> <p>Scope of supply: See Attachment 01 of Part 4 (01 page)</p> <p>Technical requirement: See Attachment 02 of Part 4 (02 pages)</p> <p>Technical evaluation criteria: See Attachment 03 of Part 4 (03 pages)</p>
<b>ITB 3</b>	The source of funding: Block 09-1
<b>ITB 5 (d)</b>	<p>Competitiveness in the bidding must be ensured by following rules:</p> <ul style="list-style-type: none"> <li>- Bidders participating in bidding do not have a shareholding or equity contribution representing more than 30% with Vietsovpetro, except in the case of: <ul style="list-style-type: none"> <li>(i) The bidder is an affiliate or subsidiary of a state-owned corporation or group whose main production and business lines are consistent with the nature of the bid package of that state-owned corporation or group.</li> <li>(ii) The bidder is a parent company, subsidiary, or affiliate of a state-owned corporation or group whose main production and business lines are suitable for products and services under the bid package, and this bid package belongs to its subsidiary or affiliate.</li> </ul> </li> <li>- The bidder do not either have a shareholding or equity contribution relationship with consultants or have a shareholding or equity contribution representing more than 20% of equity owned by a third party being an entity or a natural person, specifically as follows: <ul style="list-style-type: none"> <li>+ Consulting on preparation for technical design: <i>Not applicable</i>;</li> <li>+ Consulting on verification of bid price: <i>Not applicable</i>;</li> <li>+ Consulting on supervision of contract execution and inspection: <i>Not applicable</i>;</li> <li>+ Consulting on preparation for the ITB: <i>Not applicable</i>;</li> <li>+ Consulting on appraisal of the ITB: <i>Not applicable</i>;</li> <li>+ Consulting on evaluation Bid Proposal: <i>Not applicable</i>;</li> <li>+ Consulting on appraisal of bidder selection results: <i>Not applicable</i>;</li> <li>+ Project management consulting, contract management, other consulting services whose work is directly related to the bid package: <i>Not applicable</i>;</li> </ul> </li> <li>- The bidder does not belong to the same agency or organization directly managing the consultants (mentioned above)<sup>1</sup>.</li> </ul>

<sup>1</sup> Only evaluate this content for bidders that are public sector entities.

	<p>- Public sector entities and employers, procuring entities that have the same direct governing authority, and equity contribution when participating in bidding for each other's bid packages shall not have to satisfy the regulations on legal and financial independence between the bidder and the employer and the procuring entity.</p> <p>- Public sector entities and enterprises that have the same direct governing authority, and equity contribution when participating in bidding for each other's bid packages shall not have to satisfy the regulations on legal and financial independence between the bidder and the employer and the procuring entity.</p> <p>- The ratio of shares, equity contributions between the parties is determined at the deadline for submission of bids and according to the ratio stated in the business registration certificate, establishment decision, and other documents of equivalent value.</p> <p>In case the bidder participates in the bidding as a joint venture or the consultant is selected as a joint venture, the equity ownership ratio of other organizations and individuals in the joint venture is determined according to the following formula:</p> $\text{Ownership ratio} = \sum_{i=1}^n X_i \times Y_i$ <p>Of which:</p> <p>X<sub>i</sub>: Equity ownership ratio of other organizations and individuals in the i-th joint venture member;</p> <p>Y<sub>i</sub>: Percentage (%) of the work volume of the i-th joint venture member in the joint venture agreement;</p> <p>n: Number of members participating in the joint venture.</p>
<b>ITB 5 (h)</b>	<p>Bidder's name is registered on National bidding network before the grant of approval for contractor selection result as prescribed:</p> <p>- Bidders have to register procurement information on <b>the National bidding network: <u>To be applied</u></b></p> <p>- Bidders are to provide confirmation of information registration on the national bidding network system in according to the Circular issued by Ministry of Planning &amp; Investment for providing provisions on posting information about bidding, on the roadmap for applying online Contractor selection, and managing the use of the value of bidding guarantee, ensuring the performance of non-refundable contracts:</p> <p><u>Detailed instructions of the National bidding network system are on the website: <a href="http://muasamcong.mpi.gov.vn">http://muasamcong.mpi.gov.vn</a></u></p>
<b>ITB 7.1</b>	<p>The amendment of Invitation to Bid shall be published in National bidding network at least <b>03 working days</b> prior to the Deadline for bid submission.</p>
<b>ITB 7.2</b>	<p>Requests for clarification should be received by Vietsovetro at least <b>05 working days</b> prior to the Deadline for bid submissions.</p> <p>Vietsovetro shall clarify the request of clarification at least <b>03 working days</b> prior to Deadline for bid submissions.</p>
<b>ITB 7.3</b>	<p>Pre-bidding conference: No</p>
<b>ITB 8</b>	<p>Payment for the Invitation to Bid:</p>

	<p>Interested bidders can buy Invitation to Bid with non-refundable cost of VND 500,000.00/set (in word: Five hundred thousand Vietnam Dong/set)</p> <p>Payment for Invitation to Bid shall be made by Telegraphic Transfer to the following Vietsovetro's account: Account No. 008.100.000001.1 Beneficiary: Vietsovetro VIETCOMBANK, Vung Tau Branch</p> <p>Please indicate: Bidder name, payment for Invitation to Bid Bidding package <b>No. VT-3657/25-KB</b></p>
<b>ITB 10.10</b>	<p>The Bidder shall submit the following additional documents in its bid proposal:</p> <p>Scope of supply, Scope of work and Technical documentation as required in Technical requirement (Part 2 Chapter V – Scope of supply, Scope of work and Technical documents, etc. in Invitation to Bid)</p>
<b>ITB 12.1</b>	<p><b>Bidder is allowed to submit Technical alternative as required in technical requirements (if any).</b></p> <p>The bidder is required to clearly state the main offer and the alternative offer in the bidding proposal. Technical alternatives are only considered when main solution meets requirements and bidder is ranked first. In this case, bidder shall provide all information necessary for evaluation of the alternatives by Vietsovetro, including notes, drawings, technical specifications, progress of supply and other relevant information</p>
<b>ITB 13.5</b>	<p>In the detailed price quotation table, bidder shall offer prices according to the following requirements:</p> <p><b>For foreign bidders:</b> The Bidders are requested to offer price on delivery term CFR Vietsovetro port, Vung Tau City, S.R. Vietnam in accordance with Incoterms accompanied with appropriate amendments – if necessary as Bidding form No. 12A, Chapter IV – Bidding form and provide “Incoterms 2020”.</p> <p>In case goods are accompanied with services, commissioning, ... Bidders have to clearly state that whether the offered price includes Foreign Contractor Withholding Tax (FCWT) as Bidding form No. 13. If the offered price has not included, Vietsovetro will calculate and add FCWT into the offered price for comparison and evaluation (<i>FCWT tax rate is: 1.01% for goods</i>). Vietsovetro shall do necessary procedures for tax exemption of goods.</p> <p><b>For Vietnamese Bidders:</b> The Bidders are requested to offer price on delivery to Vietsovetro warehouse. Vung Tau City, S.R. Vietnam including all taxes, fees and charges (if any) arisen inside Vietnam and shall be taken into consideration exemption of import tax and VAT for imported goods from using List of exempted goods available for Vietsovetro in Block 09-1 as Bidding forms No. 12A and 12B, Chapter IV – Bidding forms.</p>
<b>ITB 15.6</b>	<p>Expected operating duration of Goods (for the purpose of requirement of spare parts, specialized tools): Not applicable.</p>

<b>ITB 16.2</b>	The documentary evidence of the Bidder's capacity to perform the contract if the bidder win the bid including: Manufacturer's License for sale or the Certificate of Partnership or similar documents: <i>as per Technical requirement, Chapter V in Invitation to Bid.</i>
<b>ITB 17.1</b>	The Bid proposal shall be valid for <b>120 days</b> from the Deadline for bid submission.
<b>ITB 18.1</b>	The Bidder provides the Bid Bond through Deposit / Telegraphic Transfer to the following Vietsovpetro's account: <b>Account: 008.100.000001.1 (VND)</b> <b>0081370000029 (USD)</b> <b>Beneficiary: Vietsovpetro</b> VIETCOMBANK, Vung Tau Branch
<b>ITB 18.2</b>	Contents of Bid Bond: The amount and currency of the Bid Bond shall be: <b>USD 530,00 USD/ 14.045.000 VND</b> The Bid Bond shall be valid for <b>150 days</b> from the Deadline for bid submission. In case the Bidder provides the Bid Bond through Deposit/Telegraphic Transfer to the following Vietsovpetro's account: <b>Account: 008.100.000001.1 (VND)</b> <b>0081370000029 (USD)</b> <b>Beneficiary: Vietsovpetro</b> VIETCOMBANK, Vung Tau Branch
<b>ITB 18.4</b>	The Bid Bond of unsuccessful Bidders shall be returned or released in maximum 14 days from the date of Notification of Bidder selection Result.
<b>ITB 19.1</b>	The <b>Deadline for bid submission</b> at: <b>09h00 (local time) on ____/____/2025</b>
<b>ITB 20.1</b>	In addition to original of Technical Proposal and Financial Proposal, the quantity of copies of Technical Proposal (as per required in Technical requirement), Financial Proposal (01 copy). In case of modification, substitution of Technical Proposal, Financial Proposal or technical alternative, the bidders must submit the equal number of copies of modification, substitution or Technical alternative. <b>Notes:</b> <b>Quantity of Proposal:</b> + <b>Technical Proposal: 01 original and 02 copies;</b> + <b>Financial Proposal: 01 original;</b> + <b>Soft copy:</b> <b>01 USB included scanned Technical Proposal;</b> <b>01 USB Financial Proposal and native excel file of Financial Proposal.</b> + <b>All of the Proposals shall be sealing and marking as requirement in Chapter I Point 21.</b>

<b>ITB 20.7 (a)</b>	Bidders shall submit their Bid Proposals to: Recipients: Vietsovpetro Address: 105 Le Loi Str, Vung Tau ward, HCM City, Vietnam
<b>ITB 21.1</b>	The Bid proposal shall be opened publicly: At the following address: Vietsovpetro, 105 Le Loi Str, Vung Tau ward, HCM City, S.R. Vietnam Time: at <b>09h30 (local time) on _____/_____/2025</b>
<b>ITB 23.4</b>	<b>Bidders themselves can provide such evidence to Vietsovpetro within 03 days from the Deadline for submission of bids.</b>
<b>ITB 27.2</b>	Total value of sub-contractor(s) shall not exceed: <b>0%</b> of total value of Bid proposal. Specialized sub-contractor: Not applicable.
<b>ITB 28.3</b>	Calculation of preferential treatment: Goods that do not receive bid preferences must add a monetary amount accounting for 7.5% of bidding price after rectification of errors, adjustment of deviations and deduction of discounts (if any) of these goods to the bidding price after rectification of errors, adjustment of deviations and deduction of discounts (if any) of bidders for comparison and ranking.
<b>ITB 29.1</b>	Bid proposal evaluation methods: a. Evaluation of the bidder's capacity and experience: using Pass/Fail criteria. b. Technical evaluation: <i>to apply evaluation method using Pass/Fail or Yes/No criteria in accordance with evaluation criteria stipulated in Section III, Chapter III, Bid Proposal Evaluation Criteria.</i> c. The price evaluation: <i>to apply lowest price method <b>for the whole package</b> in accordance with evaluation criteria stipulated in Section V, Chapter III, Bid Proposal Evaluation Criteria.</i>
<b>ITB 29.6</b>	<b>Ranking of bidders: the bidder who has the lowest price <b>for the whole package</b> after rectification of errors, adjustment of deviation and deduction of discounts (if any) is ranked the first.</b>
<b>ITB 30</b>	Contract negotiation: <b>Not applicable.</b>
<b>ITB 31.5</b>	<b>Having lowest bidding price for the whole package after rectification of errors, adjustment of discrepancies, taking into account discount (if any), conversion of bidding price into a single currency, addition preferential treatment value (if any), includes all taxes, fees and charges (if any).</b>
<b>ITB 34.1</b>	The maximum percentage of work volume may be increased is: <b>Not applicable.</b> The maximum percentage of work volume may be decreased is: <b>Not applicable.</b>
<b>ITB 34.2</b>	Additional purchase option: <b>Not applicable.</b> The maximum of additional purchase option: <b>Not applicable.</b>
<b>ITB 38.2</b>	Vietsovpetro's address: 105 Le Loi Str, Vung Tau ward, HCM City, Vietnam Tel: 84 254 3839 871 Fax: 84 254 3839 857
<b>ITB 39</b>	Address of organization, individual in charge of supervision:

Mr. Vu Mai Khanh – General Director of Vietsovpetro 105 Le Loi Str, Vung Tau ward, HCM City, Vietnam Fax: 84 254 3839 857
---------------------------------------------------------------------------------------------------------------------------------

## Chapter III. BID PROPOSAL EVALUATION CRITERIA

### Section 1: Verification and evaluation the eligibility of Bid Proposal

#### 1.1 Verification the Bid Proposal:

- a) Verify the number of original and copies of the bid proposal;
- b) Verify the documents comprising the original Bid proposal including: administrative documents, legal documents, Bidder's capacity and experience documents, technical proposal as stipulated in Invitation to Bid, in which there are: Application for Bidding, Consortium Agreement (if any), Power of Attorney for signing Application for Bidding (if any); Bid Bond/Deposit; documentary evidence establishing the Bidder's eligibility to bid; documentary evidence Bidder's capacity and experience; technical proposal; price proposal and any other relevant documents of Bid Proposal as stipulated in ITB 10;
- c) Verify the consistency of contents between the original and copies for detailed evaluation process of bidding package.

#### 1.2 Evaluation the eligibility of Bid Proposal:

A Bid proposal is considered eligibility when it fully meets the following requirements:

- a) The Bidder submits the original of Bid proposal.
- b) The Application for Bidding is signed and stamped (if any) by the legitimate representative of the bidder as required by Invitation to Bid. For consortium, the Application for Bidding is signed and stamped (if any) by the legitimate representatives of each member of the consortium or the authorized leader member of the consortium sign the Application for Bidding according to responsibilities in written agreement of consortium.
- c) Bidding prices in Application for Bidding must be detailed, fixed, indicated by numbers, words and in accordance with total bidding prices mentioned in Summary of bidding price table. Bidders are required not to propose different bidding prices or conditions that put Vietsovpetro in disadvantage.
- d) The validity period of the Bid proposal must meet the requirements stipulated in ITB 17.1.
- e) **The Bid Bond/Deposit must satisfy all the requirements as stipulated in ITB 18.3.**
- f) The bidder is not named in 02 or more Bid proposals as a main bidder (independent bidder or a member of consortium) in one bidding package. In case the bidding package is divided into many independent parts, the bidder is not named in 02 or more Bid proposals as the main bidder for the parts that bidder participates.
- g) For consortium, written agreement of consortium is signed and stamped (if any) by the legitimate representative of each member of the consortium and the consortium agreement must specify the detail scope of work and estimated respective percentage that each member will implement as Bidding Form 03, Chapter IV, Bidding Form.  
If the scope of supply includes only one unit/one piece and no related service, bidder is not allowed to enter into a consortium; in case that Bidders is still in a consortium, agreement of consortium shall be considered invalid and Bidder shall be rejected.
- h) The bidder is eligible as stipulated ITB 5.

Bidders who submit eligible bid proposals shall be considered and evaluated on their capacity and experience.

### Section 2: Capacity and experience evaluation criteria

Standards of competence and experience are mandated and listed in Table No. 01 (for bidders who are Non-manufacturers of goods within the scope of the bid package) or Table No. 02 (for bidders who are manufacturers of goods within the scope of the bid package). A

bidder's evaluation of competence and experience is subjected to whether it meets all standards. A subcontractor's competence and experience will not be taken into consideration when evaluating a bid proposal. The contractor itself must meet the evaluation standards of competence and experience.

In case the currency used in similar contracts or one of the following – Investor's payment confirmation for past contracts for the supply of goods, tax declarations, documents proving the bidder's competence and experience – is not VND: in the bid proposal, the bidder must convert them to VND as a basis for evaluation. [The conversion is subject to the exchange rate of Vietcombank's selling rate at the date of signing a similar contract.](#)

In case the Bidder participating in bidding is the parent company (for example, Corporation) assigning a subsidiary to perform part of the work in the bid package, the contractor must declare specifically which part using Form 11C Chapter IV. The evaluation of experience in fulfilling similar contracts is based on the value and volume of work that the parent company and subsidiary delivered in the bidding package.

For Consortium, capacity and experience will be defined by the aggregated capacity and experience of each member of Consortium, but it must be assured that each member of Consortium must satisfy the requirement of capacity and experience for the volume of work implemented by him; if any of the members in Consortium do not satisfy the capacity and experience criteria, the Consortium will be evaluated as fail to meet the requirement on capacity and experience.

Sub-contractors' capacity and experience will not be considered in the evaluation of the Bid proposal of main Bidder (unless the Invitation to Bid allows to use specialized sub-contractor). The main bidders themselves must satisfy criteria on capacity and experience (not considered the sub-contractors' capacity and experience).

In case application of pre-qualification, if there are changes in capacity and experience when submitting the bid proposal in comparison with the information in the evaluated pre-qualification documents, the bidders must update their capacity and experience; in case there is no change in bidders' capacity and experience, the bidders must send a written commitment that they still satisfy the bidding package's requirements.

If there is no pre-qualification, the evaluation of capacity and experience will be carried out in accordance with the following evaluation criteria, the bidders are considered "pass" the capacity and experience requirements if they satisfy all the criteria.

## 2.1. Criteria for evaluation of capacity and experience

The evaluation of capacity and experience will be carried out as in following table:

### CRITERIA TABLE FOR EVALUATION OF BIDDER'S CAPACITY AND EXPERIENCE

*(For Bidders who are Non-manufacturers<sup>(1)</sup> of goods under the scope of the bid package)*

**Table No. 01**

No.	Criteria on capacity and experience		Compliance Requirements			Documents
	Description	Requirement	Single Entity	Consortium		Submission Requirements
				All Members Combined	Each Member	
1.	Historical Contract Non-Performance <sup>(1)</sup> due to Bidder's fault	From January 01, year 2022 to Deadline for bid submission, the contractor does not have a contract for the supply of goods, not fulfilled through fault of the bidder.	Must meet requirement	not applicable	must meet requirement	Form 09
2.	Tax obligations fulfilment	Has fulfilled tax obligations of the last fiscal year before Deadline for bid submission.	Must meet requirement	not applicable	must meet requirement	Form 10

**Notes:**

<sup>(1)</sup> Non performance contracts due to Bidder's fault shall include all contracts where:

- Non performance contracts, as concluded by employer, and were not objected by the Bidder,
- Non performance, as concluded by the employer, and were so objected by the Bidder but fully settled against the Bidder by Arbitration or Court.

Non performance shall not include contracts where employer decision was overruled by the dispute resolution mechanism. Non performance must be based on all information on fully settled disputes or litigation, i.e. dispute or litigation that has been resolved in accordance with the dispute resolution mechanism under the respective contract or applicable law and where all appeal instances available to the Bidder have been exhausted.

Criteria on capacity and experience			Compliance Requirements			Documents
No.	Description	Requirement	Single Entity	Consortium		Submission Requirements
				All Members Combined	Each Member	
3.	Financial Capacity					
3.1	Financial Performance	Submission of financial statements for the latest <b>03 fiscal years</b> to demonstrate the current soundness of the Bidder's financial position. The Bidder's net worth for the last fiscal year to the Deadline for bid submission (calculated as the difference between total assets and total liabilities) should be positive	Must meet requirement	not applicable	must meet requirement	Form 10
3.2	Average Annual business activities Turnover (excluding VAT)	Minimum average annual turnover of following value within the latest <b>03</b> fiscal years <sup>(1)</sup> : <b>≥ USD 78.855,00 / VND 2.089.657.500</b> (In case Company of the Bidder established less than <b>03</b> years, the value of Average annual business activity turnover will be sum total value of business activity turnover and divide to total number of years have activities)	must meet requirement	must meet requirement	not applicable	Form 10

**Notes:**

<sup>(1)</sup> In case of Consortium, the evaluation of the turnover criteria will be total turnover of all members for compare and evaluation.

Criteria on capacity and experience			Compliance Requirements			Documents
No.	Description	Requirement	Single Entity	Consortium		Submission Requirements
				All Members Combined	Each Member	
4.	Experience on implementing Contracts of supplying similar goods	Requires <b>at least 01 contract for supplying of goods and equipment for the Oil and Gas industry / other industries</b> as described hereunder that has been successfully completed <sup>(1)</sup> as main Contractor (individually or partner of Consortium) or sub-contractor <sup>(2)</sup> within the last <b>05 years</b> to the Deadline for bid submission. Contract must have value equivalent to or greater than <b>USD 26.285,00 / VND 696.552.500</b>	must meet requirement	must meet requirement	must meet requirement (equivalent to the volume of work implemented)	Form 07A

**Notes:**

<sup>(1)</sup> “Successfully completed” means completion of all (80%) of contract scope of work. The contract is completed, ending the entire workload of such contract and the time of contract completion is the time of delivery / acceptance of the entire contract, regardless of the time of signing the contract.

<sup>(2)</sup> For contract implemented by bidder as member of Consortium or sub-contractor, only the amount of work implemented by Bidder itself will be considered.

Criteria on capacity and experience			Compliance Requirements			Documents
No.	Description	Requirement	Single Entity	Consortium		Submission Requirements
				All Members Combined	Each Member	
5.	The ability of performing warranty, maintenance, repair, overhaul and provision of spare parts and other after-sale services <i>(To be evaluated in the Technical evaluation stage)</i>	The bidder must be represented by an Agent (or Representative) who is available to carry out the Bidders' obligations such as warranty, maintenance, repair and provision of spare parts by one of following: - The bidder commits its capability in fulfilling obligations of warranty, maintenance, repair, supply of spare parts or providing after-sales services as required by the Invitation to Bid. <i>(as per required in the Technical requirement)</i> - The bidder signs a principle contract with an entity capable of fulfilling the obligations of warranty, maintenance, repair, supply of spare parts or providing after-sales services as required by the Invitation to Bid. <i>(as per required in the Technical requirement)</i>	must meet requirement	must meet requirement	must meet requirement (equivalent to the volume of work implemented)	

## CRITERIA TABLE FOR EVALUATION OF BIDDER'S CAPACITY AND EXPERIENCE

(For Bidders who are manufacturers<sup>(1)</sup> of goods under the scope of the bid package)

**(NOT APPLICABLE)**

No.	Criteria on capacity and experience		Compliance Requirements			Documents
	Description	Requirement	Single Entity	Consortium		Submission Requirements
				All Members Combined	Each Member	
1.	Historical Contract Non-Performance <sup>(2)</sup> due to Bidder's fault	From January 01, year ... to Deadline for bid submission, the contractor does not have a contract for the supply of goods, not fulfilled through fault of the bidder.	Must meet requirement	not applicable	must meet requirement	Form 09
2.	Tax obligations fulfilment	Has fulfilled tax obligations of the last fiscal year before Deadline for bid submission.	Must meet requirement	not applicable	must meet requirement	Form 07B

**Notes:**

<sup>(1)</sup> *Manufacturer is understood as an enterprise/manufacturing facility that produces goods itself or participates in the production process of goods or a subsidiary or parent company in charge of distributing and consuming products produced by the parent company and other subsidiaries within the Group or Corporation.*

<sup>(2)</sup> *Non performance contracts due to Bidder's fault shall include all contracts where:*

- *Non performance contracts, as concluded by employer, and were not objected by the Bidder,*
- *Non performance, as concluded by the employer, and were so objected by the Bidder but fully settled against the Bidder by Arbitration or Court.*

*Non performance shall not include contracts where employer decision was overruled by the dispute resolution mechanism. Non performance must be based on all information on fully settled disputes or litigation, i.e. dispute or litigation that has been resolved in accordance with the dispute resolution mechanism under the respective contract or applicable law and where all appeal instances available to the Bidder have been exhausted.*

Criteria on capacity and experience			Compliance Requirements			Documents
No.	Description	Requirement	Single Entity	Consortium		Submission Requirements
				All Members Combined	Each Member	
3.	Financial Capacity					
3.1	Financial Performance	Submission of financial statements ... <b>years</b> (from year ... to year ... or from year ... to year ...) to demonstrate the current soundness of the Bidder's financial position. The Bidder's net worth for the last fiscal year, (calculated as the difference between total assets and total liabilities) should be positive.	Must meet requirement	not applicable	must meet requirement	Form 10
3.2	Average Annual business activities Turnover	Minimum average annual turnover of following value within the latest ... fiscal years <sup>(1)</sup> <b>≥ USD [...] / VND [...]</b> (In case Company of the Bidder established less than 03 years, the value of Average annual business activity turnover will be sum total value of business activity turnover and divide to total number of years have activities)	must meet requirement	must meet requirement	not applicable	Form 10

**Notes:**

<sup>(1)</sup> In case of Consortium, The Evaluation of the turnover criteria will be total turnover of all members for compare and evaluation.

Criteria on capacity and experience			Compliance Requirements			Documents
No.	Description	Requirement	Single Entity	Consortium		Submission Requirements
				All Members Combined	Each Member	
4.	<b>Capacity of goods production</b>	<p>The bidder provides documents as proof of production capacity, including either:</p> <ul style="list-style-type: none"> <li>- The capacity of factories or production lines with minimum output of: ___ units/month;</li> </ul> <p>Or:</p> <ul style="list-style-type: none"> <li>- The highest output per month within the last ... years prior to the Deadline for bid submission: ___ units</li> </ul>	must meet requirement	must meet requirement	must meet requirement (equivalent to the volume of work implemented)	Form 07B

**Notes:**

*In case the goods are products produced domestically by a Vietnamese bidder (which may or may not have been sold in the market), the bidder must prove that the design capacity or production quantity complies with the requirements.*

*In case the bidder is both a manufacturer and a supplier (some goods or a part of the volume of goods offered by the bidder in the Bid proposal which are produced by the bidder, some other goods or a part of the volume of goods are purchased by the bidder from other manufacturers or suppliers to supply for the bidding package), in addition to declaring production capacity, the bidder shall also declare experience in performing similar contracts as prescribed in Section 4 – Table No. 01 of this Chapter. The evaluation of the bidder's experience will be done on the basis of providing the similar contract for supply of goods (in response to the part of goods bidder purchases from other manufacturers or suppliers) and the bidder's production capacity (in response to the part of goods that the bidder produces itself providing in the bidding package). Bidder may use documents such as sales invoices, inventory quantities, ... to prove the quantity produced in 01 month.*

Criteria on capacity and experience			Compliance Requirements			Documents
No.	Description	Requirement	Single Entity	Consortium		Submission Requirements
				All Members Combined	Each Member	
5.	The ability of performing warranty, maintenance, repair, overhaul and provision of spare parts and other after-sale services <i>(To be evaluated in the Technical evaluation stage)</i>	The bidder must be represented by an Agent (or Representative) who is available to carry out the Bidders' obligations such as warranty, maintenance, repair and provision of spare parts by one of following: - The bidder commits its capability in fulfilling obligations of warranty, maintenance, repair, supply of spare parts or providing after-sales services as required by the Invitation to Bid. <i>(as per required in the Technical requirement)</i> - The bidder signs a principle contract with an entity capable of fulfilling the obligations of warranty, maintenance, repair, supply of spare parts or providing after-sales services as required by the Invitation to Bid. <i>(as per required in the Technical requirement)</i>	must meet requirement	must meet requirement	must meet requirement (equivalent to the volume of work implemented)	

## 2.2. Evaluation Criteria for Key personnel (*Not applicable*)

## 2.3. Sub-contractors and Specialized Sub-contractors (*Not applicable*)

### Section 3: Technical evaluation criteria (see Part 2 – Chapter V)

### Section 4: Price evaluation criteria (**Lowest price method**)

Determination of lowest price as following steps:

Step 1: Determination of bidding price including all taxes, fees, charges (if any) arisen inside Vietnam and shall be taken into consideration exemption of import tax and VAT for imported goods from using List of exempted goods available for Vietsovpetro in Block 09-1;

Step 2: Rectification of errors (apply in accordance with Note (1));

Step 3: Adjustment of deviations (apply in accordance with Note (2));

Step 4: Determination of bidding price after rectification of errors, adjustment of deviations, discount deduction (if any);

Step 5: Conversion of bidding price into a single currency (if any);

Step 6: Determination of preferential treatment value (if any) as stipulated in ITB 28;

**Step 7: Ranking the bidders: the Bid proposal which has the lowest bidding price for the whole package after rectification of errors, adjustment of deviations, discount deduction (if any), conversion of bidding price into a single currency, addition preferential treatment value (if any), including all taxes, fees, charges (if any) arisen inside Vietnam and shall be taken into consideration exemption of import tax and VAT for imported goods from using List of exempted goods available for Vietsovpetro in Block 09-1 shall be ranked the first.**

The following content will be considered in the evaluation and ranking stage of contractors:

During the Bid evaluation stage, for proposal of goods originating from countries affected by armed conflict, in state of war, sanctioned or embargoed, and the importation of those may be interrupted and affect the contract performance and delivery schedule, Bidder must provide explanations and commitments on the ability to deliver goods for Vietsovpetro to consider and evaluate.

Based on the actual situation at that time, Vietsovpetro has the sole and exclusive right to review and decide to reject the bids, or not to continue the evaluation, if in the opinion of Vietsovpetro there is any risk to the contract performance and delivery schedule. In that case, the Vietsovpetro at its sole and absolute discretion will have the right to consider and remove these Bidders from the ranking list.

#### Notes:

##### **(1) Rectification of errors**

*Provided that the bid proposal substantially satisfies Invitation to Bid, Vietsovpetro shall rectify arithmetical errors and other errors on the following basis:*

*a) Arithmetical errors include mistakes from calculation such as: addition, subtraction, multiplication, division when calculating bidding price. If there is a discrepancy between the unit price and the total price, the unit price shall prevail and the total price shall be corrected; If there is unusual differences in unit price due to decimal errors (10 times, 100 times, 1000 times), the total price should be used as a legal basis for correction; when the bidder fills without price or “0” in the column of unit price and total price, price of this item shall be deemed to be allocated among the prices for the other items of work of the package and Bidder will not be paid for by Vietsovpetro during contract performance.*

*b) Other errors:*

*- If the Total price column is filled without the corresponding unit price, the unit price shall be determined by dividing the total price by the quantity; if the unit price is filled in, but the total price is*

missing, the total price shall be determined by multiplying the quantity by the unit price; if one of the items has the unit price and total price filled in, but the quantity is missing, the quantity shall be determined by dividing the total price by the unit price of that particular item. In case the aforesaid quantity that has been additionally defined is different from the quantity mentioned in the Invitation to Bid, that value difference is the deviation in the scope of supply, which shall be adjusted under regulations specified in Step 3;

- Mistake in Unit must be corrected to meet the requirements specified in the Invitation to Bid;
- Mistakes in using comas (instead of periods) and vice versa shall also be corrected in accordance with the written in Vietnamese customary. If Vietsovetro determines the obvious mistake in placing of comas and periods, the total price shall prevail and the unit price shall be corrected.
- If there is an error in a total corresponding to the addition of subtotals, the subtotals shall prevail and the total shall be corrected;
- If there is a discrepancy between words and numbers, the amount in words shall used as a legal basis for correction. If the amount expressed in words is incorrect, then the number after rectification of error as stipulated in this article should be used as a legal basis for correction.

## **(2) Adjustment of deviation**

- a) In case of deviation in the scope of supply compared to the Invitation to Bid, what is deficient shall be added, and what is redundant shall be subtracted according to respective unit price in the Bid proposal of bidder that has deviation;

In case of deficient deviation (lack of items of work in comparison with the scope of supply, lack of inland transportation cost to Vietsovetro warehouse/Vietsovetro port in case Bidder does not offer delivery term to Vietsovetro warehouse/Vietsovetro port), if there is no respective unit price in the Bid proposal with deficient deviation, the adjustment of deviation will be as follows:

### **- Lack of items of work in comparison with the scope of supply:**

The highest unit price offered for such item of Bid proposals which pass the Technical evaluation shall be used as legal basis for adjustment of deviation. In case the Bid proposals passed the Technical evaluation has no unit price, unit price in the value of bidding package shall be used as legal basis for adjustment of deviation. In case not having value of bidding package, unit price for calculating price of the bidding package shall be used as legal basis for adjustment of deviation.

In case only one bidder passes the Technical evaluation, adjustment of deviation shall be made based on respective unit price in the Bid proposal of this bidder; In case this Bid proposal has no respective unit price, unit price in value of bidding package shall be used. In case not having value of bidding package, unit price for calculating price of the bidding package shall be used as legal basis for adjustment of deviation.

### **- Lack of inland transportation cost to Vietsovetro warehouse/ Vietsovetro port:**

In case Bidder does not offer delivery term to Vietsovetro warehouse/ Vietsovetro port and not having value/unit price for inland transportation cost to Vietsovetro warehouse/Vietsovetro port, unit price in the value of bidding package shall be used as legal basis for adjustment of deviation. In case of not having unit price in the value of bidding package, the following rates shall be used as legal basis for adjustment of deviation:

*The inland transportation cost = 0.25% x Total proposed bid priceb*

- b) In case bidder has discount letter, rectification of errors and adjustment of deviation shall be made based on bidding price without discount. Percentage (%) of deficient deviation shall be determined on basis of comparison of bidding price in Application for Bidding.

## **Section 5: Technical alternative (if applicable)**

Bidder is allowed to submit Technical alternative and requested to identify clearly which is “**The Main offer**” and which is “**The alternative offer**” in the Proposal.

Note: Technical alternatives are only considered when main solution meets requirements and bidder is ranked first. In this case, bidder shall provide all information necessary for evaluation of the alternatives by Vietsovetro, including notes, drawings, technical specifications, progress of supply and other relevant information

**Section 6: Bidding package with multiple independent parts (*Not applicable*)**

If the bidding package is divided into multiple independent parts as stipulated in ITB 1.2, implement as follows:

1. The evaluation and approval of the winning of bid will be carried out on the basis that the total proposed bid winning prices of the bidding package are lowest (for lowest price method); the total evaluated prices are lowest (for evaluated price method); the total proposed bid winning prices shall not exceed the approved value of bidding package but are not compared to the estimated value of each part.
2. There is one contract if only one bidder wins all the parts of the bidding package. There are many contracts if many bidders win the different parts of the bidding package.

**Section 7: The right to unilaterally terminate contract negotiations with the first-ranked contractor in in contract negotiation satge.**

For the proposal of goods originating from countries affected by armed conflict, in state of war, sanctioned or embargoed, and the importation of the those may be interrupted and affect the contract performance and delivery schedule, explanations and commitments on the ability to deliver goods must be provided by the Bidder for Vietsovpetro to consider and evaluate.

Based on the actual situation at that time, Vietsovpetro will have the sole and exclusive right to review and decide to reject the proposals of those goods, or not to continue the evaluation, if in the opinion of Vietsovpetro there is any risk to the contract performance and delivery schedule. In that case, Vietsovpetro at its sole and absolute discretion will have the right to stop contract negotiation, and the next ranked bidder will be invited to negotiate the contract.

## Chapter IV. BIDDING FORMS

No.	Bidding Form	Performance	Responsibility for performance	
			Vietsovetro	Bidder
1.	<b>Form 01. Application for bidding form</b>	Submission with Bid Proposal		X
2.	Form 02. Power of Attorney			X
3.	Form 03. Consortium Agreement			X
4.	Form 04A. Guarantee for Bid Participation ( <i>Bid Bond</i> ), applicable to independent bidders			X
5.	Form 04B. Guarantee for Bid Participation ( <i>Bid Bond</i> ), applicable to consortium bidders			X
6.	Form 04C. Form of Deposit for bid participation	Submission with Bid Proposal		X
7.	Form 05. Bidder's information form			X
8.	Form 06. Information form for consortium bidders			X
9.	Form 07A. Similar contract performed by bidder ( <i>applicable to commercial bidders</i> )			X
10.	Form 07B. Declaration of goods production capacity ( <i>applicable to bidders who are manufacturers</i> )			X
11.	Form 08A. Proposed Key Personnel			X
12.	Form 08B. Profession skill curriculum vitae of key personnel			X
13.	Form 08C. Professional Experience			X
14.	Form 09. Historical Contract Non-Performance for the supply of goods due to fault of the bidder in the past.			X
15.	Form 10. Bidder's Financial Status			X
16.	Form 11A. Scope of work using sub-contractors			X
17.	Form 11B. List of specialized sub-contractors			X
18.	Form 11C. List of subsidiaries and member companies delivering work in the bidding package			X
19.	Form 12. Summary of bidding prices			X
20.	Form 12A. Bidding price schedule of goods ( <i>manufactured, processed outside Vietnam</i> )			X
21.	Form 12B. Bidding price schedule of goods ( <i>domestically manufactured, processed or goods manufactured,</i>			X

No.	Bidding Form	Performance	Responsibility for performance	
			Vietsovpetro	Bidder
	<i>processed outside Vietnam but already imported and being offered in Vietnam)</i>			
22.	Form 13. Bidding price schedule for related services			X
23.	Form 14A. Spare parts for replacement ( <i>Optional Scope</i> ) for Goods manufactured, processed outside Vietnam)			X
24.	Form 14B. Spare parts for replacement ( <i>Optional Scope</i> ) for Goods domestically manufactured, processed or goods manufactured, processed outside Vietnam, but already imported and being offered in Vietnam			X
25.	Form 15A. Declaration of goods with bid preferential treatments			X
26.	Form 15B. Costs of goods manufactured domestically with bid preferential treatments ( <i>in case of declaration for cost of import</i> )			X
27.	Form 15C. Costs of goods manufactured domestically with bid preferential treatments ( <i>in case of declaration for cost of manufacturing in Vietnam</i> )			X

**APPLICATION FOR BIDDING<sup>1</sup>**

Date: ..... (Date of signing application for bidding)

Name of bidding package: ..... (Name Package according to Bid Announcement)

Name of project: ..... (Name project)

Bid invitation No.: ..... (In case of limited tendering)

Attention to: \_\_\_\_\_ (full name and address of Vietsovpetro)

After studying the Invitation to Bid and the documents for amendment of the Invitation to Bid [insert the code of the amendment documents, if any] that we have received, we [insert the name of the bidder] commit to execute [name of Bidding package] as required by the Invitation to Bid at the total amount of [specify in number, in words, and currency of bid proposal]<sup>2</sup> and the summary of bidding price.

In addition, we voluntarily offer a discount with amount: \_\_\_\_\_ [specify in number, in words, and currency of bid proposal].

The bidding price after application of discount is: \_\_\_\_\_ [specify in number, in words, and currency of bid proposal]<sup>3</sup>.

Validity of the Proposal<sup>4</sup>: \_\_\_\_\_ [write the validity period from the deadline for submission of bids in accordance with the BDS] days, from the deadline for submission of bids.

Bid Security: \_\_\_\_\_ [State the value in figures, in words and in currency of the bid security].

Validity of Bid Security: \_\_\_\_\_ [insert validity period from deadline for submission of bids].

Time for contract implementation: ..... (Total time to perform all work required in Bidding package)<sup>5</sup>.

We commit:

1. We are not in the process of carrying out dissolution procedures or having its business registration certificate, cooperative registration certificate, cooperative union registration certificate, or cooperative group registration certificate revoked, not in a case of insolvency according to the provisions of the law on bankruptcy (not in the process of ceasing operations or having its business household registration certificate revoked for Bidders that are household businesses).
2. We do not violate regulations on ensuring fair competition in bidding.
3. We have fulfilled the tax liabilities of the most recent fiscal year prior to the deadline for submission of bids.
4. We are not being under suspension from participating in bidding according to the provisions of the law on bidding.
5. We are not being prosecuted for criminal liability (the household owner is not being prosecuted for criminal liability in case the bidder is a business household).
6. We do not proceed any practices of corruption, bribe, collusion, obstruction and other violated provisions of the law on procurement when participating this package.
7. The information declared in the bid is truthful.
8. In case of winning the bid, the Proposal and clarification, supplemental documents of the Proposal constitute the agreement of responsibilities between the two parties until the contract is signed.
9. If our bid is accepted, we shall furnish a performance security as specified in ITB 37.1 of the Bidding document.

**Legal representative of bidder**  
**(Name, position, signature and stamp)**

**Notes:**

<sup>1</sup> Application for bidding must be filled with sufficient and accurate information of Vietsovpetro, Bidder, the validity duration of Bid proposal, signed and stamped by legitimate representative of the bidder.

<sup>2</sup> Bidding prices in Application for bidding must be specific, fixed, indicated by numbers, words and in accordance with total bidding prices mentioned in price list. Bidders are required not to propose different bidding prices or conditions that put Vietsovpetro in disadvantage. In case of multiple parts, the Bidder must write the total bidding price of each parts and total bidding price of all parts that bidder participates.

<sup>3</sup> Specify discount for the whole bidding package or for one or many works, items (specify detailed discounted works, items).

<sup>4</sup> The validity of Bid proposal shall be counted from the date of Deadline for bid submission to the last date of validity period as stipulated in the Invitation to Bid. From the time of Deadline for bid submission until 24:00 of the date which has the deadline for bid submission is considered as one day.

<sup>5</sup> Duration of contract implementation in Application for bidding must be in accordance with Technical proposal and completion schedule specified in the Bid Proposal.

<sup>6</sup> If legitimate representative of bidder authorizes the subordinate to sign the application for bidding, the bidder must submit Power of Attorney according to Form 02 of this Chapter; if the company's Charter/regulations or other related documents have the assignment of responsibilities to subordinates to sign application for bidding, the bid proposal must include these documents (no Power of Attorney is required in accordance with Form 02 of this Chapter).

For consortium, the application for bidding must be signed by the legitimate representative of each member of the consortium, except in Consortium agreement (as in Form 03 of this chapter), the members of Consortium agree to authorize the leader member of the consortium to sign the Application for bidding. If each member of consortium has its own authorization, apply as for independent bidders. If the bidder wins the bidding package, the bidder must present to the Employer the notarized/certified copy of these documents before signing the contract. If the information declared is not accurate, the bidder is considered violation of ITB 4.

**POWER OF ATTORNEY<sup>1</sup>**

Date \_\_\_\_\_/\_\_\_\_\_/20\_\_\_\_\_ at (name of place) .....

I, ..... [*insert Name, ID/passport number, position of Legitimate representative of the bidder*],  
the Legitimate representative of \_\_\_\_\_ [*insert the bidder name*] at \_\_\_\_\_ [*insert address*]

To issue this Power of Attorney to:

Mr/Mrs \_\_\_\_\_

ID/Passport number \_\_\_\_\_

Position \_\_\_\_\_

To do, execute and perform the following acts and things during the process of participating the Bidding package \_\_\_\_\_ (*Name of Bidding Package*) of Project \_\_\_\_\_ (*Name of project*) held by Vietsovpetro:

- [- Sign the Application for bidding form;
- Sign the Consortium agreement (if any);
- Sign all documents, correspondences to Vietsovpetro during the bidding process, including the written requests to clarify Invitation to Bid, written clarification of Bid proposal, or written requests to withdraw, modify or substitute the bid proposal;
- Negotiate and finalize contract with Vietsovpetro;
- Sign the Bidder's arising claims (if any);
- Sign contract with Vietsovpetro (if awarded the Bidding package)]<sup>2</sup>;

The Attorney shall lawfully perform acts within the scope of Power of Attorney as the legitimate representative of \_\_\_\_\_ (*name of bidder*).

The Mandator, [*name of Legitimate representative of the bidder*] will be completely responsible for acts performed by the Attorney, \_\_\_\_\_ [*name of the Attorney*] in the scope of Power of Attorney.

This Power of Attorney is valid for the period from \_\_\_\_\_ to \_\_\_\_\_<sup>3</sup> and will be made in \_\_\_\_\_ originals, \_\_\_\_\_ of which will be retained by Mandator; \_\_\_\_\_ of which will be retained by Attorney and the rest will be retained by Vietsovpetro. All original copies hereof are identical and legally equal.

Attorney  
(Signature)  
(Name, position and stamp (if any))

Mandator  
(Signature)  
(Name, position and stamp (if any))  
of Legitimate representative of the bidder)

**Notes:**

<sup>1</sup> The original of this Power of Attorney must be submitted to Vietsovpetro together with the application for bidding as stipulated in ITB 20.3. Legitimate representative of bidder gives the power of attorney to the deputy, subordinate, branch's manager, chief of bidder's representative office to perform one or more above mentioned listed acts. The stamp used in case of power of attorney can belong to the bidder or to the entity of Attorney. The Attorney can not subsequently give this authorization to another.

<sup>2</sup> The scope of Power of Attorney may include one or more above mentioned listed acts.

<sup>3</sup> Specify the date the power of attorney come into force and expiry date, in accordance with the bidding process.

**CONSORTIUM AGREEMENT<sup>1</sup>**

\_\_\_\_\_, day \_\_\_ month \_\_\_ year \_\_\_\_\_

Bidding package: \_\_\_\_\_ [*name of bidding package*]Under the project: \_\_\_\_\_ [*name of project*]Based on the Invitation to Bid \_\_\_\_\_ [*name of bidding package*] date \_\_\_ month \_\_\_ year \_\_\_\_\_ [*date recorded on the Invitation to Bid*]

We, the representatives of the parties sign the Consortium Agreement, including:

**Names of Consortium members** \_\_\_\_\_ [*name of each consortium member*]

Represented by Mr./Ms.: \_\_\_\_\_

Position: \_\_\_\_\_

Address: \_\_\_\_\_

Tel: \_\_\_\_\_

Fax: \_\_\_\_\_

E-mail: \_\_\_\_\_

Account: \_\_\_\_\_

Tax code: \_\_\_\_\_

Power of Attorney No. \_\_\_ date \_\_\_ month \_\_\_ year \_\_\_\_\_ (*in case of authorization*).

The parties (hereinafter referred to as members) agreed to sign this Consortium Agreement with the following contents:

**Article 1. General principles**1. The members voluntarily establish a Consortium to participate in the bidding package \_\_\_\_\_ [*name of bidding package*] under the project \_\_\_\_\_ [*name the project*].2. The members agree the name of the Consortium for any transactions related to this package as: \_\_\_\_\_ [*name of the Consortium as Agreement*].

3. The members commit that there is not any member to arbitrarily join independently in this bidding package or join consortium with other members to participate in this bidding package. In case of winning the bid, all members of the Consortium shall sign the Contract and there is not any member to have the right to refuse performance of the responsibilities and obligations stipulated in the Agreement. In case a member of the Consortium refuses to fulfill their own responsibilities as agreed or violates the provisions of the signed contract, such member shall be handled as follows:

- Compensating for damages to the parties in the consortium;
- Working with members of the Consortium to compensate for all damages to the Vietsovpetro in accordance with the provisions stipulated in the Contract (corresponding to the proportion of each member specified in Article 2 of this Agreement);
- Other forms of handling \_\_\_\_\_ [*Specify other forms of handling*].

**Article 2. Assignment of responsibilities**Consortium members agree to assign responsibilities for implementation of the bidding package \_\_\_\_\_ [*write name of bidding package*] under the project \_\_\_\_\_ [*write name of project*], for each member as follows:

1. Leader of the consortium:

The parties agree to authorize to \_\_\_\_\_ [*Write name of a party*] as a leader of the consortium, representing the Consortium in the following part of work<sup>2</sup>:

- Signing the application of bidding;

- Signing all documents, correspondences to Vietsovpetro during the bidding process, including the written requests to clarify Invitation to Bid, written clarification of Bid proposal, or written requests to withdraw, modify or substitute the bid proposal;
- Performing Bid Bond on behalf of Consortium;
- Participating in the process of negotiation and finalization of the Contract;
- Performing Performance Bond for the entire Consortium in case the Consortium wins the bid;
- Signing the Bidder's arising claims (if any);
- Performing all obligations of the Consortium which are not specified in the Table of Responsibility between the Consortium members in item 2 as follows;
- Performing other works except for signing Contract \_\_\_\_\_ [specify the detail content of other jobs (if any)].

2. The members of the Consortium agree to assign the responsibility of members as following table<sup>3</sup>:

No.	Name	Content of assigned work	Respective percentage to total bidding price	Amount by percentage to total bidding price
(1)	(2)	(3)	(4)	(5)
1.	Name of the first member (Leader of the Consortium)	- Work 1: _____	_____ %	_____ VND/USD
		- Work 2: _____		
		- Work 3: _____		
		.....		
2.	Name of the second member	- Work 1: _____	_____ %	_____ VND/USD
		- Work 2: _____		
		- Work 3 _____		
....	.....	....		
<b>Total</b>		<b>All work of bidding package</b>	<b>100%</b>	<b>_____ VND/USD</b>

3. The payment method for the Consortium in case of winning the bid and signing a contract with [Vietsovpetro](#) is as follows:

- [Vietsovpetro](#) shall make direct payment to each member of the Consortium in accordance with the payment schedule specified in the Contract with the distributed amount corresponding to the proportion of workload agreed by the Consortium members and shown in column (4) of the Table of Responsibility in item 2 of this Consortium Agreement.
- Each member of the Consortium shall issue a Legal Invoice in accordance with the amount of the work performed by such Consortium member pursuant to the progress of each payment specified in the Contract.

### Article 3. Validity of Consortium Agreement

1. This Consortium Agreement valid from its signing date.
2. This Consortium Agreement shall be determined to be invalid in the following cases:
  - In case the Consortium wins the bid, this Consortium Agreement is an integral part of the contract signed with the Investor ... and shall only be terminated when the parties fulfill their responsibilities and obligations and complete the liquidation of the contract;
  - The parties agree to terminate;
  - The Consortium does not win the bid;

- Cancellation of bidding package under the project as notified by the Vietsovpetro.

Consortium Agreement is made in \_\_\_\_ copies, each party keeps \_\_\_\_ copy, each having equal legal force and authenticity.

**LEGAL REPRESENTATIVE OF CONSORTIUM LEADER**

**[Full name, title, signature and stamp]**

**LEGAL REPRESENTATIVE OF CONSORTIUM MEMBERS**

**[Full name of each member, title, signature and stamp]**

**Notes:**

<sup>1</sup> Depending on the size and nature of bidding package, the content of agreement as in this form can be amended appropriately. If the bidding package is divided into multiple independent parts, the consortium agreement must specify clearly the name, reference number of parts that the consortium participates, specify mutual responsibility and separate responsibility of each member in accordance with respective parts that bidder participates.

<sup>2</sup> The scope of authorization may include one or more above mentioned listed acts.

<sup>3</sup> Bidder must specify the detail work and the estimated percentage of respective value that each member will implement, mutual responsibility and separate responsibility of each member, including head member of the Consortium.

**GUARANTEE FOR BID PARTICIPATION<sup>1</sup>**  
**(BID BOND)**  
*(Applicable to independent bidder)*

**Beneficiary:** VIETSOVPETRO  
 105 LE LOI STR, VUNGTAU CITY, S.R. VIETNAM.  
 (Hereinafter referred to as the employer)

**Date:** \_\_\_\_\_ *[Insert date of issue]*

**BID GUARANTEE No.:** \_\_\_\_\_ *[Insert guarantee reference number]*

**Guarantor:** \_\_\_\_\_ *[Insert name and address of place of issue, unless indicated in the letterhead]*

We have been informed that ..... *[insert name of the Bidder.]* (hereinafter called "the Applicant") will participate bid for execution of the bidding package \_\_\_\_\_ *[name of the bidding package]* under project \_\_\_\_\_ *[name of the project]* according to Bid Invitation Letter No/Bid Announcement No. \_\_\_\_\_. *[insert No. of Bid Invitation letter/ Bid Announcement No.]*

We *[name of the bank]*, hereinafter referred to as "the bank", pledge Beneficiary to guarantee for the bidder to participate in bidding for this bidding package with an amount of *[specify the value in number, in words, and the currency in use]*.

This guarantee is effective for .....<sup>2</sup>.days, from the date.....month.....year<sup>3</sup>

At the request of the Applicant, we, as Guarantor, **hereby unconditionally and irrevocably** undertake to pay the Beneficiary any sum or sums not exceeding in total an amount of *[insert amount in figures, insert amount in words]* within 05 working days upon our receipt of written notice from Beneficiary stating without requiring proof that bidder violates the regulations as follows:

1. Bidder has withdrawn its Bid proposal after Deadline for bid submission and during the validity period of bid proposal;
2. Bidder violating Law on Bidding leads to cancellation of Bid in accordance with **Point d, ITB 32.1;**
3. Bidder fails or refuses to conduct contract negotiations **within 07 days** from the date receipt of notification for negotiation of contracts by Vietsovpetro; or Bidder conducts contract negotiations but withdraws its Bid proposal leading to failed contract negotiations, except for force majeure;
4. Bidder fails or refuses to conduct contract finalization **within 20 days** from the receipt date of Bid Award Notification from Vietsovpetro or bidder finalized contract but refuses to sign contract, except for force majeure; or **the bidder refuses to sign the contract within ten (10) days from the date of completion of the contract, except in cases of force majeure;**
5. Bidder does not conduct performance bond in accordance with **ITB 37.**

The said guarantee amount shall be paid by Guarantor forthwith to Beneficiary notwithstanding any contestation or protest by Guarantor or Applicant or by any third party, and irrespective of whether or not there is any dispute between Applicant and Beneficiary in respect of or relating to the Bidding package or in respect of any other matter and irrespective of whether or not such said dispute, if any, has been settled, resolved, litigated, or adjudicated upon otherwise howsoever.

If Applicant is selected as successful bidder: This guarantee will expire immediately if the Applicant signs contract and submit Performance Bond to Beneficiary in accordance with agreement in contract.

If Applicant is not selected as successful bidder: This Guarantee will expire immediately after we receive a copy of the Beneficiary's notification to the Applicant about the result of the Bidder selection; within 30 days after the validity period of bid proposal.

Any demand for payment under this guarantee must be received by us at the office indicated above on or before that date.

**Legitimate representative of the bank  
(Specify name, title, sign and stamp)**

**Notes:**

<sup>1</sup> Apply if Bid Guarantee is in form of Letter of Guarantee from financial institution or foreign bank's branches which is legally operating in Vietnam.

<sup>2</sup> Insert as stipulated in BDS 18.2.

<sup>3</sup> Insert Deadline for bid submission as stipulated in BDS 19.1.

**GUARANTEE FOR BID PARTICIPATION<sup>1</sup>**  
**(BID BOND)**  
*(Applicable to consortium bidders)*

**Beneficiary:** VIETSOVPETRO

105 LE LOI STR, VUNGTAU CITY, S.R. VIETNAM

(Hereinafter referred to as the employer)

**Date:** \_\_\_\_\_ *[Insert date of issue]*

**BID GUARANTEE No.:** \_\_\_\_\_ *[Insert guarantee reference number]*

**Guarantor:** \_\_\_\_\_ *[Insert name and address of place of issue, unless indicated in the letterhead]*

We have been informed that ..... *[insert name of the Bidder]*<sup>2</sup> (hereinafter called "the Applicant") will participate bid for execution of the bidding package \_\_\_\_\_ *[name of the bidding package]* under project *[name of the project]* according to Bid Invitation letter No. \_\_\_\_\_ *[name No. of Bid Invitation letter]*.

We *[name of the bank]*, hereinafter referred to as "the bank", pledge Beneficiary to guarantee for the bidder to participate in bidding for this bidding package with an amount of *[specify the value in number, in words, and the currency in use]*.

This guarantee is effective for .....<sup>3</sup>.days, from the date ..... month ... year<sup>4</sup>

At the request of the Applicant, we as Guarantor, hereby unconditionally and irrevocably undertake to pay the Beneficiary any sum or sums not exceeding in total an amount of \_\_\_\_\_ *[insert amount in figures, insert amount in words]* within 05 working days upon our receipt of written notice from Beneficiary stating without requiring proof that bidder violates the regulations as follows:

- 1) Bidder has withdrawn its Bid proposal after bid submission deadline and during the validity period of bid proposal;
- 2) Bidder violating Law on Bidding leads to cancellation of Bid in accordance with **Point d, ITB 32.1**;
- 3) Bidder fails or refuses to conduct contract negotiations **within 07 days** from the date receipt of notification for negotiation of contracts by Vietsovpetro; or Bidder conducts contract negotiations but withdraws its Bid proposal leading to failed contract negotiations, except for force majeure;
- 4) Bidder fails or refuses to conduct contract finalization **within 20 days** from the receipt date of Bid Award Notification from Vietsovpetro or bidder finalized contract but refuses to sign contract, except for force majeure; or **the bidder refuses to sign the contract within ten (10) days from the date of completion of the contract, except in cases of force majeure**;
- 5) Bidder does not conduct performance bond in accordance with **ITB 37**.

If any member of consortium \_\_\_\_\_ *[insert name of consortium]* violates the Law, that leads to the Bid Bond not to be returned as specified in Point b, ITB 18.5 of Invitation to Bid, then the Bid Bond of all consortium members shall not be returned.

The said guarantee amount shall be paid by Guarantor forthwith to Beneficiary notwithstanding any contestation or protest by Guarantor or Applicant or by any third party, and irrespective of whether or not there is any dispute between Applicant and Beneficiary in respect of or relating to the Bidding package or in respect of any other matter and irrespective of whether or not such said dispute, if any, has been settled, resolved, litigated, or adjudicated upon otherwise howsoever.

This guarantee will expire: (a) if the Applicant is the successful Bidder, upon our receipt of copies of the contract agreement signed by the Applicant and the performance security issued to the Beneficiary upon the instruction of the Applicant; or (b) if the Applicant is not the successful Bidder, upon the earlier of our receipt of a copy of the Beneficiary's notification to

the Applicant of the name of the successful bidder within 30 days after the expiration of Bid Proposal.

Any demand for payment under this Bid Bond must be received by us at the office on or before that date.

**Legitimate representative of the bank  
(Specify name, title, sign and stamp)**

**Notes:**

<sup>1</sup> Applying in case the bid security (bank security) is a letter of guarantee of credit institutions or foreign banks' branches which are established under Vietnamese law. The bank is recommended to use this Bid security (bid bond) form, in case of applying for other different forms that violates one of following regulations: bid security has lower value than required, the validity period of bid security is shorter than regulation prescribed in ITB 18.2, invalid name of Beneficiary, not original and without valid signature or with the disadvantageous conditions to Vietsovetro, bid security shall be invalid.

<sup>2</sup> Bidders' name can be one of following cases:

- Name of consortium participates in bid, for instance consortium bidder A + B participates in bid, name of bidders shall be written "Consortium bidder A + B";
- Name of the member undertakes implementation of bid security for the entire consortium or for other partners in consortium, for instance consortium A + B + C participates in bid, case of the consortium agreement appointed bidder A performing bid security for whole consortium, the name of bidder shall be "Bidder A (on behalf of consortium bidder A + B + C), in case the consortium agreement appointed bidder B performing bid security for bidder B and C, then name of bidder shall be written as "Bidder B (for the behalf of bidder B and C)";
- Name of consortium's member perform separate the bid security;

<sup>3</sup> Insert as prescribed in BDS 18.2.

<sup>4</sup> Insert date deadline for bid submission in accordance with BDS 19.1.

**FORM OF DEPOSIT FOR BID PARTICIPATION**

Date: ..... (Date of signing application for bidding)

Name of bidding package: ..... (Name Package according to Bid Announcement)

Name of project: ..... (Name project)

Bid invitation No.: ..... ( In case of limited tendering)

Attention to: \_\_\_\_\_ (full name and address of employer)

With reference to the above mentioned bidding package, we [insert the name of the bidder] hereby would like to confirm as follows:

1. In lieu of the submission of Bid Bond issued by a bank, [insert the name of the bidder] shall implement bid guarantee for [name of bidding package] in the form of transfer to **Vietsovpetro**'s bank account a deposit amount equivalent to the Bid Bond amount specified in the ITB, i.e [specify in number, in words, and currency of deposit]
2. Bidder confirm that Bidder shall comply all conditions as stipulated in Bid bond form of ITB. (In the event that Bidder confirms not to comply all conditions in the Bid bond's form in ITB, Bidder's bidding proposal shall not be evaluated)
3. After [insert the required bid bond validity period] days from the bid closing date ....., **Vietsovpetro** shall transfer deposit amount above to [insert the name of the bidder]'s account. [insert the name of the bidder] shall be responsible for all the bank fees in connection with this transfer.

4. Vietsovpetro's bank account:

Beneficiary's name: Vietsovpetro

Beneficiary's Bank: Joint Stock Commercial Bank for Foreign Trade of Vietnam – Vungtau Branch

Account Number: 008.100.00000.11 (VND)

0081370000029 (USD)

**Legal representative of bidder**  
(Name, position, signature and stamp)

**Notes:**

Along with this letter, bidder must enclose the Payment order or appropriate document evidencing that bidder executed the payment to Vietsovpetro account.

**BIDDER'S INFORMATION FORM<sup>1</sup>**

Date: \_\_\_\_\_

NCB No. and title: \_\_\_\_\_

Bidder's name: \_\_\_\_\_ [*specify Bidder's name*]*In case of consortium, insert name of each partner in consortium*Place of business registration: \_\_\_\_\_ (*indicate province/city of Constitution*)Year of business founding / incorporation \_\_ [*year of company founding*]Bidder's legal address (*in country of registration*)

Bidder's legitimate representative information:

Name:

Address:

Telephone/fax numbers:

E-mail address:

- a. Attached are copies of original documents: Articles of Incorporation, Business Registration, Decision of Establishment or equivalent documents of constitution or association issued by authority of country where Bidder is operating.
- b. Included the organizational chart.

**Legal representative of bidder****(Name, position, signature and stamp)****Notes:**<sup>1</sup> *In case of consortium Bidder, each consortium member must declare this form.*

**INFORMATION FORM FOR CONSORTIUM BIDDER'S MEMBERS<sup>1</sup>**

Date: \_\_\_\_\_

Bid package No. and titles: \_\_\_\_\_

Consortium Bidder's name:

Consortium member's name:

Consortium member's country of registration:

Consortium member's year of foundation:

Consortium member's legal address in country of registration:

Consortium member's legitimate representative information:

Name:

Address:

Telephone/fax numbers:

E-mail address:

1. Attached are copies of original documents of: Business Registration of Company, Certificate of Investment, Decision of Establishment, etc.
2. Included is the organizational chart.

**Legal representative of bidder**  
**(Name, position, signature and stamp)**

**Notes:**

<sup>1</sup> *In case of consortium Bidder, each consortium member must declare this form.*

**SIMILAR CONTRACT PERFORMED BY BIDDER<sup>1</sup>***(Applicable to commercial bidders)*

Date \_\_ month \_\_ year \_\_

Bidder's name: \_\_\_\_ *[full name of bidder]*

Descriptions of each contract should contain following information:

Name and contract number	<i>[Full contract name and number]</i>		
Contract signing date	<i>[Date, month, year]</i>		
Completion date	<i>[Date, month, year]</i>		
Contract Value <sup>(3)</sup>	<i>[Total signed contract value and the original currency]</i>		Equivalent to ____ VND
If the bidder is a consortium member, provide a summary of the work undertaken and its value	<i>[Summary of the work]</i>	<i>[Value of the work undertaken (amount in original currency and %)]</i>	Equivalent to ____ VND
Project or Procurement name	<i>[Full name of the project/procurement estimate whose contract is being declared]</i>		
Name of Investor:	<i>[Full name of the Investor in the contract being declared]</i>		
Address: Telephone/fax: Email:	<i>[Full current address of the Investor]</i> <i>[Phone number, fax number including country code, area code]</i> <i>[Email address]</i>		
<b>Describe similarities in accordance with Section 2.1 of Chapter III<sup>2</sup></b>			
1. Type of goods	<i>[Correct type]</i>		
2. Fulfilled contract value <sup>3</sup>	<i>[Actual contract value fulfilled based on acceptance value, contract liquidation]</i>		
3. Scale	<i>[Scale according to the contract]</i>		
4. Other characteristics	<i>[Other characteristics, if needed]</i>		

**Legal representative of bidder****(Name, position, signature and stamp)****Notes:**

*The contractor shall carefully study the Invitation to Bid and proposes similar contracts to ensure the requirements of the Invitation to Bid are complied.*

<sup>1</sup> *In case of consortium, each member must declare according to this Form.*

<sup>2</sup> *Bidders only declare the similar content with the requirements of the bidding package.*

<sup>3</sup> *In case the contract value is not in VND, it shall be converted to VND at the exchange rate specified in Section 2 of Chapter III as a basis for evaluation.*

**DECLARATION OF GOODS PRODUCTION CAPACITY**  
*(Applicable to bidders who are manufacturers)*

The number of factories and production facilities (collectively referred to as factories): \_\_\_\_\_  
*[Number of factories]*

For each factory, the bidder declares the following information:

Factory Name:	<i>[Factory name]</i>
Address:	<i>[Factory address]</i>
Total investment:	<i>[Total investment]</i>
Design capacity:	<i>[Design capacity]</i>
Effective capacity:	<i>[Effective capacity of last year]</i>
Production standard:	<i>[Current production standard, if applicable]</i>
Number of employees:	<i>[Total number of employees working at the factory]</i>

**Legal representative of bidder**  
**(Name, position, signature and stamp)**

**Notes:**

*For a consortium, each member of the consortium shall declare using this Form.*

**PROPOSED KEY PERSONEL**

The Bidder shall declare its key personnel as required in Section 2 of Chapter III and shall demonstrate its capability to mobilize these people to deliver the bidding package. Key personnel may be on the contractor's payroll or mobilized by the bidder. In case the key personnel declared by the bidder in its bid proposal does not meet the requirements or the contractor cannot demonstrate mobilization capability (including cases where said personnel has been mobilized for another contract with overlapping execution timeline), Vietsovetro shall allow the bider to make addition or replacement. The bidder is allowed to make addition or replacement once for each position for a suitable period of time not less than 03 working days. In case the bidder does not have a replacement comlying the Invitation to Bid's requiments, the contractor shall be disqualified. In all cases, if the bidder declares personnel in a dishonest manner, making replacement shall not be allowed, the bid proposal shall be disqualified and the bidder shall be considered fraudulent according to the provisions of legislation on bidding or other relevant legislation and penalized accordingly.

1.	Job position [ <i>detailed job position in the bidding package</i> ]
	Name [ <i>name of key personnel</i> ]
2.	Job position [ <i>detailed job position in the bidding package</i> ]
	Name [ <i>name of key personnel</i> ]
3.	Job position
	Name
4.	Job position
	Name
5.	Job position
	Name
—	Job position
	Name

**Legal representative of bidder**  
**(Name, position, signature and stamp)**

**PROFESSIONAL CURRICULUM VITAE OF KEY PERSONNEL**

The Bidder must supply all required information below and attach certified copies of original related documents.

<b>Position</b>		
<b>Personnel Information</b>	Name	Date of Birth
	Professional Qualification	
<b>Current Job</b>	Employer's name	
	Employer's address	
	Telephone No:	Contact person (Deputy / HR officer)
	Fax	E-mail
	Title	Number of years of experience with the present employer

**Legal representative of bidder**  
**(Name, position, signature and stamp)**

**PROFESSIONAL EXPERIENCE**

Summarize professional experience in reverse chronological order. Specify professional and management experience related to the bidding package

<b>From</b>	<b>To</b>	<b>Company/Project/Position/Related professional and management experience</b>

**Legal representative of bidder**  
**(Name, position, signature and stamp)**

**HISTORICAL CONTRACT NON-PERFORMANCE FOR THE SUPPLY OF GOODS  
NOT FULFILLED DUE TO FAULT OF THE CONTRACTOR IN THE PAST<sup>1</sup>**

Name of contractor: \_\_\_\_\_

Date: \_\_\_\_\_

Name of member of the consortium contractor (if any): \_\_\_\_\_

<b>Contracts for the supply of goods not fulfilled due to fault of the contractor in the past in accordance with Clause 2.1 Section 2 Chapter III</b>			
<input type="checkbox"/> No contract Supply of goods not fulfilled through bidder's fault as of January 01, [...] in accordance with Criterion 1 in the Evaluation Standards for Competence and Experience under Clause 2.1, Section 2, Chapter III.			
<input type="checkbox"/> There is a contract Supply of goods not fulfilled through bidder's fault as of January 01, 2022 in accordance with the Evaluation Standards for Competence and Experience under Clause 2.1 Section 2 of Chapter III.			
Year	Scope of work not fulfilled	Contract description	Total contract value (value, currency, exchange rate, equivalent value in VND)
		Contract Description: _____ Name of Investor: _____ Address: _____ Causes of non-fulfillment of the contract: _____	

**Legal representative of bidder  
(Name, position, signature and stamp)**

**Notes:**

<sup>1</sup> The Bidder must accurately and truthfully declare contracts for the supply of goods that were not fulfilled through fault of the Bidder in the past. In case Vietsovetro discovers that the bidder has a contract for the supply of goods that is not fulfilled due to fault of the bidder in the past which was not declared, the bidder is deemed to have committed fraud and its bid proposal shall be disqualified. For a consortium bidder, each member of the consortium must declare using this form.

**BIDDER'S HISTORICAL FINANCIAL PERFORMANCE<sup>1</sup>**

Bidder's name: \_\_\_\_\_

Date: \_\_\_\_\_

Name of Consortium member (if any): \_\_\_\_\_

Financial Data for Previous 03 Years <sup>2</sup> [VND/USD]:		
2023 ÷ 2025 or 2022 ÷ 2024		
Year 01 (2022)	Year 02 (2023)	Year 03 (2024)

## Information from balance sheet

Total assets			
Total liabilities			
Net worth			
Current assets			
Current liabilities			
Working capital			

**Information from Income Statement**

Total turnover			
Average annual turnover from business activities <sup>3</sup>			
Profits before taxes			
Profits after taxes			

Attached are copies of financial statements (balance sheets, including all related notes and income statements) for the last **03 years<sup>4</sup>**, as indicated above, complying with the following conditions:

\* All such documents reflect the financial situation of the legal entity or entities comprising the Bidder and not the Bidder's parent companies, subsidiaries or affiliates.

\* Historic financial statements must be audited in accordance with the applicable laws and regulations.

\* Historic financial statements must be complete, including all notes to the financial statements.

\* Historic financial statements must correspond to accounting periods already completed and audited. Attached with notarized copies one of following original documents:

- Tax finalization inspection report.
- Declaration form of self tax finalization report (VAT and CIT) confirmed by the Tax department/District tax department at the time of submitting the declaration form.
- Proper documentation in which the bidder has declared the electronic tax finalization.
- Confirmation in writing from tax department/ district tax department (confirmed the cumulative payment for full year) about complying paying tax duty.
- Audited report
- Other documents

**Legal representative of bidder**  
(Name, position, signature and stamp)

Notes:

<sup>1</sup> *In case of Consortium Bidder then each member of Consortium Bidder must declare according to this Form.*

<sup>2,4</sup> *The period stated here should be the same as the period indicated under Criterion 2.1 of Chapter III (Bid Evaluation Criteria).*

*In case Bidder has less than the number of years of establishment as required in ITB, the average annual turnover is calculated on the number of years that Bidder has been established.*

<sup>3</sup> *To determine average annual turnover from business activities, the Bidder will divide total turnover from business activities in years to number of years based on supplied information.*

**SCOPE OF WORK USING SUB-CONTRACTORS<sup>1</sup>**

<b>No.</b>	<b>Name of sub-contractor<sup>2</sup></b>	<b>Scope of work<sup>3</sup></b>	<b>Amount of work<sup>4</sup></b>	<b>Value estimated<sup>5</sup></b>	<b>Contract or agreement document with sub-contractor<sup>6</sup></b>
1.					
2.					
3.					
4.					
...					

**Legal representative of bidder**  
**(Name, position, signature and stamp)**

**Notes:**

<sup>1</sup> Applying this form in case of using sub-contractors.

<sup>2</sup> Bidder specifies the sub-contractor's names. In case at the moment at participating in bid, the sub-contractors have not yet been identified, bidders do not have to provide information in this column, but it should be declared in the column "Scope of work". After that, if bidder is being successful, since the sub-contractors mobilized for implementing the work have to be approved by the Vietsovpetro.

<sup>3</sup> Bidder specifies name and work description for the sub-contractor.

<sup>4</sup> Bidder specifies the scope of work for the sub-contractor.

<sup>5</sup> Bidder specifies the value of work percentage which the sub-contractor undertakes compared to the bidding price.

<sup>6</sup> Bidder specifies the contracts number or agreement documents, the bidder should submit the original or notarized copy of these documents.

**LIST OF SPECIALIZED SUB-CONTRACTORS<sup>1</sup>**

Bidder must provide the proof evidence which meets requirements prescribed at Point 2.3 Chapter III, Bid Proposal Evaluation criteria.

<b>No.</b>	<b>Name of specialized subcontractor<sup>2</sup></b>	<b>Scope of work<sup>3</sup></b>	<b>Amount of work<sup>4</sup></b>	<b>Percentage value estimated<sup>5</sup></b>	<b>Contract or agreement document with specialized sub-contractor<sup>6</sup></b>
1.					
2.					
3.					
4.					
...					

**Legal representative of bidder**  
**(Name, position, signature and stamp)**

**Notes:**

<sup>1</sup> Applying this form in case of using sub-contractor.

<sup>2</sup> Bidder specifies the specialized sub-contractor's name.

<sup>3</sup> Vietsovpetro specifies names and work description that are implemented by the specialized sub-contractor.

<sup>4</sup> Bidder specifies the scope of work assigned to the specialized sub-contractor.

<sup>5</sup> Bidder specifies the value of work in percentage which the specialized sub-contractor undertakes to perform, compared to the bidding price.

<sup>6</sup> Bidder specifies the contract numbers or agreement documents, the bidder should submit the original or notarized copy of these documents.

**LIST OF SUBSIDIARIES AND MEMBER COMPANIES DELIVERING WORK IN  
THE BID PACKAGE<sup>1</sup>**

No.	Name of subsidiary/ member company <sup>2</sup>	Scope of work <sup>3</sup>	Value (% out of bid value) <sup>4</sup>	Notes
1.				
2.				
...				

**Legal representative of bidder  
(Name, position, signature and stamp)**

**Notes:**

<sup>1</sup> In the case the contractor participating in bidding, being a parent company (for example, the Corporation), mobilizes its subsidiary or member company to deliver part of the work in the bid package, it must be specifically declared in this table. The evaluation of experience and competence of the bidder is based on the value and volume of work delivered by the parent company, subsidiary and member company in the bidding package. In case the bidder participating in bidding is not the parent company, this Form shall not apply.

<sup>2</sup> Specify the name of the subsidiary or member company.

<sup>3</sup> Specify the work delivered by the subsidiary or member company.

<sup>4</sup> Specify how many % the value of work delivered by the subsidiary or member company accounts for in the total bid proposal value.

**SUMMARY OF BIDDING PRICE**

<b>No.</b>	<b>Content</b>	<b>Bid price</b>
1.	Goods manufactured, processed outside Vietnam	(M <sub>1</sub> )
2.	Goods domestically manufactured, processed or goods manufactured, processed outside Vietnam, but already imported and being offered in Vietnam	(M <sub>2</sub> )
3.	Related services: <b>Not applicable</b>	(I)
	<b>Total bidding price</b> <b>(Transfer to Application for Biding form)</b>	<b>(M<sub>1</sub>) + (M<sub>2</sub>)</b> <b>+(I)</b>

**Legal representative of bidder**  
**(Name, position, signature and stamp)**

**BIDDING PRICE SCHEDULE OF GOODS MANUFACTURED,  
PROCESSED OUTSIDE VIETNAM**

(1)	(2)	(3)	(4)	(5)	(6)	(7)	(8)	(9)
Line item	Description of goods	Part number/ model of goods	MNF	CO	Unit	Required quantity	Unit price	Extended Price per line item (Col. 6x7)
1.	Goods 1							
2.	Goods 2							
	...							
<p><b>Total bidding price of goods including taxes, fees, charges (if any) arisen inside Vietnam and shall be taken into consideration exemption of import tax and VAT for imported goods from using List of exempted goods available for Vietsovpetro in Block 09-1</b></p> <p><b>(Transfer to the Summary of Bidding Price Form)</b></p> <p><b>Note:</b></p> <ul style="list-style-type: none"> <li>- Request to describe all the works and the Goods following requirements in Scope of supply indicated in Technical requirement (attached)</li> <li>- Request to breakdown value for each line item and for all items in Scope of supply</li> </ul>								<b>M1</b>

**Legal representative of bidder  
(Name, position, signature and stamp)**

**Notes:**

Col. (1), (2), (6) and (7): In accordance with List of goods stipulated in [Attachment 01: Scope of Supply in Part 4 – Appendices](#).

The bidder offers in Col. (3), (4), (8) and (9).

**For Vietnamese Bidders:** The Bidders are requested to offer price on delivery to **Vietsovpetro warehouse, Vung Tau City, S.R. Vietnam**, including taxes, fees, charges (if any) arisen inside Vietnam and shall be taken into consideration exemption of import tax and VAT for imported goods from using List of exempted goods available for Vietsovpetro in Block 09-1.

**For Foreign Bidders:** The Bidders are requested to offer price on delivery term: CFR Vietsovpetro Port, Vung Tau City, S.R. Vietnam, Incoterm 2020. Bidders must clearly state in the offered price, as followings:

- Bidder intends to use inland transportation to delivery the goods from any discharge port in Vietnam to Vietsovpetro port: Yes/No.

- If Bidder declares its attention to use inland transportation to deliver the goods from discharge port in Vietnam to Vietsovpetro port, Vietsovpetro will calculate and add FCWT into the offered price for comparison and evaluation.

- If Bidder declares NOT to use inland transportation to transport the goods to Vietsovpetro port, or makes no statement in this regard, Vietsovpetro will not calculate and add FCWT into the offered price for comparison and evaluation. Bidder shall acknowledge that, if any inland transportation is used during performance of Contract (if awarded to Bidder), Bidder will be subject to FCWT according to the applicable regulations of S.R. Vietnam. FCWT incurred will be deducted from payment by Vietsovpetro.

When participating in bidding, all bidders have to take responsibility of researching, calculating and offering sufficient tax, fees, charges (if any) in response to tax rates, expenses, fees at the time 28 days prior to the stipulated deadline for bid submission.

*In case the bidder announces the bidding price not including taxes, fees, charges then the Bid Proposal of the bidder will be rejected.*

**BIDDING PRICE SCHEDULE OF GOODS DOMESTICALLY MANUFACTURED,  
PROCESSED OR GOODS MANUFACTURED, PROCESSED OUTSIDE VIETNAM,  
BUT ALREADY IMPORTED AND BEING OFFERED IN VIETNAM**

(1)	(2)	(3)	(4)	(5)	(6)	(7)	(8)
Line item	Description of goods	Unit	Required quantity	Manufacturer, Country of origin, Part number, model of goods	Unit price	Extended Price per line item (Col. 4x6)	Taxes, fees, charges (if any)
1.	Goods 1					A1	T1
2.	Goods 2					A2	T2
...	...						
n	Goods n					An	Tn
<b>Total bidding price of goods not including taxes, fees, charges (if any)</b>						<b>A=A1+A2 + ...+An</b>	
<b>Total value of taxes, fees, charges (if any)</b>							<b>T=T1+T2 + ...+Tn</b>
<b>Total bidding price of goods including taxes, fees, charges (if any) (Transfer to the Summary of Bidding Price Form)</b>						<b>M<sub>2</sub>=A+T</b>	

**Legal representative of bidder  
(Name, position, signature and stamp)**

**Notes:**

*Detailed T1, T2 and Tn (type, calculation).*

*Col. (1), (2), (3) and (4): In accordance with List of Goods as stipulated in [Attachment 01: Scope of Supply in Part 4 – Appendices](#).*

*The bidder offers at Col. (5), (6), (7) and (8). The bidder offers unit price at col (6), including necessary expenses to supply goods in response to requirements of Vietsovetro, not including tax, fees, charges (if any) offered at col (8).*

*Col. (8) includes all tax, fees, charges (if any). When participating in bidding, bidders have to take responsibility of researching, calculating and offering sufficient tax, fees, charges (if any) in response to tax rates, expenses, fees at the time 28 days prior to the stipulated deadline for bid submission. In case the bidder announces the bidding price not including taxes, fees, charges then the Bid Proposal of the bidder will be rejected.*

**BIDDING PRICE SCHEDULE OF RELATED SERVICES**

(1)	(2)	(3)	(4)	(5)	(6)	(7)	(8)
No.	Description of Services	Required quantity	Unit	Place where services will be performed	Final completion date	Unit price	Extended price per Service (Col. 3x7)
<b>I.</b>	<b>Onshore technical service</b> .....						
<b>II.</b>	<b>Offshore technical service</b> .....						
<b>III.</b>	<b>Training (if any)</b> .....						
<b>IV.</b>	<b>Other services (if any)</b>						
1.							
2.							
<b>Total bidding price of related services not including taxes, fees, charges</b>							
<b>Taxes, fees, charges</b>							
<b>Total bidding price of related services including taxes, fees, charges (if any)</b> <b>(Transfer to the Summary of Bidding Price Form)</b>							<b>(I)</b>

**Legal representative of bidder**  
**(Name, position, signature and stamp)**

**Notes:**

*Col. (1), (2), (3), (4), (5) and (6): In accordance with Table of Related Services stipulated in Part 2 – The scope of supply's requirement.*

*The bidder offers Col. (7) and (8).*

*Foreign bidders have to clearly state that whether the offered price includes Foreign Contractor Withholding Tax (FCWT). If the offered price has not included, Vietsovetro will calculate and add FCWT into the offered price for comparison and evaluation.*

**BIDDING PRICE OF GOODS (OPTIONAL SCOPE)**  
**FOR GOODS MANUFACTURED, PROCESSED**  
**OUTSIDE VIETNAM**

(1)	(2)	(3)	(4)	(5)	(6)	(7)	(8)	(9)	(10)	(11)	(12)
Line item	Description of goods	Part number / model of goods	MNF	C/O	Unit	Required quantity	Unit price	Extended Price per line item (Col. 7x8)	Import tax	VAT	Total Price including all taxes
	<b>Priced list of recommended spares for 02 years' operation.</b> <i>(i.e.: as stated in Technical Requirement)</i> <i>Detailed list of spares part and prices shall be provided:</i>										
1.	.....								...	...	...
2.	.....								...	...	...
...	.....										
	<b>Total bidding price</b>							...			
	<b>Import tax</b>								...		
	<b>VAT</b>									...	
	<b>Total bidding price including all taxes</b> (Transfer to the Summary of Bidding Price Form)										<b>M1</b>

**Legal representative of bidder**  
**(Name, position, signature and stamp)**

**Notes:**

*Refer to Notes in Form 12A.*

**BIDDING PRICE OF GOODS (OPTIONAL SCOPE)**  
**FOR GOODS DOMESTICALLY MANUFACTURED, PROCESSED OR GOODS**  
**MANUFACTURED, PROCESSED OUTSIDE VIETNAM, BUT ALREADY**  
**IMPORTED AND BEING OFFERED IN VIETNAM**

(1)	(2)	(3)	(4)	(5)	(6)	(7)	(8)
Line item	Description of goods	Unit	Required quantity	Country of origin, Part number, model of goods	Unit price	Extended Price per line item (Col. 4x6)	Taxes, fees, charges (if any)
1.	Goods 1					A1	T1
2.	Goods 2					A2	T2
...	...						
n	Goods n					An	Tn
<b>Total bidding price of goods not including taxes, fees, charges (if any)</b>						<b>A=A1+A2+...+An</b>	
<b>Total value of taxes, fees, charges (if any)</b>							<b>T=T1+T2+...+Tn</b>
<b>Total bidding price of goods including taxes, fees, charges (if any)</b> (Transfer to the Summary of Bidding Price Form)						<b>M<sub>2</sub>=A+T</b>	

**Legal representative of bidder**  
(Name, position, signature and stamp)

**Notes:**

Refer to Notes in Form 12B.

DECLARATION OF PREFERENTIAL GOODS<sup>1</sup>

No.	Item	Origin <i>[name of country, origin, marks and numbers, model/PN, manufacturer]</i>	Goods with domestic production cost of 25% or higher		Domestic cost declaration	
			Yes	No	Form 15B	Form 15C
	(1)	(2)	(3)	(4)	(5)	(6)
1.	Goods 1		<input type="checkbox"/>	<input type="checkbox"/>	<input type="checkbox"/>	<input type="checkbox"/>
2.	Goods 2		<input type="checkbox"/>	<input type="checkbox"/>	<input type="checkbox"/>	<input type="checkbox"/>
...	...					
n	Goods n		<input type="checkbox"/>	<input type="checkbox"/>	<input type="checkbox"/>	<input type="checkbox"/>

**Legal representative of bidder**  
**(Name, position, signature and stamp)**

**Notes:**

(1) and (2): The bidder fills consistently with Form 15B or Form 15C.

(3) and (4): The bidder checks the correct box for each goods.

(5) and (6): For goods with a domestic production cost of 25% or higher, the contractor either declares the cost of domestic production using Form 15B (Declaration of cost of import) or Form 15C (Declaration of production cost in Vietnam).

**DECLARATION OF DOMESTIC PRODUCTION COSTS FOR  
PREFERENTIAL GOODS**

*(In the case of declaring cost of import)*

No.	Item	Offered price in Bid proposal	Taxes	Cost of import	Cost of domestic production	Cost of domestic production (%)
		(I)	(II)	(III)	$G^* = (I) - (II) - (III)$	$D(\%) = G^*/G$ where $G = (I) - (II)$
	(1)	(2)	(3)	(4)	(5)	(6)
1.	Goods 1					
2.	Goods 2					
...	...					
n	Goods n					

**Legal representative of bidder  
(Name, position, signature and stamp)**

**Notes:**

- (1) The bidder fills in the checked goods in column (3) and (5) of Form 15A.  
 (2) The bidder fills in the unit price offered (including all taxes, fees, charges (if any)).  
 (3) and (4) The bidder self-declares.  
 (5) and (6) The bidder fills.

**DECLARATION OF DOMESTIC PRODUCTION COST FOR PREFERENTIAL<sup>(1)</sup>***(In the case of declaring production costs in Vietnam)*

No.	Item	Offered price in Bid proposal	Taxes <sup>(2)</sup>	Cost of domestic production	Cost of domestic production (%)
		(I)	(II)	G*	$D(\%)=G^*/G$ where $G = (I) - (II)$
	(1)	(2)	(3)	(4)	(5)
1.	Goods 1				
2.	Goods 2				
...	...				
n	Goods n				

**Legal representative of bidder**  
**(Name, position, signature and stamp)**

**Notes:**

(1) The bidder fills in the checked goods in column (3) and (6) of Form 15A.

(2) The bidder fills in the unit price offered (including all taxes, fees, charges (if any)).

(3) and (4) The bidder self-declares.

(5) The bidder fills.

## **Part 2. TECHNICAL REQUIREMENTS**

### **Chapter V. Technical Requirements**

*(Refers to attachment in Part 4 – Appendices)*

### **Part 3. CONDITIONS OF CONTRACT AND CONTRACT FORMS**

Form 16. Letter of Proposal Acceptance and Contract Award

Form 17. Contract form

**LETTER OF PROPOSAL ACCEPTANCE AND CONTRACT AWARD**

\_\_\_\_\_, day \_\_\_\_ month \_\_\_\_ year \_\_\_\_

To: \_\_\_\_\_ [*name and address of awarded Contractor, hereinafter referred to as "Contractor"*]

Subj: Notification of Proposal Acceptance and Contract Award

Dear Sir/Madam,

In accordance with the Letter of Invitation to Tender (ITB No. ....) regarding tender process, we would like to notify that you are the tender winner for the items listed hereunder (scope of supply) based on the following basic terms and conditions:

- Scope of Supply: .....
- Total price: ..... – CFR Vietsovpetro port, Vungtau City, S.R. Vietnam
- Delivery time: ..... days from the date of Letter of Award / contract signing
- Payment condition: TT / LC

As soon as possible but not later than 07 working days from the date signing this Purchase Order, you should open the Performance Bond which is issued by banks / branches legally operated in Vietnam with amount **03% (three percent)** of Purchase Order and send to Vietsovpetro. The validity of the Guarantee is equal to the delivery time plus 60 calendar days.

Please acknowledge the receipt of this letter and send us your acceptance / comments as soon as possible but not later than 02 working days from the date of this letter.

Looking forwards to receiving your favorable reply.

**LEGAL REPRESENTATIVE OF THE EMPLOYER***[Full name, title, signature and stamp]*

**CONTRACT FORM****GENERAL CONDITIONS OF CONTRACT (GCC)****1. Definitions**

As used in this Contract:

- 1.1 Company means Vietsovpetro, as specified in the Purchase Order;
- 1.2 “Purchase Order” means the documented Agreement between the Company and the Contractor, including all attached appendices and documents; herein called PO;
- 1.3 “Contractor” means the bidder who has been awarded PO by the Company (either Independent or Consortium Contractor) and is specified in the PO;
- 1.4 “Subcontractor” means a person, or entity, Contractor whose name is proposed in the list of subcontractors by the Contractor in the Proposal or who carries out any part of work proposed by the Contractor in the Bid Proposal. Subcontractor enters into the PO with the Contractor to perform part of work, as specified in the Proposal and accepted by the Company;
- 1.5 “PO Documents” means the documents listed in the PO, including any amendments, addendums thereto;
- 1.6 “PO Price” means the total price as specified in the PO for supplying Goods (and Related Services). PO Price include all taxes, fees and charges (if any);
- 1.7 “Date” means calendar day; “Year” means 365 days;
- 1.8 “Goods” means all of the machinery, equipment, commodities, spare parts, raw materials, consumer goods, medical material used at medical facilities;
- 1.9 “Related Services” means the services such as warranty, maintenance, overhaul, repair, supply of spare parts and/or other after-sale services including training, technology transfer;
- 1.10 “Completion” means the fulfillment of the Related Services by the Contractor in accordance with the terms and conditions set forth in the Contract;
- 1.11 “The Project Site” means the place named in the PO.

**2. Order of precedence**

The documents forming the Contract is arranged in the following order of precedence:

- 2.1 PO, including all Appendix;
- 2.2 Letter of Proposal Acceptance and Contract Award;
- 2.3 Bidding Result Approval;
- 2.4 General Conditions of Contract (GCC);
- 2.5 Proposal and Clarifications (if any);
- 2.6 Invitation for Bid and Bulletins (if any);
- 2.7 Any other document listed in the PO.

**3. Governing law and Language**

The Contract shall be governed by and interpreted in accordance with the laws of the Socialist Republic of Vietnam. The Contract shall be written in English.

**4. Notice**

- 4.1 Any notice from one Party to another relating to the PO shall be conducted in writing, to addresses specified in the PO. The term “in writing” means communicated in written form with proof of receipt.
- 4.2 A notice from one Party shall be considered as effective from the date the other Party receives it or from the effective date as specified in the notice, whichever comes later.

## **5. Performance Bond**

- 5.1 Performance Bond shall be submitted to the Company no later than the date specified in Letter of Proposal Acceptance and Contract Award. Performance Bond shall be issued in one of following forms:
  - a) Submit a performance bond issued by a legally domestic bank or foreign bank’s branch established under Vietnamese law;
  - b) Submit the certificate of guarantee insurance from a domestic non-life insurance enterprise or a branch of a foreign non-life insurance enterprise established under Vietnamese law.  
The Performance Bond specified in Point a and b of this Clause is an unconditional guarantee (paid upon request), according to the form specified in the PO or another form approved by the Company.
- 5.2 Validity and formality is specified in the PO.
- 5.3. The Performance Bond will be paid to the Company to compensate for any loss arising from the Contractor's failure to fulfill their contractual obligations.
- 5.4 The return of Performance Bond is specified in the PO.

## **6. Subcontractor**

- 6.1 The Contractor is allowed to sign contracts with Subcontractors in the List of proposed subcontractors specified in the Contract to perform part of work stated in the Proposal. The use of subcontractors shall not relieve the Contractor from any of his obligations. The Contractor shall take full responsibilities for work load, quality, progress and other responsibilities for work performed by Subcontractors.  
The changing, supplement of subcontractors onto List of subcontractors or the change of subcontractor content stated in the Proposal shall be only conducted with reasonable grounds and Company’s approval.
- 6.2 Contractor is not allowed to use subcontractors for other work which are not stated in the Bid Proposal.
- 6.3 Other requirements for subcontractor are specified in the PO.

## **7. Settlement of Disputes**

- 7.1 The Company and the Contractor shall make every effort to resolve amicably by negotiation any disagreement or dispute arising between them.
- 7.2 If the dispute has not been resolved by such mutual negotiation within the specified duration in the PO from the date on which dispute arose, then either party may ask to commence arbitration under the dispute resolution mechanism, as specified in the PO.

## **8. Scope of Supply**

Goods (and Related Services) shall be supplied as specified in Appendix No. 01 – Scope of Supply, which is considered as an integral part of this PO, including types of goods (and Related Services) supplied by the Contractor and their unit prices.

## **9. Delivery Schedule of Goods, Completion Date of Related Services (if any) and Documentations**

Delivery Schedule of Goods, Completion Date of Related Services (if any) must be performed according to the provisions of the PO. The Contractor must provide invoice and other documents as described in the PO.

## **10. Contractor's Responsibilities**

Contractor shall supply all Goods (and Related Services) (if any) in accordance with the Scope of Supply in accordance with GCC Clause 8, and follow the Delivery Schedule of Goods (and Completion Date of Related Services), as per GCC Clause 9.

## **11. Type of Contract and Contract Price**

Type of contract: is specified in the PO.

Contract Price specified in the PO covers all expenses for complete supplying Goods (and Related Services) stated in the Price schedule of the PO.

## **12. Tax Adjustment**

12.1 The Contractor shall be responsible for all costs of taxes, fees and charges incurred until the goods are delivered to the Company.

12.2 In case the Contractor is eligible for tax, fee and charge exemption or reduction, the Company shall use its best efforts to enable the Contractor to apply tax, fee and charge exemption or reduction policies.

12.3 Tax adjustment are carried out in accordance with the PO.

## **13. Advance Payment**

13.1 The Company shall make advance payment to the Contractor with an amount stated in the Contract upon provision of Advance Payment Guarantee by the Contractor, with the value equal to the advance payment. The Advance Payment Guarantee shall be issued by a bank or credit organizations legally operating in Vietnam and shall remain effective until the advance payment has been repaid; the value of the Advance Payment Guarantee shall be progressively reduced by the amounts repaid by the Contractor. Interest shall not be applied on the advance payment.

13.2 The Contractor is to use the advance payment only for the purpose of executing the Contract. The Contractor has to prove that advance payment has been used for the right purpose by providing copies of invoices or other relevant documents to the Company. The Contractor shall be deprived of advance payment if advance payment is not used correctly.

## **14. Payment**

14.1 Payments are made in accordance with the PO.

14.2 The payment currency shall be VND/USD/EUR in accordance with the PO.

## **15. Copyright**

Copyright in all drawings, documents and records containing information and data submitted by the Contractor to the Company remains vested in the Contractor. Where such drawings, documents and records are provided to the Company directly or through the Contractor by a third party, copyright in such drawings, documents and records shall remain vested in that third party.

## **16. Use of documentations and information relating to Contract**

- 16.1. The Company and the Contractor shall keep confidential any documents, data or other information relating to the contract provided directly or indirectly by one party to the other party, and shall not disclose such documents, data or information to a third party without the prior written consent of the other party, whether such documents, data or information are provided before, during or after the fulfillment or termination of the contract. The Contractor may transfer to a subcontractor appropriate documents, data and information provided by the Company for the subcontractor to perform its work under the contract; in this case, the subcontractor shall have an undertaking to the Contractor to keep such documents, data or information confidential.
- 16.2. The Company shall not use the documents, data and other information received from the Contractor for any purpose other than the contract. The Contractor shall not use the documents, data and other information received from the Company for any purpose other than the performance of the contract.
- 16.3. The obligations of the Company and the Contractor specified in under GCC Sub-Clauses 16.1 and 16.2 shall not apply to information that:
- a) Information that the Company or Contractor needs to provide to the competent authority;
  - b) Information that has been or will be published through no fault of the Company or Contractor;
  - c) Information owned by one party at the time of publication and not previously provided directly or indirectly by the other party;
  - d) Information that a party lawfully receives from a third party that is not under an obligation to keep the information confidential.
- 16.4. The provisions of GCC Clause 16 shall not in any way modify any confidentiality commitments made by a party prior to the date of signing the contract relating to the provision of goods and services.
- 16.5. The provisions of GCC Clause 16 shall continue in effect after fulfillment or termination of the contract for any reason.

## **17. Technical Specifications and Standards**

Goods (and Related Services) supplied under this Contract shall conform to the technical specifications and standards mentioned in Appendix No. 01 - Scope of Supply; and when no applicable specification or standard is mentioned, the applicable specification or standard shall be equivalent or superior to the official standards currently applied in the Goods' country of origin.

## **18. Packing**

The Contractor shall provide such packing of the Goods as is required in the PO and is suitable with each type of transportation means during transit to their final destination. The packing shall be sufficient to prevent the Goods from damage or deterioration due to rough handling and other environmental impacts. Packing case size and weights shall take into consideration the conditions of transportation such as distance, type of transport mean, infrastructure, etc. from origin to specified destination.

## **19. Insurance**

Goods supplied in the Contract shall be fully insured to cover losses or damages occurred in production process, transportation, stocking and delivery as described in the PO.

## **20. Transportation and Incidental Services**

Conditions about Transportation and Incidental Services are specified in the PO.

## **21. Goods Inspections and Testing**

The Contractor must test and take inspection of Goods and related services relevant to the provisions of the Contract and bear all testing and inspection costs according to the provisions of the Contract.

## **22. Damages**

Damages are specified in the PO.

## **23. Warranty**

The Contractor warrants that all the Goods supplied under Contract are new, unused, and the quality is in accordance with manufacture standard, unless otherwise provided in the Contract. The Contractor further warrants that the Goods shall be free from defects that cause problems under normal use.

Warranty period and place for the Goods is specified in Article 9 of the PO.

## **24. Force Majeure**

24.1 For purposes of this Clause, “Force Majeure” means events beyond the control and foreseeability of the parties, such as wars, revolutions, fires, natural disaster, floods, epidemics, quarantine restrictions.

If a Force Majeure situation arises, the affected party shall promptly notify the other party in writing of such condition and the cause thereof. The affected party also has to give given by authorised organisation in the place of event.

During the Force Majeure, Contractor shall continue to perform its obligations under the Contract as far as is reasonably practical, and shall seek all reasonable alternative means for performance not prevented by the Force Majeure event. In this case, the Company shall consider reimbursing the Contractor necessary and reasonable additional and necessary costs beared by the Contractor.

24.2 Neither the party shall be liable for forfeiture of its Performance, liquidated damages, or if and to the extent that its delay in performance or other failure to perform its obligations under the Contract is the result of an event of Force Majeure.

In case dispute arising due to Force Majeure shall be resolved according to GCC Clause 7.

## **25. Amendment, Addendum of Contract**

25.1 Amendments to the Contract shall be applied in the following cases:

- (a) Changes in drawings, designs, or technical requirements, where Goods to be furnished under the Contract are to be specifically manufactured for the Company;
- (b) Changes in method of goods transportation or packing;
- (c) The place of delivery;
- (d) Changes of related services;
- (e) The schedule of delivery.

25.2. In case the amendment, addendum to the work content of the contract specified in Clause 25.1 GCC change the cost or implement time of any terms in the contract, price or delivery time and the completion date of the relevant service must be make corresponding adjustments and the two parties will amend the contract. The Contractor's request to adjust the contract's price, delivery time or completion date must be made within 28 days from the date the Contractor receives the Company's request to amend the scope of work.

25.3. In case the Contractor provides goods with a new version of the same manufacturer, the same origin, with technical requirements, configuration, parameters... equivalent or better than the

version that the Contractor proposed in their proposals, the Contractor must notify the Company in writing for the Company's consideration. In this case, based on usage needs, the Company could accept the Contractor's proposal provided that the unit price and other terms and conditions of the contract remain unchanged.

25.4. In case of performing related services that has not stated in the contract, the Company and Contractor will negotiate to ensure the unit price is consistent with the market price.

25.5. The Company and the Contractor will negotiate to sign a contract's amendment in case of amendments. All transactions during the implementation of the Contract are made in writing by the Parties and sent by post or by fax number to the registered address or fax number of each Party specified in the Contract and email to the email address according to the form in Appendix 04 (A, B) attached.

In case the Contractor's proposal is accepted by the Company and it makes the reduce of the contract price, the Company shall pay the Contractor with the rate that specified in the Contract to the price reduction value. And if it makes the increase of the contract price, the Company shall pay the Contractor the arising value.

## **26. Amendment in Delivery Schedule**

26.1. During the contract implementation time, in case of unfavorable conditions arise that prevents the Contractor or subcontractor from providing goods and performing related services as prescribed in Clause 9 GCC, The Contractor must promptly notify the Company in writing about the delay, reason, and duration of delay. Based on the Contractor's notice, the Company must quickly consider the situation and extend the contract. In case the Company agrees to extend the contract, the two parties will negotiate to sign amendments, supplement the contract.

26.2. Except the force majeure specified in Clause 24 GCC, if the Contractor delivers the Goods or completes related services lately, he is obliged to compensate the Company as prescribed in Clause 22 GCC.

## **27. Contract Termination**

27.1. Contract Termination due to faults:

a) The Company may terminate partial or all of the Contract without prejudice to other remedies for breach of contract by informing the Contractor by letter about the breaches in the contract in the following cases:

(i) The Contractor cannot deliver the goods or part of the goods within the shipment time as specified in the contract, or within the extension period as specified in Clause 26 GCC;

(ii) The Contractor does not perform any other obligations under the contract;

(iii) The Company show that the Contractor violated one of the prohibited acts specified in Article 16 of the Bidding Law during the bidding process or contract implementation;

b) In case the Company terminates partial or all of the contract according to Point a of this Clause, the Company may purchase similar goods and related services that have not been performed according to the terms and conditions and methods. The Contractor shall be responsible for compensating the Company for arising costs from purchasing of such similar goods and services. However, the Contractor must continue to perform the part of the contract that was not terminated.

27.2. Contract Termination due to insolvency

In case the Contractor goes bankruptcy or becomes insolvency, the Company may terminate the contract at any time by sending notice to the Contractor. In such case, the Contract shall terminate and the Contractor shall not be entitled to compensation provided that termination shall not fact or prejudice any rights of action or remedy of the Company at any time.

## **28. Patent indemnity**

28.1. The Contractor shall, subject to the Company's compliance with GCC Sub-Clause 28.2, indemnify and hold harmless the Company and its employees and officers from and against any and all suits, actions or administrative proceedings, claims, demands, losses, damages, costs, and expenses of any nature, including attorney's fees and expenses, which the Company may suffer as a result of any infringement or alleged infringement of any patent, utility model, registered design, trademark, copyright, or other intellectual property right registered or otherwise existing at the date of the contract by reason of:

- a) The installation of goods by the Contractor or the use of goods in Vietnam;
- b) The sale of the products produced by goods.

Such indemnity shall not cover any use of goods or any part thereof other than for the purpose indicated by or to be reasonably inferred from the contract, neither any infringement resulting from the use of goods or any part thereof, or any products produced thereby in association or combination with any other equipment, plant, or materials not supplied by the bidder, pursuant to the contract.

28.2. If any proceedings are brought or any claim is made against the Company arising out of the matters referred to in GCC Sub-Clause 28.1, the Company shall promptly give the Contractor a notice thereof, and the Contractor may at its own expense and in the Company's name conduct such proceedings or claim and any negotiations for the settlement of any such proceedings or claim.

28.3. If the Contractor fails to notify the Company within 28 days after receipt of such notice, that it intends to conduct any such proceedings or claim, then the Company shall be free to conduct the same on its own behalf.

28.4. The Company shall, at the Contractor's request, afford all available assistance to the Contractor in conducting such proceedings or claim, and shall be reimbursed by the Contractor for all reasonable expenses incurred in so doing.

28.5. The Company shall indemnify and hold harmless the Contractor and its employees, officers, and subcontractors from and against any and all suits, actions or administrative proceedings, claims, demands, losses, damages, costs, and expenses of any nature, including attorney's fees and expenses, which the Contractor may suffer as a result of any infringement or alleged infringement of any patent, utility model, registered design, trademark, copyright, or other intellectual property right registered or otherwise existing at the date of the contract arising out of or in connection with any design, data, drawing, specification, or other documents or materials provided or designed by or on behalf of the Company.

## **29. Change in laws and regulations**

Unless otherwise specified in the contract, if after the date of 28 days prior to deadline for submission of bids, any law or regulation is promulgated, abrogated, or changed in Vietnam that subsequently affects the Delivery Date and/or the contract Price, then such Delivery Date and/or Contract Price shall be correspondingly increased or decreased, to the extent that the Contractor has thereby been affected in the performance of any of its obligations under the contract. Notwithstanding the foregoing, such additional or reduced cost shall not be separately paid or credited if the same has already been accounted for in the price adjustment provisions where applicable, in accordance with GCC Clause 11.

## **30. Export restriction**

Any to provide deliveries or services, provided that the Contractor can declare to the satisfaction of the Company that it has completed all formalities in a timely manner, including applying for permits export restrictions which arise from trade regulations from a country supplying the goods or services, and which substantially impede the Contractor from meeting its obligations under the

contract, shall release the Contractor from the obligation, authorizations, and licenses necessary for the export of the goods or services under the terms of the contract. Termination of the contract on this basis shall be for the Company's convenience.

**PURCHASE ORDER**

\_\_\_\_\_, day \_\_\_\_ month \_\_\_\_ year \_\_\_\_

**FACSIMILE**

**PURCHASE ORDER No. ....**

<b>This Facsimile Transmission (Total ____ pages)</b>	
<b>Company:</b>	.....
<b>Country:</b>	.....
<b>Fax:</b>	.....
<b>From:</b>	<b>Vietsovpetro</b> <b>05 Le Loi Str, Vung Tau ward, HCM City, Vietnam</b>
<b>Subj.:</b>	<b>Provision of ..... (VSP's Inquiry No. ....)</b>

Dear Sir,

Thank you for your offer **provision of Air winch 5 ton for Tam Dao 02 (VSP's Inquiry No. VT 3657/25-KB)**. We are pleased to confirm this Purchase Order on the terms and conditions as follows:

This transaction is made between:

**VIETSOVPETRO**

**05 Le Loi Str, Vung Tau ward, HCM City, Vietnam**

Hereinafter referred to as the Buyer.

**AND**

.....

Hereinafter referred to as the Seller.

**ARTICLE 1: OBJECT**

The Seller agrees to sell and the Buyer agrees to buy ..... **(VSP's Inquiry No. ....)** hereinafter referred to as "Goods", with the quantity, specifications, scope of supply as described in Appendix No. 01 (in ... pages) which are considered as an integral part of this Purchase Order.

- All Goods are manufactured in .....
- The Goods will be used for Petroleum activities in Block ... of Vietsovpetro.

**ARTICLE 2: PRICE AND TOTAL VALUE**

- 2.1 The unit prices for the Goods are specified in the Appendix No. 01 of this Purchase Order.
- 2.2 The total value of this Purchase Order is **USD .....** - CFR Vietsovpetro Port, Vungtau City, S.R Vietnam – Incoterms 2020.  
**(In words: .....)**
- 2.3 The price as mentioned above is understood CFR – Vietsovpetro Port, Vungtau City, S.R. Vietnam – Incoterms 2020, not subject to any alteration and includes value of the Goods,

packing, marking, painting, assembling, testing, inspection, manufacturer's certificates, freight, export license if necessary, guarantee services if any etc... in accordance with terms and conditions of this Purchase Order as well as all duties levied in connection with the performance of this Purchase Order outside the Buyer's country.

### **ARTICLE 3: DELIVERY**

3.1 Delivery date: not later than **05 months** from the date of signing contract to the date that the Goods arrival at Vietsovpetro's port (included navigation and transportation time).

**Earlier shipment is allowed.**

**Partial shipment is allowed.**

**Transshipment and multimodal transport are allowed at Seller's care and account.**

3.2 Shipment to be made from ... port to Vietsovpetro Port, Vung Tau City, S.R. Vietnam on the term CFR Vietsovpetro Port, Vung Tau City, S.R. Vietnam – Incoterms 2020, except the otherwise stated in this Purchase Order.

The Seller shall be responsible for any extra transport, warehouse expenses, taxes and other charges incurred in connection with sending of Goods to the other port/wrong port (rather than Vietsovpetro port, Vung Tau City, S.R. Vietnam). The Buyer shall carry out all inland transportation from other port to Vietsovpetro port, Vung Tau City, S.R. Vietnam and these charges will be deducted from payment by the Buyer.

**For the mode of transport by sea or by air, in case the first import border gate (which is the port of discharge stated on the bill of lading or the customs declaration) is not Vietsovpetro port, Vungtau City, S.R. Vietnam (the port specified in the Purchase Order) and incur inland transportation to the port specified, the Seller will be subject to Foreign contractor withholding tax (FCWT) according to the current regulations of S.R. Vietnam. Any extra transport, warehouse expenses, other charges and FCWT incurred will be deducted from payment by the Buyer.**

In case the actual number of shipments exceeds the number specified in the Purchase Order, the Seller shall be responsible for all costs incurred for the shipments exceeding those stipulated in the Purchase Order, and these incurred costs shall be deducted from payment by the Buyer.

3.3 The Delivery Date is understood as: The date that Goods arrival at Vietsovpetro port (included navigation and transportation time).

The date of arrival mention here will following the date of arrival of the Goods at Vietsovpetro port that indicated in "Arrival Notice" of Vessel Agent.

3.4 The carrying vessel must have ISM certificate.

### **ARTICLE 4: NOTICE OF SHIPMENT AND DOCUMENTATION**

4.1 The Seller shall notify the Buyer by fax as soon as possible, but not later than 03 working days from the Bill of Lading date the following information regarding the shipment:

- Purchase Order Number.
- Name of Goods, quantity and value.
- Number of cases, gross weight, measurement.
- Bill of Lading number and its date.
- Name of vessel, nationality.
- Port of exit, ETD/ ETA.
- Address, telephone, fax of the shipping agent in Vietnam.
- Any other special instructions, which should call to the Buyer's attention.

The Seller shall be responsible for any losses, expenses which may be occurred due to incorrect information from the Seller to the Buyer.

4.2 Required shipping document for purchased goods.

4.2.1 By T/T:

Immediately but not later than 03 working days from the Bill of lading date the Seller shall send by Express courier or FEDEX or DHL at the Seller's expenses to "Vietsovpetro" – 105 Le Loi Str., Vung Tau City, S.R. Vietnam the following shipment documents:

1. **Clean on board Bill of Lading** evidencing shipment from ... port with destination Vietsovpetro Port, Vungtau City, S.R.Vietnam, consignee: Vietsovpetro 105 Le Loi Street, Vungtau City, S.R. Vietnam, marked "Freight prepaid": 02 Surrenders and 02 copies.

2. **Detailed Packing List** showing the content of each case or lot, gross and net weight: covering Goods as specified in Appendix No. 01 to this Purchase Order: 02 originals and 02 copies.

3. **Signed Commercial Invoice** issued by the Seller for the respective shipment value indicating CFR Vietsovpetro Port, Vungtau City, S.R.Vietnam, with itemized and total prices: 02 originals and 02 copies.

4. **Certificate of Origin** issued by the Chamber of Commerce/Competent Organisations in Manufacturer's / Exporter's country: 02 originals / electronic provided web-link to check and 02 copies.

5. **Certificate of Quality and Quantity** issued by manufacturer: 02 originals and 02 copies.

6. **Other Certificates** as stipulated in Technical Requirements: 02 originals and 02 copies.

7. **Certificates of Guarantee** issued by the Seller for the quality of Goods for the period of 12 months from the date of delivery: 02 originals and 02 copies.

8. **Export License** or **Letter of the Seller** stating that Export License is not necessary for export: 02 originals and 02 copies.

9. **Seller's fax** advising the shipment details (Invoice value, Bill of Lading date) to Vietsovpetro: 01 copy.

All the copies of the documents shall be legible, otherwise the photocopy of the original shall be furnished.

Seller shall be submit for Vendor data register list (VDRL) to Buyer for review/approval not later than 02 weeks from the date of Letter of Intent.

4.2.2 By L/C:

Immediately but not later than 05 working days from the Bill of lading date the Seller shall send by Express courier or FEDEX at the Seller's expenses to Vietsovpetro - 105 Le Loi Str., Vung Tau City, S.R. Vietnam the following shipment documents unless otherwise stated:

1. **Clean on board Bill of Lading** evidencing shipment from .... port with destination Vietsovpetro Port, Vungtau City, S.R.Vietnam, consignee: Vietsovpetro 105 Le Loi Street, Vungtau City, S.R. Vietnam, marked "Freight prepaid": 02 Surrenders and 02 copies.

2. **Detailed Packing List** showing the content of each case or lot, gross and net weight: covering Goods as specified in Appendix No. 01 to this Purchase Order: 02 originals and 02 copies.

3. **Signed Commercial Invoice** issued by the Seller for the respective shipment value indicating CFR Vietsovpetro Port, Vungtau City, S.R.Vietnam, with itemized and total prices: 02 originals and 02 copies.

4. **Certificate of Origin** issued by the Chamber of Commerce/Competent Organisations in Manufacturer's / Exporter's country: 02 originals / electronic provided web-link to check and 02 copies.

5. **Certificate of Quality and Quantity** issued by manufacturer: 02 originals and 02 copies.

6. **Other Certificates** as stipulated in Technical Requirements: 02 originals and 02 copies.
7. **Certificates of Guarantee** issued by the Seller for the quality of Goods for the period of 12 months from the date of delivery: 02 originals and 02 copies.
8. **Export License** or **Letter of the Seller** stating that Export License is not necessary for export: 02 originals and 02 copies.
9. **Seller's fax** advising the shipment details (Invoice value, Bill of Lading date) to Vietsovpetro: 01 copy.

All the copies of the documents shall be legible; otherwise the photocopy of the original shall be furnished.

- 4.3 If shipment to be made through a FIATA Freight Forwarder, under Through or Combined Transport Bill of Lading, the Seller shall have to send the Buyer by fax the copy of Local Bill of Lading of the last distance and inform the Buyer the name, address of the Transportation Agent in Vietnam.
- 4.4 Any storage demurrage or other charges due to non-receipt of shipping advice and/or shipping documents by the Buyer from the Seller or the Seller's agent as well as due to incorrect shipping document shall be at the Seller's account.
- 4.5 From the date of Letter of Award (LOA), The Seller must provide the Buyer with a regular report once a month on the first day of the month, showing the process of manufacturing, manufacturing, testing and supplying the Goods.

This report please send to email: .....@vietsov.com.vn and c/c: [..hq@vietsov.com.vn](mailto:..hq@vietsov.com.vn). The Seller must immediately report to Buyer the content of the report at least includes the following contents:

- a) Description of the work completed in the implementation stage;
- b) Highlighting delays or delays that are likely to occur and the causes of delays affecting production progress and providing measures to ensure progress;
- c) Change progress if any. During the implementation of the Purchase Order, all contacts of Seller send an official letter for VSP leader and send a copy by email: .....@vietsov.com.vn and c/c: [..hq@vietsov.com.vn](mailto:..hq@vietsov.com.vn).

- 4.6 Party B must ensure to provide all necessary documents as required in Article 4.2 of this Purchase Order when delivering goods to Party A. In case Party B delivers goods to Party A's warehouse in Vung Tau but does not have all the required documents, Party A agrees to allow Party B to temporarily store the goods at the warehouse to wait for the complete collection of documents at no extra charge for first 05 calendar days. From the 6th day onwards, Party B will have to pay Party A the storage cost of the shipment according to the current storage unit price of Party A that is applied to Party A's customers. This storage cost that will be deducted directly from the invoice for this Purchase Order or from any other payments of the Purchase Order that duly signed by both parties.

## **ARTICLE 5: PACKING**

- 5.1 Goods supplied under this Purchase Order shall be packed in accordance with international standard for export packing to ensure safety of Goods from damages and corrosion during transportation and suitable for crane operations and handling.
- 5.2 Before packing, all metal parts of Goods must be preserved with proper grease and wrapped in waterproof strong paper to ensure protection from any damage and corrosion during their transportation and storage in Buyer's country within the guarantee period.
- 5.3 The Seller shall provide for each package a detailed packing list in English indicating the Purchase Order number, description of items, gross and net weight. One copy of the packing list in a waterproof envelope shall be put into each case with the Goods, the other copy should be fastened to the outer side of the wooden case and shall be covered with a

metal plate nailed to the case. For steel cases, both copies of the packing list should be put into the cases.

- 5.4 The Seller shall be fully responsible for loss, damage of breakage of the Goods and/or rusting/corrosion resulting from defective or inadequate packing.

## ARTICLE 6: MARKING

- 6.1 Marking shall be done in three sides of each case containing Goods, on the two opposite sides and on the top and contain the following information in the English language:

Shipper:
Consignee: VIETSOVPETRO 105 Leloi Street, VungTau, S.R.VietNam
Purchase Order No.
Case No. /
Dimensions: Length x Width x Height in cm
Gross WEIGHT (KGS)
Net Weight (KGS)
Airport/Port of Destination

- 6.2 The marking must be clearly done by indelible paint and not less than 5 (five) cm high, unless restricted by the size of the case. Where necessary, the Seller shall conspicuously mark on the side of the case appropriate international marks according to the different characteristics, the special marking “Top”, “Bottom”, “Handle with care”, handling places for reloading.
- 6.3 For the oversized cases (more than 10M long), as well as for the case weighing 500 kgs and more, or if the height of the case exceeds one meter, the center of gravity shall be clearly shown with bright indelible paint with sign (+) on the end and side faces of the cases.
- 6.4 The case number shall be indicated by a fraction, the numerator shows the ordinal number of the cases, and the denominator indicates the overall quantity of the cases into which completely delivered Goods are packed.
- 6.5 The Seller shall be responsible for any kind of losses and/or damages of the Goods during loading and unloading as well as for its transportation as a consequence of improper or insufficient marking, as well as for any extra transportation and warehouse expenses, losses connected with misaddressed delivery of the Goods due to incomplete marking.

## ARTICLE 7: PAYMENT CONDITIONS

### By T/T:

- 7.1 One hundred percent (100%) of shipment value (after deducting the related fees as in Articles 3.2 above) shall be paid by Telegraphic Transfer to the Seller’s account within thirty (30) days from the date of the Certificate of quantity and condition issued by Independent Inspection Company at Buyer’s warehouse after receipt of the Goods and a full sets of documents above mentioned in Articles 4.
- 7.2 Transfer fee shall be on the Buyer’s account.
- 7.3 All the banking fees, including bank commission and other charges associated with the advising and corresponding bank shall be on the Seller’s account.
- 7.4 All charges in connection with the change of payment’s form/ conditions (whether occurred inside or outside S.R. Vietnam), due to Seller’s/Buyer’s request, shall be at the Seller’s/ Buyer’s account.
- 7.5 The Seller provides Seller’s bank account number.

**By L/C:**

7.6 As soon as possible, but not later than fifteen (15) days after the date of Seller's reconfirmation the Buyer will open through the Bank for Foreign Trade of Vietnam, Vung Tau Branch (Vietcombank Vung Tau) or other bank in Vietnam the Irrevocable and Unconfirmed Letter of Credit in favour of the Seller covering the total Purchase Order value with the content as per Appendix No. 03 which is to be considered as an integral part of this Purchase Order.

The validity of the Letter of Credit shall cover the Delivery Date plus 21 days.

7.7 Payment under this Letter of Credit shall be made for shipment and in the following installments to the Seller:

7.7.1 First Installment: 90% (Ninety percent) of the shipment value shall be made upon presentation of the following documents in English language by the Seller to the Bank:

1. **Clean on board Bill of Lading** evidencing shipment from .... port with destination Vietsovpetro Port, Vungtau City, S.R.Vietnam, consignee: Vietsovpetro 105 Le Loi Street, Vungtau City, S.R. Vietnam, marked "Freight prepaid": 02 Surrenders and 02 copies.

2. **Detailed Packing List** showing the content of each case or lot, gross and net weight: covering Goods as specified in Appendix No. 01 to this Purchase Order: 02 originals and 02 copies.

3. **Signed Commercial Invoice** issued by the Seller for the respective shipment value indicating CFR Vietsovpetro Port, Vungtau City, S.R.Vietnam, with itemized and total prices: 02 originals and 02 copies.

4. **Certificate of Origin** issued by the Chamber of Commerce/Competent Organisations in Manufacturer's / Exporter's country: 02 originals / electronic provided web-link to check and 02 copies.

5. **Certificate of Quality and Quantity** issued by manufacturer: 02 originals and 02 copies.

6. **Other Certificates** as stipulated in Technical Requirements: 02 originals and 02 copies.

7. **Certificates of Guarantee** issued by the Seller for the quality of Goods for the period of 12 months from the date of delivery: 02 originals and 02 copies.

8. **Export License** or **Letter of the Seller** stating that Export License is not necessary for export: 02 originals and 02 copies.

9. **Seller's fax** advising the shipment details (Invoice value, Bill of Lading date) to Vietsovpetro: 01 copy.

All the documents presented by the Seller to the Bank shall be duly certified by the Seller as correct, due and payable under the terms and conditions of the Letter of Credit.

Payment for incomplete delivery will not be allowed.

7.7.2 Second Installment: Ten percent (10%) of shipment value shall be payable against confirmation of the Buyer to the Bank within 30 days after the date of the Certificate of quantity and condition issued by Independent Inspection Company at Buyer's warehouse and Invoice. [Based on inland transportation costs, Vietsovpetro will calculate and deduct difference amount as stated at Point 3.2 – Article 3 \(if any\).](#)

7.8 The Letter of Credit shall be subject to the Uniform Customs and Practice for Documentary credit of International Chamber of Commerce (UCP No. 600), 2007 revision.

7.9 All the banking fees, including bank commission charges and other charges associated with the opening bank shall be on the Buyer's account.

7.10 All the banking fees, including bank commission charges and other charges associated with the advising and corresponding bank shall be on the Seller's account.

7.11 All charges in connection with the amendments of the Letter of Credit (whether occurred inside or outside S.R. Vietnam), due to Seller's/Buyer's request, shall be at the Seller's/Buyer's account.

- 7.12 All charges associated with any extension of the Letter of credit arising due to delay in delivery as stated in Article 3 of this Purchase Order shall be at the Seller's account.
- 7.13 The Letter of Credit is to be automatically cancelled within 15 days from the date of opening, if the Buyer does not receive the original Performance Bond in favour of the Buyer with the content as stated in Appendix No. 03 of this Purchase Order.

#### **ARTICLE 8: GOODS'S SURVEY**

- 8.1 The survey at Buyer's warehouse of the received Goods shall be made by Independent Inspection Company with issuing a Certificate of quantity and condition.
- 8.2 The Certificate of quantity and condition issued by Independent Inspection Company for the Goods supplied under this Purchase Order at Buyer's warehouse shall be legal document for Buyer to make claim to the Seller.

#### **ARTICLE 9: GUARANTEE**

- 9.1 The Seller guarantees that the Goods supplied under this Purchase Order shall be of the highest quality and designed standard as set in Manufacture's country for that type of Goods and shall meet current technological achievements as required, and shall be suitable for normal operation in tropical area condition regarding environment temperature up to 45 Deg. C, humidity up to 100%.
- 9.2 Proper material of high quality shall be used for manufacturing the Goods to be supplied under this Purchase Order, and the Seller guarantees that the Goods and its quality, quantity shall be fully in compliance with the technical specifications and scope of supply as mentioned in Article 1 to this Purchase Order.
- 9.3 The Seller guarantees normal operation of all Goods to be supplied under this Purchase Order ..... months from the date of delivery.
- 9.4 Should the Buyer reveal any defect within the guarantee period or if the quality of Goods supplied under this Purchase Order is not in compliance with terms and conditions of this Purchase Order and its appendices, the Buyer shall notify the Seller by fax of such defect. To substantiate the claims the Buyer shall submit to the Seller the official inspection report issued by Independent Inspection Company. The report of quality issued by Independent Inspection Company shall be legal document for Buyer to make claim to the Seller.
- Any claim relating to defects or non-conformity, which occurred during the guarantee period of the Goods with the technical conditions as stated in the Appendix No. 01 shall be submitted to the Seller not later than three months after expiration of the guarantee period.
- 9.5 The Seller shall inform the Buyer about the results of consideration of claim not later than 14 days after receipt of the Buyer's claim fax and the Seller shall eliminate the revealed defects, at his own expenses, at the Buyer's first request without any delay, but not later than 15 days after receipt of the Buyer's claim fax and/or replace the defective parts or the missing parts by the new ones of good quality on the condition CIF Vietsovetro port (or CIP Tan Son Nhat airport), S.R. Vietnam. All charge associated with return of the defective Goods to the Seller and delivery the new one to Buyer shall be at the Seller's account.
- 9.6 Should the Seller fail to eliminate the defects as claimed, or fail to deliver new Goods within the stipulated time in Article 9.5, the Buyer shall charge to the Seller the agreed and liquidated damages at the rate as per Article 10, the period of the above penalty shall be counted from the date of which the Seller receives the Buyer's official claim to the date of elimination of the defects or to the delivery date of the new replacement Goods minus 15 days or the Buyer shall have the right to eliminate such defects at the Seller's expenses without prejudice to its right in respect of the guarantee, and the Seller undertakes to defray at fist Buyer's request all actual expenses incurred in respect of such elimination and the agreed and liquidated damages at the rate 08% value of non-used Goods due to defect

found. Small defects not requiring the Seller's participation and/or permitting no delay will be eliminated by the Buyer and charged at normal costs to the Seller.

9.7 The guarantee period for replaced part shall be equal to that indicated in Article 9.3 and the guarantee period for Goods will be extended by the time during which it was not used due to defect found.

9.8 When the elimination and/or replacement is made and all related costs, expenses are settled, the claim is to be considered as finally settled.

All the claim amount, for which the Seller is to be responsible to the Buyer under this Purchase Order may be deducted by the Buyer from the payment of the Purchase Order value or may be covered by act of law or otherwise from the Seller to be agreed by both parties.

## **ARTICLE 10: DAMAGES**

10.1 The Seller must deliver goods as specified in Appendix No. 01 and by the date as stipulated in the Purchase Order. If delayed in delivery the Seller shall pay to the Buyer the agreed and liquidated damages as follows:

- Delay in the first four weeks: 1.00% of **shipment** value per week.
- Delay in each following week: 1.50% of **shipment** value per week.

When calculating the amount of the agreed and liquidated damages: One week is to be defined as 07 days with 04 days or more than 04 days to be considered as one week, 03 days and less will not be counted. The agreed and liquidated damages calculated on the value of the **shipment** until the total amount of agreed and liquidated damages for delay shall not exceed 08% of Purchase order value.

If the Seller delivers in number of shipments as specified in Appendix No. 01, then the delivery time of Purchase order shall be counted as the last portion's delivery. Goods of the previous portions are only recorded at the warehouse of the Buyer until the last portion of the Purchase order is delivered.

10.2 **If the Seller does not deliver the sufficient quantity and types of goods as prescribed in Appendix No. 01 of this Purchase order, in that case the Seller shall pay to the Buyer the agreed and liquidated damages an amount equal to 08% of that Goods.**

10.3 If the supplied goods do not conform to the quality as specified in Article 2 of the Purchase Order, the Buyer shall be entitled to refuse those Goods and payment of the Purchase Order, the Seller shall pay to the Buyer the agreed and liquidated damages as stipulated in Article 10.2. The Buyer shall be entitled to accept / not accept that the Seller will provide new goods to replace the defective ones.

10.4 Delay in delivery / insufficient quantity:

10.4.1 If delay in delivery exceeds 60 calendar days against the stipulated date as in Article 3.1 of this Purchase Order, except the Force majeure circumstances, the Buyer shall be entitled to:

a) Appoint a third party capable of providing goods/ goods with services. In that case, The Seller is responsible for signing a contract with that appointed party to continue performing the work.

Or:

b) Directly enter into contract with that third party buying goods / goods and services to continue performing the contract work. In that case, The Seller must pay the difference amount and other related costs and charges (if any).

Or:

- c) Unilaterally terminate the Purchase Order and in this case The Seller shall pay to the Buyer the agreed and liquidated damages an amount equal to 08% of the breached Purchase Order value.
- 10.4.2 If the Seller delayed in delivery of one portion more than 60 calendar days as specified in Article 3.1 of this Purchase Order except the Force majeure circumstances, the Buyer shall be entitled to:
- a) Appoint a third party capable of providing goods / goods with services. In that case, The Seller is responsible for signing a contract with the designated party to continue performing the work.
- Or
- b) Directly enter into contract with the third party buying goods / goods and services to continue performing the contract work. In that case, The Seller must pay the difference amount and other related costs and charges (if any).
- c) Unilaterally terminate the Purchase Order and in this case The Seller shall pay to the Buyer the agreed and liquidated damages an amount equal to 08% of the breached Purchase Order value.
- 10.5 The total amount of the agreed and liquidated damages should not exceed 08% the Purchase Order value.
- 10.6 **The amount of the agreed and liquidated damages stated in Article 10 of this Purchase Order is exclusive of VAT and import tax.**
- 10.7 The Buyer shall be entitled to:
- 1) Deduct the amount of agreed and liquidated damages from the payment for this Purchase Order or from any payment for other Purchase Order (if any) between both sides.
- 2) Request the Seller's issuing Bank to pay the amount equal to the Performance Bond's value;
- 3) The Buyer shall make a written request to the Seller for the amount of agreed and liquidated damages payment. In all cases, The Seller should have to make commitment to the Buyer for the agreed and liquidated damages payment.
- 10.8 Any compensation for damage (if any) other than the liquidated damages agreed above shall be made in accordance with the law of Vietnam.

## **ARTICLE 11: PERFORMANCE BOND**

- 11.1 As soon as possible within 07 (seven) calendar days from the date signing Purchase order (specified on page 01 of the contract), the Seller shall inform the Buyer by fax/telex of the issuance of the Performance Bond covering .....percent (.....%) of the Purchase Order amount, issued by the banks/branches legally operated in VietNam, acceptable to the Buyer, informing the number, date of issue and full content. In case the Performance Bond issued by the banks/branches legally operated in VietNam, the Seller shall ensure that the issuing Bank will send to the Buyer the original Performance Bond through Vietcombank Vung Tau Branch.

The content of the Performance Bond shall be in conformity with the Appendix No.1 of this Purchase Order

All costs relating to the Performance Bond shall be at Seller's account.

- 11.2 Should the Buyer not receive the valid, satisfactory Performance Bond within 30 days from the Purchase Order signing date, the Buyer has the right to cancel the Purchase Order at any time and withdraw the Bid Bond without recourse to the law court or to arbitration.
- 11.3 **Should the validity of the Performance Bond be required to be extended (due to delay or extension of Delivery Date of Goods) Seller shall immediately instruct the Issuing Bank to make amendment to the Performance Bond. At the same time, send Buyer the original**

Performance Bond that has been extended no later than 07 working days before the old Performance Bond expires. Such amendment shall be advised by the Issuing Bank to Buyer through Vietcombank Vung Tau Branch.

- 11.4 Should the Buyer make use of Performance Bond, it will immediately send to the Seller copy of declaration to the bank.

## **ARTICLE 12: FORCE-MAJEURE**

- 12.1 A force majeure means an event which occurs objectively and unpredictably and cannot be overcome though all necessary measures have been applied and all the permitted capabilities have been used i.e. war, rebel, army conflicts, embargo, natural calamities (floods, fires, quakes, tsunami ...), fire, diseases (Epidemic, Pandemic) published by WHO/Country, blockade announcements applied through Regional/National level by Government.
- 12.2 The Party who not be able to perform the obligations due to the directly impact of above force majeure shall notify to the other party immediately, including to furnish information, justification proving that the aforementioned force majeure are the main causes that effect of those obligations in the Contract, and evidences that are showing all actions has been made to remedy problem and reduce damages. Any delay in providing information, notice and justification up to 10 days upon the occurring of force majeure events could not be considered as exemption from the related Party's responsibility thereafter due to the force majeure.
- 12.3 The confirmation of Chamber of Commerce and Industry of Vietnam or authority department at the place where force majeure occurs is the evidence of happening force majeure and when it occurs.
- 12.4 If in the extent of performing obligations of one Party is hindered in whole or in part due to the above force majeure, then the duration of this Contract shall be extended to cover for the same period when force majeure occurs.
- 12.5 In case the force majeure lasts accumulated up to 02 months, each party reserves the right to terminate this Contract without any compensation to the other part.
- 12.6 The other event such as lack of material, electricity, personnel... is not considered as force majeure and not exempt from Party B's obligations in delivery or due to late delivery. Information from newspaper, website and other social media are for reference purpose only.

## **ARTICLE 13: LAW AND ARBITRATION**

- 13.1 This Purchase Order is governed and construed in accordance with the law of Vietnam.
- 13.2 Any disputes or discrepancies, which may arise out from this Purchase Order, shall be settled smoothly, amicably, basing on mutual benefit and mutual understanding.
- 13.3 All disputes arising out of or in relation to this Purchase Order shall be finally settled by Arbitration at the Vietnam International Arbitration Center (VIAC) in accordance with its rules of arbitration.
- The number of arbitrators shall be three.
- The place of the arbitration shall be Hanoi.
- The applicable law shall be the law of Vietnam.
- The language of arbitrator shall be Vietnamese.
- 13.4 Decision / award of the arbitration shall be final and binding upon both parties. The losing party will bear the arbitration fees.

## **ARTICLE 14: OTHER CONDITIONS**

- 14.1 Any amendment or supplement of this Purchase Order shall be valid only if they are made in writing and signed by both parties.
- 14.2 Neither party shall be entitled to transfer its rights and obligations under this Purchase Order to any third party without the prior consent in writing of the other party.
- 14.3 All taxes, duties, custom fees in connection with the execution of this Purchase Order levied inside S.R. Vietnam but exception of Seller's personnel income tax and FCWT shall be at Buyer's account.
- 14.4 This Purchase Order shall come into force from the date of Seller's reconfirmation, which should be received by the Buyer within 07 days of this Purchase Order date and the Purchase Order will be terminated upon fulfillment by both parties all their obligations as per stipulated in this Purchase Order.
- 14.5 This Purchase Order is made in English and consists of ... pages, including Appendices No. 01, 02, 03 and 04 which are considered as integral parts of this Purchase Order (Appendix No. 01: Scope of Supply and Price Table, Appendix No. 02: Performance Bond, Appendix No. 03: Letter Of Credit Specimen and Appendix No. 04 (A, B): Form of Purchase Order Transaction).
- 14.6 This Purchase Order is made in 05 originals of the same value, one of which retained by the Seller and three are retained by the Buyer.
- 14.7 Components of Purchase Order and legal order of precedence are as Clause 2 GCC.

We confirm that all of above mentioned terms and conditions of this Purchase Order are considered as terms and conditions of a Purchase Order signed by and between two our companies.

This is an operative instrument, no mail/airmail will be followed.

Best regards,

**FOR VIETSOVPETRO**

**Appendix No. 01 to the Purchase order No. ....**

**SCOPE OF SUPPLY AND PRICE TABLE**

*This appendix is based on requirements stated in the Invitation to Bid, Bid Proposal and agreements achieved during negotiations and finalizing Purchase Order including price (extended price) for **the whole package** and scope of supply. Price (extended price) for **the whole package** and scope of supply has included all tax, fees and charges (if any) in accordance with tax rate, fee and charge at the time of 28 days prior to bid closing time of bid proposal.*

**GOODS PRICE TABLE**

(1)	(2)	(3)	(4)	(5)	(6)	(7)	(8)	(9)
No.	Description	Unit	Qty	Model, Code, Part number	Manufacturer	Origin	Unit Price (USD)	Extended Price (USD) (Column 4x8)
1.	Item 1							M1
2.	Item 2							M2
	...							...
n	Item n							Mn
<b>Total price in CFR Vietsovpetro port (USD)</b>								<b>M=M1+M2+.. ..Mn</b>

**LEGAL REPRESENTATIVE OF  
THE BUYER**

*[Full name, title, signature and stamp]*

**LEGAL REPRESENTATIVE OF  
THE SELLER**

*[Full name, title, signature and stamp]*

**Appendix No. 02 to the Purchase order No. ....**

**PERFORMANCE BOND**

\_\_\_\_\_, day \_\_\_\_\_ month \_\_\_\_\_ year \_\_\_\_\_

TO: \_\_\_\_\_ [name of the Employer]  
(Hereinafter referred to as the "Employer")

With reference to Purchase Order No. \_\_\_\_\_ entitled \_\_\_\_\_ (hereinafter referred to as "the Purchase Order") entered into on the \_\_\_\_\_ by and between \_\_\_\_\_, having address at \_\_\_\_\_ (hereinafter referred to as "APPLICANT") and \_\_\_\_\_, we, \_\_\_\_\_, having registered office at \_\_\_\_\_ (hereinafter referred to as "GUARANTOR") hereby open in the favor of \_\_\_\_\_ (Hereinafter referred to as the "BENEFICIARY") an unconditional and irrevocable bank guarantee for the amount of \_\_\_\_\_ (In words: \_\_\_\_\_) (hereinafter referred to as "GUARANTEE").

This GUARANTEE is effective from the issuance date and shall remain valid, binding and in force until \_\_\_\_\_, hereinafter referred to as "the **Expiry Date**". For any extensions, renewals, or assignments of the Purchase Order beyond the time stated in this GUARANTEE, BENEFICIARY shall not be required to give notice to nor obtain the consent of GUARANTOR. This GUARANTEE would be extended upon written request of APPLICANT to cover the extension, renewal or assignment periods.

GUARANTOR hereby **unconditionally and irrevocably** guarantees to promptly pay BENEFICIARY an amount or amounts, specified by BENEFICIARY, up to the amount stated above, within 05 working days upon our receipt of BENEFICIARY's written demand stating that APPLICANT has failed to fulfill its performance obligation(s) under the Purchase Order.

After the Expiry date, this GUARANTEE shall automatically become null and void, whatsoever and irrespective of whether this GUARANTEE is returned to GUARANTOR or not.

The said guarantee amount shall be paid by GUARANTOR forthwith to BENEFICIARY notwithstanding any contestation or protest by APPLICANT or by GUARANTOR or by any third party, and irrespective of whether or not there is any dispute between APPLICANT and BENEFICIARY in respect of or relating to the Purchase Order or in respect of any other matter and irrespective of whether or not such said dispute, if any, has been settled, resolved, litigated, or adjudicated upon otherwise howsoever.

Neither alteration, variation, incorrect payment, extension in terms of the Purchase Order nor any forbearance of forgiveness in or in respect of any matter or thing concerning the Purchase Order on the part of BENEFICIARY shall in any way release GUARANTOR or APPLICANT or from any liabilities under this GUARANTEE.

Multiple demands under this Guarantee are allowed. In such event, the Guarantee Amount aforementioned shall automatically be reduced by the amount of each and any payment made by us under this Guarantee.

The Guarantee shall be governed by and construed in accordance with the laws of Vietnam. Any dispute arising out of or relating to this Guarantee shall be submitted to [the jurisdiction of competent People's Court of Vietnam in accordance with the governing law] / [arbitration by the Vietnam Arbitration Center international (VIAC) at the Vietnam Chamber of Commerce and Industry in accordance with its rules of arbitration].

This GUARANTEE is issued solely in 01 (one) bilingual original (Vietnamese and English) and is not transferrable. Should there be any inconsistency between the two languages of this GUARANTEE, the Vietnamese content shall prevail and be final.

**LEGAL REPRESENTATIVE OF THE BANK**

[Full name, title, signature and stamp]

**Appendix No. 03 to the Purchase order No. ....**

**LETTER OF CREDIT SPECIMEN**

**SUBJECT:**

**KIND OF L/C:** IRREVOCABLE UNCONFIRMED L/C, AT SIGHT.

**APPLICANT:** VIETSOVPETRO

(THE BUYER) 105 Le Loi Str., Vung Tau City, S.R. Vietnam

**BENEFICIARY:**

(THE SELLER)

**ADVISING BANK:**

**AMOUNT:** \_\_\_\_\_ USD

(In words: United State Dollars \_\_\_\_\_) – CFR Vietsovpetro port, Vung Tau City, S.R. Vietnam.

**VALIDITY:** The validity of the Letter of Credit shall cover the Delivery Date plus 21 days.

**PAYMENT CONDITIONS:**

Payment under this Letter of Credit shall be made for shipment and in the following installments:

I. First Installment: 90% (Ninety percent) of the shipment value shall be made upon presentation of the following documents in English language by the Seller to the Bank:

1. **Clean on board Bill of Lading** evidencing shipment from .... port with destination Vietsovpetro Port, Vungtau City, S.R.Vietnam, consignee: Vietsovpetro 105 Le Loi Street, Vungtau City, S.R. Vietnam, marked "Freight prepaid": 02 Surrenders and 02 copies.
2. **Detailed Packing List** showing the content of each case or lot, gross and net weight: covering Goods as specified in Appendix No. 01 to this Purchase Order: 02 originals and 02 copies.
3. **Signed Commercial Invoice** issued by the Seller for the respective shipment value indicating CFR Vietsovpetro Port, Vungtau City, S.R.Vietnam, with itemized and total prices: 02 originals and 02 copies.
4. **Certificate of Origin** issued by the Chamber of Commerce in Manufacturer's / Exporter's country: 02 originals / electronic provided web-link to check and 02 copies.
5. **Certificate of Quality and Quantity** issued by manufacturer: 02 originals and 02 copies.
6. **Other Certificates** as stipulated in Technical Requirements: 02 originals and 02 copies.
7. **Certificates of Guarantee** issued by the Seller for the quality of Goods for the period of 12 months from the date of delivery: 02 originals and 02 copies.
8. **Export License** or **Letter of the Seller** stating that Export License is not necessary for export: 02 originals and 02 copies.
9. **Seller's fax** advising the shipment details (Invoice value, Bill of Lading date) to Vietsovpetro: 01 copy.

II. Second Installment: Ten percent (10%) of shipment value shall be payable against confirmation of the Buyer to the Bank within 30 days after the date of the Certificate of quantity and condition issued by Independent Inspection Company at Buyer's warehouse.

The Letter of Credit shall be subject to the Uniform Customs and Practice for Documentary credit of International Chamber of Commerce (UCP No. 600), 2007 revision.

All the banking fees, including bank commission charges and other charges associated with the opening bank shall be on the Buyer's account.

All the banking fees, including bank commission charges and other charges associated with the advising and corresponding bank shall be on the Seller's account.

All charges in connection with the amendments of the Letter of Credit (whether occurred inside or outside S.R. Vietnam), due to Seller's/Buyer's request, shall be at the Seller's / Buyer's account.

All charges associated with any extension of the Letter of Credit arising due to delay in delivery as stated in Article 3 of this Purchase Order shall be at the Seller's account.

**COVERING:**

Scope of supply, specifications, Quantity and Prices are in accordance to Appendix No. 01 of Purchase Order No. \_\_\_\_\_

**SHIPMENT:**

Shipment to be made from \_\_\_\_\_ Port to Vietsovpetro Port, Vung Tau City, S.R. Vietnam on the terms of ..... – Incoterms 2020.

**Delivery date:**

- For the first shipment: as soon as possible and expected 04 weeks from the date of delivery notice of the Buyer;

- For the next shipments: as soon as possible and expected 15 days from the date of delivery notice of the Buyer

to the date that the Goods arrival at Vietsovpetro's port (included navigation and transportation time).

Earlier shipment is allowed.

Partial shipment is allowed.

Transshipment and multimodal transport are allowed at Seller's care and account.

The date of arrival mention here will following the date of arrival of the Goods at Vietsovpetro port, Vung Tau City, S.R. Vietnam that indicated in "Arrival Notice" of Vessel Agent.

**PACKING AND MARKING:** As per Purchase order No. \_\_ dated \_\_\_\_\_

**SPECIAL CONDITIONS:**

Agreed and liquidated damages for delay of delivery:

Shipment after above stated delivery date is allowed but not exceeds two months. For Bill of Lading dated after delivery date, Buyer's Bank is authorized to deduct the agreed and liquidated damages amount following the whole Purchase order be delay as follows:

- Delay in the first four weeks: 1.00% of shipment value per week.

- Delay in each following week: 1.50% of shipment value per week.

One week is to be defined as 07 days, 04 days or more than 04 days to be considered as one week, 03 days and less will not be counted.

Total agreed and liquidated damage amount does not exceed 08% of Purchase Order value.

The Letter of Credit is to be automatically cancelled within 15 days from the date of opening, if the Buyer does not receive the original Performance Bond in favour of the Buyer with the content as stated in Appendix No. 02 of this Purchase Order.

**Appendix No. 04A to the Purchase order No. ....**

**SAMPLE LETTER OF TRANSACTION PERFORMANCE PURCHASE ORDER**

Date month year 20...

To: Vietsovetro  
105 Le Loi – Thang Nhi Ward – Vung Tau City  
Fax: 84 254 3839 857  
Recipient: Tran Quoc Thang – Deputy General Director  
Copy: Nguyen Thi Van Anh – Manager of Commercial Department  
Email: [vspadmin@vietsov.com.vn](mailto:vspadmin@vietsov.com.vn), .....@vietsov.com.vn

(Write the transaction content of: Change of Goods / Services, progress, use of Quota, contents related to the Purchase Order value, payment .....)

**REPRESENTATIVE OF PARTY ...**

**(Sign and Stamp)**

**Appendix No. 04B to the Purchase order No. ....**

**SAMPLE LETTER OF TRANSACTION PERFORMANCE PURCHASE ORDER**

Date month year 20...

To: Vietsovpetro  
105 Le Loi – Thang Nhi Ward – Vung Tau City  
Fax: 84 254 3839 857  
Recipient: Vietsovpetro Commercial Department / Vietsovpetro Port & Logistics Division /  
**Drilling and Workover Division**  
Email: [vspadmin@vietsov.com.vn](mailto:vspadmin@vietsov.com.vn), .....@vietsov.com.vn

(Write the transaction content of: Notification of delivery, documentation of goods, notification of commencement of service / construction, information on personnel / equipment for service / construction ...

**REPRESENTATIVE OF PARTY....**

**(Sign and Stamp)**

## **ĐIỀU KIỆN CHUNG CỦA HỢP ĐỒNG (ĐKC)**

### **1. Định nghĩa**

Trong Hợp đồng này, các từ ngữ dưới đây được hiểu như sau:

- 1.1. “Chủ đầu tư” là **Liên doanh Việt – Nga Vietsovetro** được quy định tại **Hợp đồng**;
- 1.2. “Hợp đồng” là thỏa thuận giữa Chủ đầu tư và Nhà thầu, thể hiện bằng văn bản, được hai Bên ký kết, bao gồm cả các Phụ lục và các tài liệu kèm theo;
- 1.3. “Nhà thầu” là Nhà thầu trúng thầu (có thể là Nhà thầu độc lập hoặc liên danh) và được quy định tại **Hợp đồng**;
- 1.4. “Nhà thầu phụ” là Nhà thầu có tên trong danh sách các Nhà thầu phụ do Nhà thầu đề xuất trong **Hồ sơ dự thầu** và được Nhà thầu ký Hợp đồng để thực hiện dịch vụ liên quan;
- 1.5. “Tài liệu Hợp đồng” là các tài liệu được liệt kê trong Hợp đồng, bao gồm bất kỳ bản sửa đổi, bổ sung nào của Hợp đồng;
- 1.6. “Giá Hợp đồng” là tổng số tiền ghi trong Hợp đồng cho việc cung cấp hàng hóa và dịch vụ liên quan. Giá Hợp đồng đã bao gồm tất cả các chi phí về thuế, phí và lệ phí (nếu có);
- 1.7. “Ngày” là ngày dương lịch; “năm” là 365 ngày;
- 1.8. “Hàng hóa” bao gồm máy móc, thiết bị, nguyên liệu, nhiên liệu, vật liệu, vật tư, phụ tùng; hàng tiêu dùng; trang thiết bị y tế dùng cho các cơ sở y tế;
- 1.9. “Dịch vụ liên quan” bao gồm các dịch vụ như lắp đặt, duy tu, bảo dưỡng, sửa chữa ban đầu, bảo hiểm lắp đặt, bảo hiểm sửa chữa hoặc cung cấp các dịch vụ sau bán hàng khác như đào tạo, chuyển giao công nghệ, ...;
- 1.10. “Hoàn thành” là việc Nhà thầu hoàn tất các dịch vụ liên quan theo các điều khoản và điều kiện quy định tại Hợp đồng;
- 1.11. “Địa điểm dự án” là địa điểm được quy định tại **Hợp đồng**.

### **2. Tài liệu Hợp đồng và thứ tự ưu tiên**

- 2.1. Tất cả các tài liệu nêu tại Mục 2.2 ĐKC (bao gồm cả các phần của tài liệu) sẽ cấu thành Hợp đồng để tạo thành thể thống nhất, có tính tương hỗ, bổ sung và giải thích cho nhau.
- 2.2. Hợp đồng, các tài liệu và thứ tự ưu tiên pháp lý như sau:
  - a) Hợp đồng (kèm theo các Phụ lục Hợp đồng);
  - b) Biên bản thương thảo, hoàn thiện Hợp đồng;
  - c) Báo cáo phê duyệt kết quả lựa chọn nhà thầu;
  - d) Điều kiện chung của Hợp đồng;
  - đ) **Hồ sơ dự thầu** của Nhà thầu trúng thầu;
  - e) **Hồ sơ mời thầu** và các tài liệu sửa đổi **Hồ sơ mời thầu**.

### **3. Luật và ngôn ngữ**

Luật điều chỉnh Hợp đồng là luật Việt Nam, ngôn ngữ của Hợp đồng là tiếng Việt.

### **4. Thông báo**

- 4.1. Bất cứ thông báo nào của một Bên gửi cho Bên kia liên quan đến Hợp đồng phải được thể hiện bằng văn bản, theo địa chỉ quy định tại **Hợp đồng**. Thuật ngữ “bằng văn bản” có nghĩa là hình thức truyền đạt thông tin dưới dạng viết và có bằng chứng về việc tiếp nhận thông tin.
- 4.2. Thông báo của một Bên sẽ được coi là có hiệu lực kể từ ngày Bên kia nhận được hoặc theo ngày hiệu lực nêu trong thông báo, tùy theo ngày nào đến muộn hơn.

## **5. Bảo đảm thực hiện Hợp đồng**

5.1. Bảo đảm thực hiện Hợp đồng phải được nộp lên Chủ đầu tư không muộn hơn ngày quy định tại Thư chấp thuận **Hồ sơ dự thầu** và trao Hợp đồng. Bảo đảm thực hiện Hợp đồng được thực hiện bằng một trong các hình thức sau:

a) Nộp thư bảo lãnh của tổ chức tín dụng trong nước, chi nhánh ngân hàng nước ngoài được thành lập theo pháp luật Việt Nam;

b) Nộp giấy chứng nhận bảo hiểm bảo lãnh của doanh nghiệp bảo hiểm phi nhân thọ trong nước, chi nhánh doanh nghiệp bảo hiểm phi nhân thọ nước ngoài được thành lập theo pháp luật Việt Nam.

Bảo đảm thực hiện Hợp đồng theo quy định tại Điểm a và Điểm b Khoản này là bảo đảm không có điều kiện (trả tiền khi có yêu cầu), **theo mẫu quy định tại Phần 4** hoặc một mẫu khác được Chủ đầu tư chấp thuận.

c) Hình thức khác được Chủ đầu tư chấp thuận quy định tại **Hợp đồng**.

5.2. Bảo đảm thực hiện Hợp đồng có giá trị và hiệu lực quy định tại Hợp đồng.

5.3. Bảo đảm thực hiện Hợp đồng sẽ được trả cho Chủ đầu tư để bồi thường cho bất kỳ tổn thất nào phát sinh do Nhà thầu không hoàn thành các nghĩa vụ Hợp đồng.

5.4. Thời hạn hoàn trả bảo đảm thực hiện Hợp đồng theo quy định tại **Hợp đồng**.

## **6. Ký Hợp đồng thầu phụ**

6.1. Nhà thầu được ký kết Hợp đồng với các Nhà thầu phụ trong danh sách các Nhà thầu phụ quy định tại **Hợp đồng** để thực hiện dịch vụ liên quan nêu trong **Hồ sơ dự thầu**. Việc sử dụng Nhà thầu phụ sẽ không làm thay đổi các nghĩa vụ của Nhà thầu. Nhà thầu phải chịu trách nhiệm trước Chủ đầu tư về khối lượng, chất lượng, tiến độ và các nghĩa vụ khác đối với phần việc do Nhà thầu phụ thực hiện.

Việc thay thế, bổ sung Nhà thầu phụ trong danh sách các Nhà thầu phụ nêu trong **Hồ sơ dự thầu** hoặc thay đổi nội dung thầu phụ nêu trong **Hồ sơ dự thầu** chỉ được thực hiện khi được Chủ đầu tư chấp thuận; việc sử dụng Nhà thầu phụ phải phù hợp với nhu cầu của Nhà thầu trong thực hiện Hợp đồng, Nhà thầu phụ phải đáp ứng về năng lực, kinh nghiệm theo yêu cầu của Nhà thầu.

6.2. Nhà thầu có trách nhiệm thanh toán đầy đủ và đúng hạn cho Nhà thầu phụ theo các điều khoản thỏa thuận giữa Nhà thầu và Nhà thầu phụ.

## **7. Giải quyết tranh chấp**

7.1. Chủ đầu tư và Nhà thầu có trách nhiệm giải quyết các tranh chấp phát sinh giữa hai Bên thông qua thương lượng, hòa giải.

7.2. Nếu tranh chấp không thể giải quyết được bằng thương lượng, hòa giải trong thời gian quy định tại **Hợp đồng** kể từ ngày phát sinh tranh chấp thì bất kỳ Bên nào cũng đều có thể yêu cầu đưa việc tranh chấp ra giải quyết theo cơ chế được quy định tại Hợp đồng.

## **8. Phạm vi cung cấp**

Hàng hóa và dịch vụ liên quan phải được cung cấp theo quy định tại **Hợp đồng**.

## **9. Tiến độ giao hàng, lịch hoàn thành các dịch vụ liên quan (nếu có) và tài liệu chứng từ**

Tiến độ giao hàng và lịch hoàn thành các dịch vụ liên quan (nếu có) phải được thực hiện theo quy định tại **Hợp đồng**. Nhà thầu phải cung cấp các hóa đơn, chứng từ tài liệu khác theo quy định tại **Hợp đồng**.

## **10. Trách nhiệm của Nhà thầu**

Nhà thầu phải cung cấp toàn bộ hàng hóa và dịch vụ liên quan (nếu có) trong phạm vi cung cấp quy định tại Mục 8 ĐKC và theo tiến độ giao hàng, lịch hoàn thành các dịch vụ liên quan quy định tại Mục 9 ĐKC.

## **11. Loại Hợp đồng và giá Hợp đồng**

- 11.1. Loại Hợp đồng: theo quy định tại Hợp đồng.
- 11.2. Giá Hợp đồng quy định tại Hợp đồng là toàn bộ chi phí để hoàn thành việc cung cấp hàng hóa và dịch vụ liên quan của gói thầu nêu trong bảng giá Hợp đồng trên cơ sở bảo đảm tiến độ, chất lượng theo đúng yêu cầu của gói thầu.

## **12. Thuế, phí và lệ phí**

- 12.1. Nhà thầu chịu trách nhiệm đối với toàn bộ chi phí về thuế, phí và lệ phí phát sinh cho đến khi hàng hóa được giao cho Chủ đầu tư.
- 12.2. Trường hợp Nhà thầu thuộc đối tượng được miễn, giảm thuế, phí, lệ phí, Chủ đầu tư tạo điều kiện tối đa cho Nhà thầu áp dụng các chính sách miễn, giảm thuế, phí, lệ phí và được quy định tại Hợp đồng.
- 12.3. Việc điều chỉnh thuế thực hiện theo quy định tại **Hợp đồng**.

## **13. Tạm ứng**

- 13.1. Chủ đầu tư phải cấp cho Nhà thầu khoản tiền tạm ứng theo quy định tại **Hợp đồng**, sau khi Nhà thầu nộp Bảo lãnh tạm ứng tương đương với khoản tiền tạm ứng. Bảo lãnh tạm ứng phải được phát hành bởi một tổ chức tín dụng hoặc chi nhánh ngân hàng nước ngoài được thành lập theo pháp luật Việt Nam.
- 13.2. Nhà thầu chỉ được sử dụng tiền tạm ứng cho việc thực hiện Hợp đồng. Nhà thầu phải chứng minh rằng khoản tiền tạm ứng đã được sử dụng đúng mục đích, đúng đối tượng bằng cách nộp bản sao các hóa đơn chứng từ hoặc tài liệu liên quan cho Chủ đầu tư.

## **14. Thanh toán**

- 14.1. Yêu cầu thanh toán của Nhà thầu phải được gửi cho Chủ đầu tư bằng văn bản, kèm theo hóa đơn mô tả hàng hóa đã bàn giao và các dịch vụ liên quan đã thực hiện, cùng với chứng từ nộp theo quy định tại Điều 9 ĐKC và gửi yêu cầu thanh toán khi đã hoàn thành các nghĩa vụ khác quy định trong Hợp đồng.
- 14.2. Việc thanh toán thực hiện theo quy định tại **Hợp đồng**.
- 14.3. Đồng tiền thanh toán là VNĐ.

## **15. Quyền tác giả**

Quyền tác giả đối với tất cả các bản vẽ, tài liệu và hồ sơ chứa đựng thông tin và dữ liệu mà Nhà thầu đã nộp cho Chủ đầu tư vẫn thuộc về Nhà thầu. Trường hợp các bản vẽ, tài liệu và hồ sơ đó được cung cấp cho Chủ đầu tư một cách trực tiếp hoặc thông qua Nhà thầu bởi một Bên thứ ba thì quyền tác giả đối với các bản vẽ, tài liệu và hồ sơ thuộc về Bên thứ ba đó.

## **16. Sử dụng các tài liệu và thông tin liên quan đến Hợp đồng**

- 16.1. Chủ đầu tư và Nhà thầu phải bảo mật bất kỳ tài liệu, dữ liệu hoặc thông tin nào khác liên quan đến Hợp đồng do một Bên cung cấp trực tiếp hoặc gián tiếp cho Bên kia, không được tiết lộ tài liệu, dữ liệu hoặc thông tin đó cho Bên thứ ba nếu không có văn bản đồng ý của Bên kia cho dù tài liệu, dữ liệu hoặc thông tin đó được cung cấp trước, trong hoặc sau khi hoàn thành hoặc chấm dứt Hợp đồng. Nhà thầu có thể chuyển cho Nhà thầu phụ các tài liệu, dữ liệu và thông tin phù hợp do Chủ đầu tư cung cấp để Nhà thầu phụ thực hiện công việc

của mình theo Hợp đồng; trong trường hợp này, Nhà thầu phụ phải có cam kết với Nhà thầu về việc bảo mật các tài liệu, dữ liệu hoặc thông tin đó.

- 16.2. Chủ đầu tư không được sử dụng các tài liệu, dữ liệu và thông tin khác nhận được từ Nhà thầu cho bất kỳ mục đích nào khác không liên quan đến Hợp đồng. Nhà thầu không được sử dụng các tài liệu, dữ liệu và thông tin khác nhận được từ Chủ đầu tư cho bất kỳ mục đích nào khác không liên quan đến việc thực hiện Hợp đồng.
- 16.3. Nghĩa vụ của Chủ đầu tư và Nhà thầu quy định tại Mục 16.1 và Mục 16.2 ĐKC không áp dụng đối với các thông tin sau đây:
  - a) Thông tin mà Chủ đầu tư hoặc Nhà thầu cần cung cấp cho cấp có thẩm quyền;
  - b) Thông tin đã hoặc sẽ được công bố mà không phải do lỗi của Chủ đầu tư hoặc Nhà thầu;
  - c) Thông tin thuộc sở hữu của một Bên vào thời điểm công bố và trước đó không phải do Bên kia cung cấp trực tiếp hoặc gián tiếp;
  - d) Thông tin mà một Bên nhận được một cách hợp pháp từ một Bên thứ ba không có nghĩa vụ bảo mật thông tin.
- 16.4. Các quy định tại Mục 16 ĐKC không làm thay đổi bất kỳ cam kết bảo mật nào do một Bên đưa ra trước ngày ký Hợp đồng liên quan đến việc cung cấp hàng hóa, dịch vụ.
- 16.5. Các quy định tại Mục 16 ĐKC tiếp tục có hiệu lực sau khi hoàn thành hoặc chấm dứt Hợp đồng vì bất cứ lý do gì.

## **17. Thông số kỹ thuật và tiêu chuẩn**

Hàng hóa và các dịch vụ liên quan được cung cấp theo Hợp đồng sẽ phải tuân theo các thông số kỹ thuật và tiêu chuẩn [quy định tại Chương V](#); [nếu tại chương V không quy định](#) đến một thông số hay tiêu chuẩn nào có thể áp dụng thì phải tuân thủ theo thông số và tiêu chuẩn tương đương hoặc cao hơn tiêu chuẩn hiện hành tại quốc gia hoặc vùng lãnh thổ mà hàng hóa có xuất xứ.

## **18. Đóng gói hàng hóa**

- 18.1. Nhà thầu phải đóng gói hàng hóa đúng yêu cầu nhằm tránh hư hỏng trong quá trình vận chuyển đến địa điểm dự án theo quy định trong Hợp đồng. Trong quá trình vận chuyển, bao gói hàng hóa phải đủ chắc chắn để chịu được những va chạm mạnh, nhiệt độ quá cao hoặc quá thấp, trong nước mặn, nước mưa và ở ngoài trời. Kích thước và trọng lượng của mỗi kiện hàng phải tính đến điều kiện vận chuyển như khoảng cách, phương tiện vận chuyển, điều kiện cơ sở hạ tầng, ... từ nơi xuất hàng đến địa điểm dự án.
- 18.2. Việc đóng gói, ghi chú đối với hàng hóa, các giấy tờ bên trong và bên ngoài kiện hàng phải tuân thủ các yêu cầu cụ thể trong Hợp đồng, bao gồm cả các yêu cầu (nếu có) quy định ở **Hợp đồng** và các chỉ dẫn khác của Chủ đầu tư.

## **19. Bảo hiểm**

Trừ trường hợp có quy định khác tại Hợp đồng, hàng hóa cung cấp theo Hợp đồng phải được bảo hiểm đầy đủ cho các tổn thất, hư hại có thể xảy ra trong quá trình sản xuất hoặc tiếp nhận, vận chuyển, lưu kho và giao hàng theo quy định tại Hợp đồng.

## **20. Vận chuyển và các dịch vụ phát sinh**

- 20.1. Yêu cầu về vận chuyển hàng hóa và các yêu cầu khác quy định tại **Hợp đồng**.
- 20.2. Chủ đầu tư có thể yêu cầu Nhà thầu cung cấp một hoặc một số dịch vụ sau đây, bao gồm cả các dịch vụ (nếu có) theo quy định tại **Hợp đồng**:
  - a) Thực hiện việc lắp đặt hoặc giám sát việc lắp đặt tại hiện trường, chạy thử hàng hóa;
  - b) Cung cấp các dụng cụ cần thiết để lắp ráp, bảo dưỡng hàng hóa;

- c) Cung cấp tài liệu chi tiết hướng dẫn vận hành và bảo dưỡng cho từng loại hàng hóa;
  - d) Vận hành hoặc giám sát hoặc bảo dưỡng, sửa chữa hàng hóa trong khoảng thời gian đã được các Bên thỏa thuận, với điều kiện là dịch vụ này sẽ không miễn trừ cho Nhà thầu khỏi bất kỳ nghĩa vụ bảo hành nào theo Hợp đồng này;
  - đ) Hướng dẫn nhân sự của Chủ đầu tư về cách lắp đặt, chạy thử, vận hành, bảo dưỡng, sửa chữa hàng hóa.
- 20.3. Trường hợp phát sinh dịch vụ ngoài Hợp đồng, Chủ đầu tư và Nhà thầu thương thảo về chi phí thực hiện dịch vụ, bảo đảm không vượt quá mức giá mà Nhà thầu áp dụng cho dịch vụ tương tự trong các Hợp đồng khác.

## **21. Kiểm tra và thử nghiệm hàng hóa**

Nhà thầu phải tiến hành tất cả các thử nghiệm, kiểm tra đối với hàng hóa và dịch vụ liên quan theo quy định tại Hợp đồng và chịu toàn bộ chi phí thử nghiệm, kiểm tra theo quy định của Hợp đồng.

## **22. Phạt và bồi thường thiệt hại**

Phạt vi phạm Hợp đồng và bồi thường thiệt hại theo quy định tại **Hợp đồng**.

## **23. Bảo hành**

- 23.1. Nhà thầu bảo đảm cung cấp hàng hóa mới, chưa qua sử dụng theo đúng đề xuất đã nêu.
- 23.2. Nhà thầu bảo đảm hàng hóa không phát sinh khiếm khuyết do bất kỳ hành động hay sơ suất nào từ phía Nhà thầu hoặc do thiết kế, vật liệu hoặc kỹ thuật chế tạo khi hàng hóa được sử dụng bình thường trong các điều kiện phổ biến tại Việt Nam.
- 23.3. Thời hạn bảo hành và địa điểm áp dụng bảo hành quy định tại **Hợp đồng**.
- 23.4. Trường hợp phát hiện khiếm khuyết của hàng hóa, Chủ đầu tư kịp thời thông báo cho Nhà thầu, kèm theo tài liệu chứng minh. Chủ đầu tư tạo điều kiện cho Nhà thầu tiến hành kiểm tra các khiếm khuyết đó.
- 23.5. Sau khi nhận được thông báo của Chủ đầu tư về việc hàng hóa có khiếm khuyết, Nhà thầu phải kịp thời sửa chữa hoặc thay thế hàng hóa có khiếm khuyết trong thời hạn quy định tại **Hợp đồng** và chịu toàn bộ chi phí sửa chữa, thay thế.
- 23.6. Trường hợp đã được thông báo nhưng Nhà thầu không tiến hành sửa chữa khiếm khuyết của hàng hóa trong thời hạn quy định tại **Hợp đồng**, Chủ đầu tư có thể tự sửa chữa (nếu cần thiết). Nhà thầu phải chịu tất cả rủi ro và chi phí liên quan. Việc Chủ đầu tư tự sửa chữa khiếm khuyết của hàng hóa không ảnh hưởng đến các quyền khác của Chủ đầu tư đối với Nhà thầu theo Hợp đồng.

## **24. Bồi thường vi phạm sáng chế**

- 24.1. Với điều kiện là Chủ đầu tư tuân thủ Mục 24.2 ĐKC, Nhà thầu có nghĩa vụ bồi thường, bảo đảm Chủ đầu tư và nhân sự của Chủ đầu tư không bị tổn hại bởi bất kỳ vụ kiện tụng, thủ tục hành chính, khiếu nại, yêu cầu, tổn thất, thiệt hại, chi phí nào, bao gồm cả chi phí thuê luật sư vì có vi phạm hoặc cáo buộc vi phạm sáng chế, mẫu hữu ích, kiểu dáng công nghiệp, nhãn hiệu, quyền tác giả hoặc các quyền sở hữu trí tuệ khác đã đăng ký hoặc tồn tại vào ngày ký Hợp đồng mà các vi phạm hoặc cáo buộc vi phạm đó liên quan tới:

- a) Việc lắp đặt hàng hóa do Nhà thầu thực hiện hoặc việc sử dụng hàng hóa tại Việt Nam;
- b) Việc bán các sản phẩm được sản xuất từ hàng hóa.

Việc bồi thường nêu trên không áp dụng đối với các trường hợp sau: sử dụng hàng hóa hoặc bất kỳ phần nào của hàng hóa ngoài mục đích nêu trong Hợp đồng hoặc phát sinh hợp lý từ Hợp đồng; có hành vi vi phạm do sử dụng hàng hóa hoặc bất kỳ phần nào của hàng hóa, hay

bất kỳ sản phẩm nào được sản xuất từ hàng hóa có sự kết hợp các thiết bị, nhà xưởng hoặc vật tư khác không phải do Nhà thầu cung cấp theo Hợp đồng.

- 24.2. Trường hợp xảy ra kiện tụng hoặc khiếu nại đối với Chủ đầu tư liên quan tới các vấn đề quy định tại Mục 24.1 ĐKC, Chủ đầu tư có nghĩa vụ thông báo kịp thời cho Nhà thầu. Nhà thầu có thể nhân danh Chủ đầu tư giải quyết kiện tụng hoặc khiếu nại đó hoặc thương thảo để giải quyết kiện tụng hoặc khiếu nại đó và chịu trách nhiệm đối với các chi phí liên quan.
- 24.3. Trong vòng 28 ngày kể từ khi nhận được thông báo của Chủ đầu tư, trường hợp Nhà thầu không thông báo cho Chủ đầu tư về ý định giải quyết kiện tụng hay khiếu nại đó, Chủ đầu tư sẽ tự giải quyết.
- 24.4. Trường hợp được yêu cầu, Chủ đầu tư hỗ trợ Nhà thầu giải quyết vụ kiện tụng hay khiếu nại đó và sẽ được Nhà thầu hoàn trả mọi chi phí hợp lý phát sinh.
- 24.5. Chủ đầu tư có nghĩa vụ bồi thường, đảm bảo Nhà thầu, Nhà thầu phụ, nhân sự của Nhà thầu không bị tổn hại bởi bất kỳ vụ kiện tụng, thủ tục hành chính, khiếu nại, yêu cầu, tổn thất, thiệt hại, chi phí nào, bao gồm cả chi phí thuê luật sư vì có vi phạm hoặc cáo buộc vi phạm sáng chế, mẫu hữu ích, kiểu dáng công nghiệp, nhãn hiệu, quyền tác giả hoặc các quyền sở hữu trí tuệ khác đã đăng ký hoặc tồn tại vào ngày ký Hợp đồng mà các vi phạm hoặc cáo buộc vi phạm đó phát sinh từ hoặc liên quan đến bất kỳ thiết kế, dữ liệu, bản vẽ, thông số kỹ thuật hoặc các tài liệu và hồ sơ nào được cung cấp hoặc thiết kế bởi Chủ đầu tư hoặc thay mặt Chủ đầu tư.

## **25. Thay đổi liên quan đến pháp lý**

Trừ trường hợp có quy định khác tại Hợp đồng, kể từ 28 ngày trước ngày có thời điểm đóng thầu trở về sau, nếu có bất kỳ chính sách nào được ban hành, thay thế, sửa đổi hoặc tuyên bố hết hiệu lực tại Việt Nam gây ảnh hưởng đến ngày giao hàng và/hoặc giá Hợp đồng thì ngày giao hàng hoặc giá Hợp đồng phải được điều chỉnh tương ứng với mức độ ảnh hưởng của Nhà thầu khi thực hiện các nghĩa vụ theo Hợp đồng. Phần tăng hoặc giảm giá Hợp đồng không được thanh toán riêng hay ghi nhận khoản phải trả riêng nếu việc tăng hoặc giảm giá Hợp đồng này đã được quy định tại Mục 11 ĐKC.

## **26. Bất khả kháng**

- 26.1. Nhà thầu không bị tịch thu bảo lãnh thực hiện Hợp đồng, không phải chịu trách nhiệm bồi thường thiệt hại hay bị phạt hoặc bị chấm dứt Hợp đồng nếu rơi vào các sự kiện bất khả kháng gây cản trở tiến độ thực hiện Hợp đồng hoặc không thể thực hiện nghĩa vụ Hợp đồng.
- 26.2. Khi xảy ra sự việc bất khả kháng, việc một Bên không thực hiện được bất kỳ một nghĩa vụ nào của mình sẽ không bị coi là vi phạm hay phá vỡ Hợp đồng, với điều kiện Nhà thầu bị ảnh hưởng bởi vụ việc này: (a) đã tiến hành những biện pháp ngăn ngừa hợp lý, cẩn trọng và các biện pháp thay thế cần thiết, tất cả với mục đích thực hiện được những điều khoản và điều kiện của Hợp đồng này, và (b) phải tiếp tục thực hiện các nghĩa vụ của mình trong phạm vi Hợp đồng chừng nào việc thực hiện này còn hợp lý và thực tế.
- 26.3. Trong Hợp đồng này, bất khả kháng được hiểu là các sự kiện nằm ngoài tầm kiểm soát của các Bên và không thể lường trước, không thể tránh được và khiến cho việc thực hiện Hợp đồng là không khả thi mà nguyên nhân không phải do sơ suất hoặc thiếu chú ý của các Bên. Sự kiện bất khả kháng có thể bao gồm nhưng không giới hạn bởi chiến tranh, bạo loạn, đình công, hỏa hoạn, lũ lụt, dịch bệnh, cách ly do kiểm dịch hoặc các chính sách, quy định của Nhà nước.
- 26.4. Khi xảy ra sự kiện bất khả kháng, Nhà thầu bị ảnh hưởng bởi sự kiện bất khả kháng phải kịp thời thông báo bằng văn bản cho Bên kia về sự kiện đó và nguyên nhân gây ra sự kiện trong vòng 14 ngày kể từ ngày xảy ra sự kiện bất khả kháng. Đồng thời, chuyển cho Bên kia giấy xác nhận về sự kiện bất khả kháng đó được cấp bởi một tổ chức có thẩm quyền tại nơi xảy ra sự kiện bất khả kháng.

Nhà thầu bị ảnh hưởng bởi sự kiện bất khả kháng phải tiếp tục thực hiện các nghĩa vụ Hợp đồng theo hoàn cảnh thực tế cho phép và phải tìm mọi biện pháp hợp lý để hạn chế hậu quả của sự việc bất khả kháng.

- 26.5. Thời hạn mà một Bên phải hoàn thành một công việc theo Hợp đồng này được gia hạn thêm một khoảng thời gian bằng đúng thời gian Bên đó không thể thực hiện được công việc do sự kiện bất khả kháng gây ra.

## **27. Sửa đổi Hợp đồng**

- 27.1. Chủ đầu tư có thể yêu cầu Nhà thầu sửa đổi, bổ sung các nội dung sau đây trong phạm vi công việc của Hợp đồng:

- a) Thay đổi bản vẽ, thiết kế công nghệ hoặc yêu cầu kỹ thuật đối với trường hợp hàng hóa cung cấp theo Hợp đồng được đặt hàng sản xuất cho riêng Chủ đầu tư;
- b) Thay đổi phương thức vận chuyển hoặc đóng gói;
- c) Thay đổi địa điểm giao hàng;
- d) Thay đổi dịch vụ liên quan;
- đ) Điều chỉnh tiến độ thực hiện Hợp đồng theo quy định tại Mục 28 ĐKC.

- 27.2. Trường hợp việc sửa đổi, bổ sung các nội dung trong phạm vi công việc của Hợp đồng quy định tại Mục 27.1 ĐKC làm thay đổi chi phí hoặc thời gian thực hiện bất kỳ điều khoản nào trong Hợp đồng, giá Hợp đồng hoặc ngày giao hàng, ngày hoàn thành dịch vụ liên quan phải được điều chỉnh tương ứng và hai Bên tiến hành sửa đổi Hợp đồng. Yêu cầu của Nhà thầu về việc điều chỉnh giá Hợp đồng, ngày giao hàng hoặc ngày hoàn thành phải được tiến hành trong vòng 28 ngày, kể từ ngày Nhà thầu nhận được yêu cầu của Chủ đầu tư về việc sửa đổi, bổ sung nội dung công việc của Hợp đồng.

- 27.3. Trường hợp Nhà thầu cung cấp hàng hóa với phiên bản mới của cùng hãng sản xuất, có cùng xuất xứ, có tính năng kỹ thuật, cấu hình, thông số, ... tương đương hoặc tốt hơn phiên bản hàng hóa Nhà thầu đề xuất trong **Hồ sơ dự thầu** và đáp ứng yêu cầu **Hồ sơ mời thầu** thì Nhà thầu phải thông báo trước bằng văn bản cho Chủ đầu tư để Chủ đầu tư xem xét. Trong trường hợp này, căn cứ nhu cầu sử dụng, Chủ đầu tư có thể chấp thuận đề xuất của Nhà thầu với điều kiện là đơn giá và các điều kiện khác của Hợp đồng không thay đổi.

- 27.4. Trường hợp cần thực hiện các dịch vụ liên quan chưa nêu trong Hợp đồng, Chủ đầu tư và Nhà thầu tiến hành thương thảo, bảo đảm đơn giá phù hợp giá cả thị trường.

- 27.5. Chủ đầu tư và Nhà thầu sẽ tiến hành thương thảo để làm cơ sở ký kết văn bản sửa đổi Hợp đồng trong trường hợp sửa đổi Hợp đồng. Mọi giao dịch trong quá trình thực hiện Hợp đồng được các Bên thực hiện bằng văn bản và gửi theo đường bưu chính hoặc theo số Fax tới địa chỉ đăng ký hoặc số Fax của mỗi Bên ghi trong Hợp đồng và email đến địa chỉ email theo mẫu quy định tại **Hợp đồng**.

- 27.6. Trong thời gian thực hiện Hợp đồng, Nhà thầu có thể đề xuất giải pháp tiết kiệm chi phí bao gồm ít nhất các nội dung sau đây:

- a) Nội dung giải pháp, giải thích sự khác biệt so với các yêu cầu theo Hợp đồng đã ký kết;
- b) Phân tích toàn diện chi phí và lợi ích của giải pháp bao gồm mô tả và ước tính các chi phí (bao gồm cả chi phí vòng đời) có thể phát sinh cho Chủ đầu tư trong trường hợp chấp thuận đề xuất của Nhà thầu;
- c) Tác động của giải pháp đối với hiệu quả thực hiện Hợp đồng.

- 27.7. Chủ đầu tư có thể chấp thuận đề xuất của Nhà thầu nếu đề xuất này chứng minh được một trong các lợi ích dưới đây mà không làm ảnh hưởng đến các chức năng cần thiết của hàng hóa:

- a) Rút ngắn thời gian giao hàng;
- b) Giảm giá Hợp đồng hoặc chi phí vòng đời cho Chủ đầu tư;

- c) Nâng cao chất lượng, hiệu quả hoặc tính bền vững của hàng hóa trong Hợp đồng;
- d) Bất kỳ lợi ích nào khác cho Chủ đầu tư.

Trường hợp đề xuất của Nhà thầu được Chủ đầu tư chấp thuận và làm giảm giá Hợp đồng, Chủ đầu tư thanh toán cho Nhà thầu theo tỷ lệ quy định tại **Hợp đồng** đối với phần giá trị giảm giá Hợp đồng.

Trường hợp đề xuất của Nhà thầu được Chủ đầu tư chấp thuận và làm tăng giá Hợp đồng nhưng giảm chi phí vòng đời do tác động của các yếu tố quy định tại các điểm a, b, c và d khoản này, Chủ đầu tư thanh toán cho Nhà thầu theo phần giá trị tăng giá Hợp đồng.

## **28. Điều chỉnh tiến độ thực hiện Hợp đồng**

28.1. Trong quá trình thực hiện Hợp đồng, trường hợp phát sinh các điều kiện bất lợi, cản trở Nhà thầu hoặc Nhà thầu phụ trong việc cung cấp hàng hóa và lịch thực hiện các dịch vụ liên quan quy định tại Mục 9 ĐKC, Nhà thầu phải kịp thời thông báo bằng văn bản cho Chủ đầu tư về việc chậm tiến độ, nguyên nhân, khoảng thời gian chậm tiến độ. Trên cơ sở thông báo của Nhà thầu, Chủ đầu tư phải nhanh chóng đánh giá tình hình và có thể xem xét gia hạn Hợp đồng. Trường hợp Chủ đầu tư đồng ý gia hạn, các Bên tiến hành thương thảo để làm cơ sở ký kết Phụ lục sửa đổi, Bổ sung Hợp đồng.

28.2. Trừ trường hợp bất khả kháng quy định tại Mục 26 ĐKC, Nhà thầu giao hàng chậm hoặc hoàn thành dịch vụ liên quan chậm có nghĩa vụ bồi thường thiệt hại cho Chủ đầu tư theo quy định tại Mục 22 ĐKC.

## **29. Chấm dứt Hợp đồng**

29.1. Chấm dứt Hợp đồng do sai phạm

a) Chủ đầu tư có thể chấm dứt một phần hoặc toàn bộ Hợp đồng mà không gây tổn hại đến các biện pháp khắc phục vi phạm Hợp đồng khác bằng cách thông báo bằng văn bản cho Nhà thầu về sai phạm trong Hợp đồng trong các trường hợp sau:

(i) Nhà thầu không thể bàn giao hàng hóa hoặc một phần hàng hóa trong thời hạn quy định theo Hợp đồng, hoặc trong thời gian gia hạn theo quy định tại Mục 28 ĐKC;

(ii) Nhà thầu không thực hiện bất kỳ nghĩa vụ nào khác theo Hợp đồng;

(iii) Chủ đầu tư xác định Nhà thầu vi phạm một trong các hành vi bị cấm quy định tại **Hồ sơ mời thầu** trong quá trình đấu thầu hoặc thực hiện Hợp đồng;

b) Trường hợp Chủ đầu tư chấm dứt một phần hoặc toàn bộ Hợp đồng theo điểm a khoản này, Chủ đầu tư có thể mua sắm hàng hóa và dịch vụ liên quan tương tự như các hàng hóa và dịch vụ chưa được thực hiện theo các điều khoản và phương thức phù hợp. Nhà thầu phải chịu trách nhiệm bồi thường cho Chủ đầu tư các chi phí phụ trội phát sinh từ việc mua hàng hóa và dịch vụ tương tự đó. Tuy nhiên, Nhà thầu vẫn phải tiếp tục thực hiện phần Hợp đồng không bị chấm dứt.

29.2. Chấm dứt Hợp đồng do mất khả năng thanh toán

Trường hợp Nhà thầu phá sản hoặc mất khả năng thanh toán, Chủ đầu tư có thể chấm dứt Hợp đồng vào bất kỳ thời điểm nào bằng cách gửi thông báo cho Nhà thầu. Trong trường hợp đó, Hợp đồng sẽ chấm dứt và Nhà thầu không được bồi thường với điều kiện là việc chấm dứt Hợp đồng không gây tổn hại hoặc ảnh hưởng đến bất kỳ quyền khởi kiện hoặc biện pháp khắc phục của Chủ đầu tư trước đó hoặc sau đó.

## **30. Hạn chế xuất khẩu**

Trường hợp quốc gia, vùng lãnh thổ cung cấp hàng hóa, dịch vụ có các quy định thương mại dẫn tới việc hạn chế xuất khẩu, gây khó khăn cho Nhà thầu trong việc thực hiện các nghĩa vụ Hợp đồng, Nhà thầu không bắt buộc phải hoàn thành nghĩa vụ giao hàng, thực hiện dịch vụ với điều kiện là Nhà thầu cung cấp cho Chủ đầu tư các tài liệu chứng minh việc đã hoàn

thành tất cả các thủ tục xuất khẩu cần thiết, bao gồm cả xin giấy phép hoặc ủy quyền để xuất khẩu hàng hóa, dịch vụ theo Hợp đồng. Trong trường hợp này, Chủ đầu tư có thể chấm dứt Hợp đồng với Nhà thầu.

**CỘNG HÒA XÃ HỘI CHỦ NGHĨA VIỆT NAM**

Độc lập - Tự do - Hạnh phúc

\*\*\*

**HỢP ĐỒNG SỐ: .....**

*V/v: **Cung cấp ....., Lô 09-1 (Gói thầu VT-...../25-VTB)***

Căn cứ vào nhu cầu của Liên doanh Việt – Nga Vietsovpetro và khả năng cung cấp của Công ty...

Hôm nay, ngày \_\_\_\_ tháng \_\_\_\_ năm 2025, các Bên gồm:

**BÊN MUA: LIÊN DOANH VIỆT – NGA VIETSOVPETRO** – Gọi tắt là Bên A

Địa chỉ : 105 Lê Lợi, Phường Vũng Tàu, TP HCM

Điện thoại : 0254 3839 871 / 3839 872

Fax : 0254 3839 857

Tài khoản số : 008.1.00.000001.1

Tại Ngân hàng TMCP Ngoại thương Việt Nam, Chi nhánh Vũng Tàu

Mã số thuế : 3500102414

Đại diện **Ông Trần Quốc Thắng – Phó tổng giám đốc làm đại diện**

(Theo Giấy ủy quyền của Tổng giám đốc Vietsovpetro số .....

**BÊN BÁN: CÔNG TY .....** – Gọi tắt là Bên B

Địa chỉ :

Điện thoại :

Fax :

Tài khoản số :

Mã số thuế :

Đại diện :

Hai Bên thỏa thuận ký kết hợp đồng với các điều khoản như sau:

**Điều 1: Đối tượng hợp đồng**

Bên A đồng ý mua và Bên B đồng ý bán “..... – **Lô 09-1**“ (sau đây gọi tắt là “Hàng hóa”) với chủng loại, số lượng, đặc điểm kỹ thuật, đơn giá, giá trị hàng hóa theo Phụ lục số 01 của hợp đồng và là một phần thống nhất và không tách rời của hợp đồng này.

Hàng hóa của hợp đồng được Vietsovpetro sử dụng cho hoạt động dầu khí tại **Lô 09-1**.

**Điều 2: Giá trị hợp đồng**

- *Đối với các hàng hóa được sản xuất, gia công trong nước hoặc hàng hóa được sản xuất, gia công ở ngoài nước nhưng đã nhập khẩu vào Việt Nam:*

2.1 **Tổng giá trị Hợp đồng:** \_\_\_\_\_ VNĐ

**Bằng chữ:** \_\_\_\_\_

**Trong đó: - Tiền hàng hóa:** \_\_\_\_\_ VNĐ

**- Tiền thuế GTGT:** \_\_\_\_\_ VNĐ

2.2 Tiền thuế GTGT ghi ở Điều 2.1 là tiền thuế GTGT tạm tính. Thuế GTGT thực tế sẽ được thanh toán theo luật thuế hiện hành.

2.3 Giá trị hợp đồng nêu trên được tính trên cơ sở giao hàng tại kho Vietsovpetro tại Thành phố Vũng Tàu, bao gồm giá trị hàng hóa và các loại phí do Bên B chi trả như phí vận chuyển, đóng gói, bốc xếp lên phương tiện vận chuyển, giám định hàng hóa trước khi gửi hàng, ... và các chi phí khác liên quan đến việc thực hiện Hợp đồng này. Giá trên là giá cố định và không thay đổi trong suốt thời gian Hợp đồng có hiệu lực.

- Đối với các hàng hóa được sản xuất, gia công ở ngoài nước và Bên B sử dụng quota của Bên A để nhập khẩu trực tiếp hàng hóa:

2.4 Tổng giá trị Hợp đồng: \_\_\_\_\_ VNĐ

Bằng chữ: \_\_\_\_\_

Giá trị hợp đồng trên không bao gồm thuế nhập khẩu, không bao gồm thuế GTGT của giá trị hàng hóa nhập khẩu ghi trên Tờ khai Hải quan nhưng đã bao gồm các loại thuế, phí, lệ phí phát sinh trong lãnh thổ Việt Nam. Thuế nhập khẩu và thuế GTGT trên được miễn theo Hiệp định liên Chính phủ cho hàng hóa Lô 09-1. Bên B được sử dụng Hạn mức nhập khẩu Lô 09-1 của Bên A để làm thủ tục nhập khẩu hàng hóa và miễn thuế theo Hiệp định.

2.5 Giá trị Hợp đồng nêu trên được tính trên cơ sở giao hàng tại kho Vietsovpetro tại Thành phố Vũng Tàu, bao gồm giá trị hàng hóa và các loại phí do Bên B chi trả như phí vận chuyển, đóng gói, bốc xếp lên phương tiện vận chuyển, giám định hàng hóa trước khi gửi hàng, ... và các chi phí khác liên quan đến việc thực hiện Hợp đồng này (không bao gồm thuế nhập khẩu, không bao gồm thuế GTGT của giá trị hàng hóa nhập khẩu ghi trên Tờ khai Hải quan). Giá trên là giá cố định và không thay đổi trong suốt thời gian Hợp đồng có hiệu lực.

### **Điều 3: Quy cách, số lượng, chất lượng hàng hóa**

3.1 Quy cách, số lượng, chất lượng, chủng loại, ký mã hiệu, hãng sản xuất, nước sản xuất, năm sản xuất và những thông số khác của hàng hóa do Bên B cung cấp phải phù hợp với quy định nêu trong Phụ lục số 01 của hợp đồng này. Hàng hóa mới 100%, chưa qua sử dụng và trong tình trạng sử dụng tốt, được sản xuất năm .....

3.2 Hồ sơ kèm theo hàng hóa gồm:

- 02 Hóa đơn thuế GTGT (02 bản gốc);
- Chứng chỉ xuất xứ (C/O) do phòng Thương mại hoặc cơ quan có thẩm quyền của nước sản xuất hoặc nước xuất khẩu hàng cấp (Bản gốc / Bản điện tử có kèm đường link để kiểm tra);
- Chứng chỉ số lượng và chất lượng (C/Q) do nhà sản xuất cấp (Bản gốc);
- Các chứng chỉ khác (theo các yêu cầu kỹ thuật của HSMT) (Bản gốc);
- Chứng chỉ bảo hành của Bên B bảo hành ..... kể từ ngày giao hàng (Bản gốc);
- Tờ khai hải quan hàng hóa nhập khẩu (Bản copy);
- Tài liệu kỹ thuật của hàng hóa (nếu có).

Hồ sơ mời thầu của Bên A và Hồ sơ dự thầu của Bên B cho gói thầu số ..... là tài liệu tham chiếu về kỹ thuật cho hàng hóa của hợp đồng này.

### **Điều 4: Giao nhận và kiểm tra, giám định hàng hóa**

4.1 Hàng hóa được giao phải phù hợp với yêu cầu quy định tại Điều 1 và Điều 3 của hợp đồng này trong thời hạn là **05 tháng** tính từ ngày ký hợp đồng đến ngày giao hàng tại kho của Bên A. Ngày giao hàng của hợp đồng này được ghi trong Biên bản giao nhận hàng do đại diện hai bên ký như quy định tại mục 4.7 dưới đây.

*Tham chiếu gói thầu của hợp đồng này, Vietsovpetro đã đánh giá và lựa chọn nhà thầu cung cấp trọn gói hoặc theo nhóm, thời gian giao hàng trên áp dụng cho trọn gói hoặc theo nhóm. Nếu nhà thầu không giao hoặc giao chậm bất kỳ phần hàng nào sẽ bị tính phạt giao chậm theo giá trọn gói hoặc theo nhóm.*

Định kỳ 02 tuần/lần (trước ngày 15 và 30 hàng tháng), Bên B có trách nhiệm thông báo bằng văn bản cho Bên A cập nhật tình hình đặt hàng, tiến độ sản xuất và kế hoạch giao hàng của hợp đồng. Trong quá trình thực hiện hợp đồng, nếu Bên B gặp vướng mắc liên quan đến việc giao hàng thì Bên B cần khẩn trương thông báo cho Bên A bằng văn bản để hai bên phối hợp xem xét xử lý nhằm đảm bảo việc cung cấp hàng hóa cho Bên A theo đúng chất lượng và tiến độ của hợp đồng.

- 4.2 (Đối với trường hợp nhà thầu sử dụng quota của VSP để nhập khẩu hàng hóa) Bên B tự chịu trách nhiệm làm thủ tục Hải quan cho hàng hóa nhập khẩu. Bên A cho phép Bên B được sử dụng hạn mức nhập khẩu của Bên A đã đăng ký tại Hải quan Vũng Tàu để làm thủ tục nhập khẩu và hỗ trợ Bên B về mặt giấy tờ trong việc sử dụng hạn mức nhập khẩu của Bên A cho lô hàng nhập khẩu của Hợp đồng này để Bên B xin miễn thuế nhập khẩu và thuế giá trị gia tăng của giá trị hàng hóa nhập khẩu ghi trên Tờ khai Hải quan theo quy định cho Liên doanh Việt – Nga Vietsovpetro.
- 4.3 (Đối với trường hợp nhà thầu sử dụng quota của VSP để nhập khẩu hàng hóa) Để thuận tiện cho việc thông quan, làm các thủ tục miễn thuế nhập khẩu, hàng hóa Bên B nên nhập về cảng Vũng Tàu. Bên A không chịu trách nhiệm trả tiền thuế cho Bên B trong trường hợp nếu Bên B nhập hàng hóa về cảng khác mà không làm được thủ tục miễn thuế hoặc Bên B không sử dụng hạn mức nhập khẩu của Bên A.
- 4.3 Hàng hóa được giao không quá ... **lần** vào kho của Bên A (kho của Xí nghiệp Dịch vụ cảng và Cung ứng vật tư thiết bị, LD Việt- Nga Vietsovpetro tại số 67, đường 30/4, phường Thắng Nhất, thành phố Vũng Tàu). Bên B cam kết giao hàng đúng số lần quy định  
Dỡ hàng từ phương tiện của bên B do Bên A đảm nhận bằng phương tiện, nhân lực và chi phí của mình.
- 4.5 Trong vòng 02 ngày trước khi giao hàng, Bên B phải thông báo bằng văn bản cho Bên A biết về số lượng, quy cách đóng gói hàng hóa để Bên A bố trí nhân lực và phương tiện bốc dỡ.
- 4.6 Người của Bên B đến giao hàng phải có giấy giới thiệu của người đại diện ký Hợp đồng của Bên B.
- 4.7 Đại diện của Liên doanh Việt – Nga Vietsovpetro (là Xí nghiệp Dịch vụ và Đơn vị đặt hàng) và đại diện của Bên B tham gia giao nhận, kiểm tra hàng hóa của hợp đồng này và lập Biên bản giao nhận hàng (theo Phụ lục số 02 của hợp đồng này) sẽ ghi rõ số lượng, tình trạng, các hồ sơ giao kèm theo hàng hóa. Biên bản giao nhận hàng phải được Lãnh đạo Xí nghiệp Dịch vụ và Lãnh đạo Đơn vị đặt hàng phê duyệt. Biên bản giao nhận hàng là căn cứ để Bên A thanh toán cho Bên B.
- 4.8 Trong trường hợp cần thiết, bằng chi phí của mình, Bên A (giao cho Xí nghiệp Dịch vụ) có quyền trưng cầu cơ quan giám định độc lập tham gia giám định hàng hóa. Trong vòng 03 ngày làm việc kể từ khi kết thúc giám định, cơ quan giám định độc lập cung cấp Chứng thư giám định tình trạng và số lượng hàng hóa. Chứng thư giám định hàng hóa là căn cứ pháp lý để Bên A khiếu nại Bên B.
- 4.9 Bên B phải đảm bảo khi giao hàng hóa cho Bên A phải có kèm theo đầy đủ các chứng từ như quy định tại **Điều 3** của Hợp đồng này. Trong trường hợp Bên B giao hàng tới kho của Bên A tại Vũng Tàu nhưng chưa có đầy đủ các chứng từ theo quy định thì Bên A đồng ý cho Bên B tạm gửi hàng tại kho để chờ tập hợp đầy đủ các chứng từ cho việc giao nhận hàng hóa chính thức.  
Bên A đồng ý miễn phí lưu kho đối với lô Hàng tạm gửi này của Bên B trong 05 ngày lịch đầu tiên. Kể từ ngày thứ 6 trở đi, Bên B sẽ phải trả cho Bên A chi phí lưu kho của lô Hàng theo mức đơn giá lưu kho hiện hành của Bên A đang áp dụng cho các khách hàng của Bên A. Chi phí lưu kho này sẽ được Bên A khấu trừ thẳng vào giá trị mà Bên A thanh toán cho Bên B theo quy định của Hợp đồng này hoặc những khoản thanh toán ở những Hợp đồng khác đã ký giữa Hai Bên.
- 4.10 Bên A có quyền từ chối nhận Hàng nếu Hàng hóa khi giao không đảm bảo chất lượng, như

đã quy định ở Điều 1, Phụ lục số 01 cũng như không có đầy đủ bộ chứng từ đi kèm như quy định tại Điều 3 của Hợp đồng này.

### **Điều 5: Bao bì, Đóng gói và Ký mã hiệu**

- 5.1 Hàng hóa giao theo Hợp đồng này sẽ được đóng trong bao bì thích hợp theo tiêu chuẩn xuất khẩu, bảo đảm cho hàng hoá không bị hư hại, ăn mòn trong quá trình vận chuyển và thuận tiện cho bốc xếp, bốc dỡ.
- 5.2 Bên B hoàn toàn chịu trách nhiệm trong trường hợp hàng hoá bị mất mát, hư hỏng do thiếu sót trong việc đóng gói Hàng hoá.
- 5.3 Hàng hóa có thể được ghi rõ ràng bằng sơn không xóa được trên bề mặt hoặc in trên tấm ghi nhãn dính trên từng kiện với các thông tin sau bằng tiếng Anh hay tiếng Việt:
  - Tên nhà sản xuất.
  - Tên Hàng.
  - Khối lượng (nếu có).
  - Số Hợp đồng (nếu có).
- 5.4 Bên B chịu toàn bộ phí tổn đối với mọi mất mát/ hư hại của Hàng hoá trong quá trình bốc xếp, bốc dỡ, vận chuyển do ghi ký mã hiệu không đúng, không đầy đủ cũng như chịu mọi chi phí vận chuyển, bảo quản, mất mát phát sinh thêm do Hàng hóa bị gửi nhầm địa chỉ do ghi ký mã hiệu sai.

### **Điều 6: Trách nhiệm do vi phạm hợp đồng**

- 6.1 *Tham chiếu gói thầu của hợp đồng này, Vietsoveptro đã đánh giá và lựa chọn nhà thầu cung cấp trọn gói hoặc theo nhóm hàng, thời gian giao hàng trên áp dụng cho trọn gói hoặc theo nhóm hàng. Nếu nhà thầu không giao hoặc giao chậm bất kỳ phần hàng nào sẽ bị tính phạt giao chậm theo giá trị trọn gói hoặc theo nhóm. Nếu Bên B giao hàng bị chậm thì Bên B phải chịu phạt 0,2%/ngày cho 10 ngày lịch chậm đầu tiên; phạt 0,3%/ngày cho những ngày lịch tiếp theo tính trên tổng số giá trị hàng của hợp đồng cho đến mức tổng số tiền phạt không quá 8% giá trị trọn gói hoặc theo nhóm hàng.*

Nếu Bên B giao hàng bị chậm thì Bên B phải chịu phạt 0,2%/ngày cho 10 ngày lịch chậm đầu tiên; phạt 0,3%/ngày cho những ngày lịch tiếp theo tính trên tổng số giá trị hàng của hợp đồng cho đến mức tổng số tiền phạt không quá 08% giá trị của nhóm hàng.
- 6.2 Nếu Bên B không giao đủ số lượng, chủng loại hàng hóa (như quy định ở Phụ lục số 01 của Hợp đồng này) thì Bên B vi phạm nghĩa vụ giao hàng theo hợp đồng này và phải chịu phạt một khoản tiền bằng 08% giá trị của của nhóm hàng.
- 6.3 Nếu Bên B giao hàng không đảm bảo chất lượng như qui định tại Điều 2 của hợp đồng thì Bên A sẽ không nhận hàng và phạt Bên B theo mức phạt không giao đủ hàng như quy định tại mục 6.2 của hợp đồng này. Bên A có quyền chấp nhận / không chấp nhận việc Bên B sẽ cung cấp hàng mới thay thế cho hàng không đảm bảo chất lượng trên.
- 6.4 Nếu Bên B giao hàng chậm quá 02 tháng (60 ngày lịch) so với thời gian quy định tại mục 4.1 của hợp đồng này, ngoại trừ trường hợp bất khả kháng, thì Bên A có quyền đơn phương chấm dứt thực hiện hợp đồng và trong trường hợp này Bên B phải chịu phạt một khoản tiền bằng 08% giá trị của phần hợp đồng bị vi phạm.
- 6.5 Vi phạm do cung cấp chậm / cung cấp không đủ hàng hóa:
  - 6.5.1. Nếu Bên B giao hàng chậm quá 60 ngày lịch so với thời gian quy định tại mục 4.1 của hợp đồng này, ngoại trừ trường hợp bất khả kháng, thì Bên A có quyền:
    - a) Chỉ định bên thứ 3 có khả năng cung cấp hàng hóa. Trong trường hợp đó Bên B có trách nhiệm ký hợp đồng với bên được chỉ định để tiếp tục thực hiện công việc cung cấp cho bên A.

Hoặc:

b) Trực tiếp ký hợp đồng mua hàng/hàng hóa kèm dịch vụ của Bên thứ 3 để tiếp tục thực hiện công việc của hợp đồng. Trong trường hợp đó Bên B phải trả khoản tiền chênh lệch và các chi phí liên quan nếu có.

Hoặc:

c) Đơn phương chấm dứt thực hiện hợp đồng và trong trường hợp này Bên B phải chịu phạt một khoản tiền bằng 08% giá trị của phần hợp đồng bị vi phạm.

6.5.2. Nếu Bên B giao hàng chậm (một phần hàng hoá) quá 60 ngày lịch so với thời gian quy định tại mục 4.1 của hợp đồng này, ngoại trừ trường hợp bất khả kháng, thì Bên A có quyền:

a) Chỉ định Bên thứ 3 có khả năng cung cấp hàng hóa. Trong trường hợp đó Bên B có trách nhiệm ký hợp đồng với Bên được chỉ định để tiếp tục thực hiện công việc cung cấp cho Bên A.

Hoặc:

b) Trực tiếp ký hợp đồng mua hàng/hàng hoá kèm dịch vụ của Bên thứ 3 để tiếp tục thực hiện công việc của hợp đồng. Trong trường hợp đó Bên B phải trả khoản tiền chênh lệch và các chi phí liên quan nếu có.

Hoặc:

c) Đơn phương chấm dứt thực hiện tiếp hợp đồng và trong trường hợp này Bên B phải chịu phạt một khoản tiền bằng 08% giá trị của phần hợp đồng bị vi phạm.

6.6 Tổng các loại phạt không vượt quá 08% giá trị hợp đồng.

6.7 Giá trị hợp đồng bị vi phạm ghi ở Điều 5 của hợp đồng này là giá trị không có thuế GTGT và không bao gồm thuế nhập khẩu.

6.8 Để thu hồi khoản tiền phạt vi phạm, Bên A sẽ toàn quyền: 1) khấu trừ khoản tiền phạt vi phạm từ các khoản tiền mà Bên A sẽ thanh toán cho Bên B tại Hợp đồng này hoặc theo các hợp đồng khác được ký kết giữa hai Bên; 2) Yêu cầu Ngân hàng cấp Bảo đảm thực hiện hợp đồng thanh toán ngay khoản tiền Bên B mở bảo lãnh cho Bên A; 3) Bằng văn bản, yêu cầu Bên B thanh toán. Trong mọi trường hợp, Bên B cam kết nghiêm túc thực hiện nghĩa vụ thanh toán của mình cho Bên A.

6.9 Việc bồi thường thiệt hại (nếu có) được thực hiện theo quy định của pháp luật Việt Nam.

## **Điều 7: Bảo hành**

7.1 Bên B chịu trách nhiệm bảo hành chất lượng của hàng hóa trong thời hạn ..... kể từ ngày giao hàng. Điều kiện bảo hành theo đúng tiêu chuẩn bảo hành của nhà sản xuất.

7.2 Trong thời gian bảo hành nếu Bên A phát hiện có hư hỏng, sai sót về chất lượng hàng hoá thì Bên A sẽ thông báo kịp thời bằng fax/email cho Bên B biết để cùng nhau xác minh. Việc xác minh sai sót về chất lượng phải được Bên B tiến hành không chậm quá 15 ngày lịch kể từ ngày Bên B nhận được thông báo. Việc xác minh phải được lập thành biên bản, trong đó ghi rõ kết luận về nguyên nhân gây ra hư hỏng, xác định trách nhiệm thay thế cái mới/sửa chữa các hư hỏng đó thuộc về bên nào và thời hạn thay thế/sửa chữa làm căn cứ pháp lý trong thực hiện hợp đồng này.

7.3 Tùy mức độ hư hỏng, nhưng không quá 15 ngày lịch kể từ ngày có kết luận về nguyên nhân hư hỏng, sai sót về chất lượng hàng hoá do lỗi của Bên B thì Bên B phải tiến hành sửa chữa các sai sót về chất lượng hoặc đổi lại hàng mới cho Bên A.

7.4 Trong thời hạn 07 ngày lịch kể từ ngày nhận được thông báo của Bên A, nếu Bên B không trả lời thì coi như đã chấp nhận có sai sót về chất lượng hàng do lỗi của mình và có trách nhiệm phải sửa chữa các sai sót đó hoặc đổi lại hàng mới ngay trong vòng 15 ngày kể từ ngày nhận được thông báo của Bên A.

7.5 Nếu Bên B tiến hành sửa chữa hoặc đổi lại hàng mới bị chậm so với thời hạn qui định ở mục 7.3 và 7.4 của hợp đồng này thì Bên B phải chịu phạt theo mức phạt giao hàng chậm như qui định ở mục 6.1 của hợp đồng này.

- 7.6 Trong thời hạn quy định trên tại điều 7 của hợp đồng này, nếu Bên B không tiến hành khắc phục (sửa chữa các sai sót về chất lượng do lỗi của mình hoặc đổi lại hàng mới) thì Bên A có quyền tiến hành khắc phục (sửa chữa và/hoặc thay mới) và Bên B phải hoàn trả lại cho Bên A toàn bộ chi phí khắc phục, đồng thời phải chịu phạt 08% giá trị của mặt hàng này. Cách thức Bên A thu hồi tiền phạt từ Bên B quy định tại điều 6.7 của hợp đồng này.
- 7.7 Hàng hóa sau khi được Bên B sửa chữa và thay thế trong thời kỳ bảo hành sẽ được Bên B bảo hành lại 12 tháng kể từ ngày bàn giao (có Biên bản giao nhận hàng như quy định tại Phụ lục số 02 của hợp đồng này).

## **Điều 8: Thanh toán**

- 8.1 Bên A thanh toán cho Bên B 100% giá trị hóa đơn hàng đã giao bằng phương thức chuyển khoản qua ngân hàng trong vòng 30 ngày làm việc kể từ ngày nhận được bộ chứng từ thanh toán gồm:
- 02 Hóa đơn thuế GTGT (02 bản gốc), trong đó:
    - + Hóa đơn số 01: Cho giá trị hàng hóa được miễn thuế GTGT và thuế nhập khẩu ở khâu nhập khẩu: tỷ giá quy đổi sang VNĐ lấy theo tỷ giá ghi trên tờ khai Hải quan; trên hóa đơn chỉ ghi dòng giá bán là giá không có thuế GTGT, dòng thuế suất và giá trị thuế GTGT không ghi và được gạch bỏ hoặc theo các quy định hiện hành của pháp luật tại ngày xuất hóa đơn.
    - + Hóa đơn số 02: Cho phần phát sinh chênh lệch giữa giá trị hàng hóa đã khai báo tại khâu nhập khẩu và giá trị hàng hóa ghi trong hợp đồng này; trên hóa đơn, dòng thuế suất và giá trị thuế GTGT ghi giá trị phù hợp với quy định hiện hành.
  - 01 bản gốc Biên bản giao nhận hàng (Điều 4.8 của Hợp đồng này).
  - Chứng thư giám định (nếu có trung cầu quy định tại Điều 4.9 của Hợp đồng này).
  - Các chứng từ (theo quy định tại Điều 3.2 của Hợp đồng này).
  - Bảo đảm thực hiện Hợp đồng (01 bản copy).
  - Tờ khai Hải quan hàng nhập khẩu (01 bản copy).
- 8.2 Bên A chỉ thanh toán cho Bên B đối với hàng hóa hoàn toàn phù hợp với yêu cầu nêu trong hợp đồng.
- 8.3 Số tài khoản giao dịch theo hợp đồng này của Bên B:
- Số tài khoản: .....
  - Tên Ngân hàng .....
  - Người thụ hưởng: .....
- 8.4 Phí chuyển tiền do Bên A chịu.

## **Điều 9: Bảo đảm thực hiện Hợp đồng**

- 9.1 Trong vòng 07 ngày làm việc sau ngày ký hợp đồng (ghi tại trang 01 của hợp đồng), Bên B phải nộp giấy bảo lãnh thực hiện hợp đồng (Phụ lục số 03 của hợp đồng này) được cấp bởi Ngân hàng có uy tín. Giá trị Bảo đảm thực hiện hợp đồng bằng 03% tổng giá trị hợp đồng. Giấy bảo lãnh này có hiệu lực bằng thời hạn giao hàng quy định tại mục 4.1 hợp đồng này cộng thêm 60 ngày lịch.
- 9.2 Mọi chi phí liên quan đến việc phát hành giấy bảo lãnh thực hiện hợp đồng do Bên B chịu.
- 9.3 Trong thời gian quy định tại mục 9.1 nêu trên, Bên B phải nộp bản gốc bảo lãnh thực hiện hợp đồng cho Bên A. Nếu sau thời gian quy định nói trên, Bên A không nhận được bảo lãnh thực hiện Hợp đồng thì Bên A có quyền đơn phương chấm dứt Hợp đồng và không hoàn trả Bảo đảm dự thầu của Bên B hoặc áp dụng quy định tại mục 6.8 của Hợp đồng này.
- 9.4 Bên B không được nhận lại Bảo đảm thực hiện hợp đồng trong trường hợp Bên B từ chối/không thực hiện hợp đồng sau khi ký hợp đồng.
- 9.5 Trong trường hợp Bên B vi phạm trách nhiệm thực hiện hợp đồng theo quy định tại hợp đồng này thì khoản tiền bảo đảm được Bên A dùng để khấu trừ tiền phạt.

- 9.6 Bên B phải ngay lập tức yêu cầu Ngân hàng phát hành Bảo đảm thực hiện Hợp đồng thực hiện việc sửa đổi Bảo đảm thực hiện Hợp đồng trong trường hợp cần gia hạn thời gian hiệu lực của Bảo đảm này vì lý do chậm thực hiện hoặc gia hạn thời gian thực hiện, đồng thời gửi cho Bên A bản gốc Bảo đảm thực hiện Hợp đồng đã được gia hạn hiệu lực chậm nhất là 07 ngày làm việc trước khi Bảo đảm thực hiện Hợp đồng cũ hết hiệu lực.

Trường hợp Bên B chậm gia hạn hiệu lực bảo lãnh khi có yêu cầu của Bên A bằng văn bản thì Bên B sẽ chịu phạt 0,2% giá trị bảo lãnh tương ứng/mỗi ngày chậm. Tổng giá trị phạt này không vượt quá 08% giá trị bảo lãnh tương ứng.

### **Điều 10: Bất khả kháng**

- 10.1 Sự kiện bất khả kháng là sự kiện xảy ra một cách khách quan không thể lường trước được và không thể khắc phục được mặc dù đã áp dụng mọi biện pháp cần thiết và khả năng cho phép như: chiến tranh, bạo loạn, xung đột vũ trang, cấm vận, thiên tai (lũ lụt, bão, lốc xoáy, động đất, sóng thần), hỏa hoạn, dịch bệnh (Epidemic, Pandemic) được WHO/Quốc gia công bố, lệnh phong tỏa Vùng/Quốc gia do Chính quyền sở tại áp đặt, ...
- 10.2 Bên gặp sự kiện bất khả kháng dẫn đến việc không thực hiện được nghĩa vụ theo hợp đồng do ảnh hưởng trực tiếp bởi các sự kiện bất khả kháng có nghĩa vụ phải ngay lập tức thông báo cho bên kia biết, bao gồm cung cấp thông tin, giải trình về sự ảnh hưởng trực tiếp của sự kiện bất khả kháng đến việc vi phạm thực hiện hợp đồng kèm chứng cứ chứng minh, các biện pháp đã được thực hiện để khắc phục vấn đề và giảm thiểu tổn thất. Việc chậm thông báo, cung cấp thông tin và giải trình nếu trễ hơn 14 ngày lịch sau khi sự kiện bất khả kháng xảy ra sẽ làm cho bên gặp bất khả kháng mất quyền miễn trách sau này vì lý do bất khả kháng.
- 10.3 Văn bản xác nhận của Phòng Thương mại và Công nghiệp Việt Nam hoặc cơ quan có thẩm quyền ở nơi xảy ra sự kiện bất khả kháng là bằng chứng đủ để chứng minh sự kiện và thời gian xảy ra bất khả kháng.
- 10.4 Trường hợp do hậu quả trực tiếp của sự kiện bất khả kháng mà một Bên trong Hợp đồng không thể thực hiện toàn bộ hoặc một phần nghĩa vụ theo Hợp đồng này thì thời gian thực hiện Hợp đồng sẽ được kéo dài thêm bằng thời gian mà sự kiện bất khả kháng diễn ra.
- 10.5 Nếu sự kiện bất khả kháng kéo dài hơn 02 tháng, mỗi bên đều có quyền chấm dứt hợp đồng này mà không phải bồi thường bất cứ một khoản tiền nào cho bên kia.
- 10.6 Các khó khăn trong sản xuất như thiếu vật tư, điện, nhân công, đình công... không được coi là bất khả kháng và không miễn cho Bên B nghĩa vụ giao hàng hoặc giao hàng muộn; Các thông tin từ trang báo, mạng và các phương tiện truyền thông khác chỉ mang tính chất tham khảo.

### **Điều 11: Giải quyết tranh chấp**

- 11.1 Bất kỳ tranh chấp nào phát sinh từ hợp đồng này sẽ được giải quyết bằng thương lượng giữa hai bên trên tinh thần hợp tác, hai bên cùng có lợi và tôn trọng lẫn nhau.
- 11.2 Trường hợp tranh chấp không thể giải quyết bằng thương lượng thì sẽ được giải quyết bằng trọng tài tại Trung tâm Trọng tài Quốc tế Việt Nam (VIAC) tại Hà Nội theo Quy tắc tổ tụng trọng tài của Trung tâm này.
- Số lượng trọng tài viên là 03 người.
- Luật áp dụng là Luật Việt Nam.
- Phán quyết của Trung tâm trọng tài là cuối cùng và buộc hai Bên phải tuân thủ.
- Trọng tài phí do Bên thua kiện chịu.

### **Điều 12: Các điều khoản khác**

- 12.1 Bất kỳ sự sửa đổi, bổ sung nào đối với Hợp đồng này đều phải được lập thành văn bản và có

chữ ký của cả hai bên. Mọi giao dịch trong quá trình thực hiện Hợp đồng được các Bên thực hiện bằng văn bản và gửi theo đường bưu chính hoặc theo số Fax tới địa chỉ đăng ký hoặc số Fax của mỗi Bên ghi trong hợp đồng và email đến địa chỉ email ... theo mẫu thể hiện tại Phụ lục số 04 (A, B) kèm theo.

- 12.2 Những điều không quy định hoặc quy định không đầy đủ trong Hợp đồng này sẽ căn cứ vào luật pháp Việt Nam hiện hành.
- 12.3 Không Bên nào được chuyển quyền và nghĩa vụ của mình theo hợp đồng này cho Bên thứ ba mà không được sự đồng ý trước bằng văn bản của Bên kia.
- 12.4 Trong quá trình thực hiện hợp đồng trường hợp xảy ra tranh chấp thì các văn bản dẫn chiếu được xem xét theo thứ tự ưu tiên xử lý theo mục Mục 2.2 ĐKC.
- 12.5 Hợp đồng này có hiệu lực kể từ ngày Ngân hàng Bên B mở bảo lãnh thực hiện Hợp đồng (ngày hiệu lực của bảo lãnh) và hoàn thành việc ký Hợp đồng nhưng không muộn hơn 7 ngày làm việc so với ngày được ghi trên Hợp đồng và tiếp tục cho đến khi hai Bên thực hiện hết trách nhiệm của mình như quy định trong hợp đồng.
- 12.6 Hết thời hạn hiệu lực của hợp đồng, nếu hai bên không có khiếu nại gì coi như hợp đồng đã được thanh lý.
- 12.7 Hợp đồng gồm ..... trang và 04 Phụ lục (Phụ lục số 01: Phạm vi cung cấp và bảng giá trị, Phụ lục số 02: Biên bản giao nhận hàng, Phụ lục số 03: Bảo lãnh thực hiện Hợp đồng và Phụ lục số 04 (A, B): Mẫu Phương thức giao dịch) được lập thành 05 bản bằng tiếng Việt (có sử dụng tiếng Anh mô tả hàng hóa tại Phụ lục số 01), các bản có giá trị pháp lý như nhau, Bên A giữ 04 bản, Bên B giữ 01 bản.

**ĐẠI DIỆN BÊN A**

**ĐẠI DIỆN BÊN B**

**PHỤ LỤC SỐ 01**  
**HỢP ĐỒNG SỐ .....**

**PHẠM VI CUNG CẤP VÀ GIÁ TRỊ HÀNG HÓA**  
Mua ..... (Lô 09-1)

Số TT	Tên hàng, Ký hiệu, Quy cách	Mô tả	Model, P/N	Nhà sản xuất	Xuất xứ (CO)	ĐVT	Số lượng cung cấp	Đơn giá (VND)	Thành tiền (VND)	
<b>I.</b>	.....	<b>Hàng hóa sử dụng hạn ngạch để nhập khẩu, hàng hóa sử dụng Quota Lô 09-1</b>								
1.	.....					Set/pc		.....	.....	
2.	.....							.....	.....	
	.....							.....	.....	
n	.....							.....	.....	
	<b>Thành tiền I</b>	<i>Giá trị Hàng hóa không bao gồm thuế GTGT và thuế nhập khẩu của giá trị hàng hóa nhập khẩu ghi trên Tờ khai Hải quan nhưng đã bao gồm toàn bộ các thuế, phí và chi phí phát sinh trong lãnh thổ Việt Nam</i>							.....	.....
<b>II.</b>	.....	<b>Hàng hóa không sử dụng hạn ngạch để nhập khẩu (Hàng hóa mua trong nước hoặc hàng hóa được sản xuất tại Việt Nam)</b>								
1.	.....					Set/pc		.....	.....	
2.	.....							.....	.....	
	.....							.....	.....	
n	.....							.....	.....	
		<i>* Giá trị Hàng hóa chưa bao gồm GTGT</i>							.....	.....
		<i>* Thuế GTGT (áp dụng theo Quy định hiện hành của Việt Nam)</i>							.....	.....
	<b>Thành tiền II</b>	<i>Giá trị Hàng hóa đã bao gồm thuế GTGT và bao gồm toàn bộ các thuế, phí và chi phí phát sinh trong lãnh thổ Việt Nam</i>							.....	.....
		<b>Tổng giá trị hợp đồng (mục I+II)</b> <i>* (áp dụng cho mục I) Giá trị Hàng hóa không bao gồm thuế GTGT và thuế nhập khẩu của giá trị hàng hóa nhập khẩu ghi trên Tờ khai Hải quan nhưng đã bao gồm toàn bộ các thuế, phí và chi phí phát sinh trong lãnh thổ Việt Nam</i> <i>* (áp dụng cho mục II) Giá trị hợp đồng trên đã bao gồm thuế GTGT và bao gồm toàn bộ các thuế, phí và chi phí</i>							.....	.....

		<b>phát sinh trong lãnh thổ Việt Nam cho Hàng hóa mua trong nước</b>		
--	--	----------------------------------------------------------------------	--	--

**ĐẠI DIỆN BÊN A**

**ĐẠI DIỆN BÊN B**

**PHỤ LỤC SỐ 02**  
**HỢP ĐỒNG SỐ .....**

Phê duyệt - Утверждаю  
Thủ trưởng đơn vị đặt hàng  
Директор пред-я заказчика

Phê duyệt - Утверждаю  
Giám đốc XNDV Cảng & Cung ứng vật tư TB  
Директор ПОСОМ

Ngày.....tháng.....năm 20....

Ngày.....tháng.....năm 20....

**BIÊN BẢN GIAO NHẬN HÀNG**  
**АКТ О ПРИЁМЕ - ПЕРЕДАЧЕ ТОВАРОВ**

Ngày.... tháng.... năm 20....

Căn cứ HĐ (biên bản) số:

ký ngày.... tháng....năm 20...

На основании Договора номер:

Chúng tôi, những người ký tên dưới đây - Мы. Нижеподписавшиеся:

**1- Đại diện bên giao - Представители поставщика:**

- Ông (Bà) Chức vụ:

- Ông (Bà): Chức vụ:

**2- Đại diện bên nhận - Представители получателя:**

**2.1 XN dịch vụ cảng & cung ứng vật tư TB - ПОСОМ**

- Ông (Bà): Chức vụ:

- Ông (Bà): Chức vụ:

**2.2 Đơn vị đặt hàng - Представители предприятия - заказчика:**

- Ông (Bà): Chức vụ:

- Ông (Bà): Chức vụ:

- Ông (Bà): Chức vụ:

- Ông (Bà): Chức vụ:

Cùng nhau tiến hành giao nhận hàng hóa, cụ thể như sau: - Произвели приёмо - передачу следующих товаров на складе:...

STT П/П	Tên hàng, Ký hiệu, Quy cách Наименование, марка товаров	ĐVT ЕД	Thực nhập Фак. Получение		Bao bì Тара	Chất lượng hàng Качество
			Số lượng Кол.	Trọng lượng Вес.		

- Mẫu phân tích các mặt hàng No. .... được lấy tại ..... - Образец товара получен на складе:  
..... ngày ..... tháng ..... năm 20...

- Người lấy mẫu - **Приемщик:** ..... Chức vụ - Должность:

- Người lấy mẫu - **Приемщик:** ..... Chức vụ - Должность:

Đối với những mặt hàng lấy mẫu phân tích nêu trên thì hàng chỉ chuyên chủ từ Bên giao sang Bên nhận. Sau khi có kết quả phân tích mẫu đạt yêu cầu như mẫu chào hàng. Trong thời gian chờ kết quả phân tích mẫu, Bên nhận (XNDV hoặc đơn vị đặt hàng) nhận giữ hộ.

#### CHỨNG TỪ KÈM THEO - Прилагаемые документы:

- Chứng chỉ phẩm chất - Сертификат:.....

- Hóa đơn ( phiếu xuất kho ) - Счёт: .....

- Bản kê chi tiết danh điểm mặt hàng ( Перечень товаров) gồm \_\_ bản \_\_ tờ

- Các chứng từ khác - Другие документы : .....

Biên bản này chỉ lập một bản và chỉ có giá trị để làm thủ tục thanh toán sau khi được Giám đốc XNDVCảng & Cung ứng vật tư TB và lãnh đạo đơn vị đặt hàng phê duyệt (trường hợp giao nhận thẳng cho đơn vị đặt hàng thì biên bản này phải được thủ trưởng đơn vị đặt hàng phê duyệt trước). Ngày giao hàng của lô hàng này là ...

#### ĐẠI DIỆN BÊN GIAO

#### KÝ TÊN - Подписи

#### ĐẠI DIỆN BÊN NHẬN

Представители поставщика:

Представители получателя:

(Họ tên và chữ ký)

(Họ tên và chữ ký)

Xác nhận chất lượng của phòng thí nghiệm hoặc đơn vị đặt hàng (nếu có) - Справка лаборатории (заказчика) по качеству

Đại diện phòng thí nghiệm (Hoặc đơn vị đặt hàng) - Представитель лаборатории (заказчика)

Họ và tên - Фамилия .....

Ký tên: Подпись

Ngày.....tháng.....năm 20....

Kiểm tra và xác nhận: Các mặt hàng nêu trên có số lượng, ký mã hiệu, xuất xứ hàng hóa, chứng chỉ chất lượng & được kiểm tra chất lượng v.v. phù hợp với các quy định của hợp đồng (Biên bản) Kết luận:

Sостояние товаров. Количество марки. Место происхождения. Сертификат по качеству и проверка качества....вышеуказанных товаров соответствуют условиям Договора:

**T.P vật tư thiết bị** - Начальник курирующего отделаю

Ký tên: Подпись

Ngày.....tháng.....năm 20....

**Trưởng phòng TННĐ** - Начальник ОКД

Ký tên: Подпись

Ngày.....tháng.....năm 20....

**PHỤ LỤC SỐ 03**  
**HỢP ĐỒNG SỐ .....**  
**MẪU BẢO LÃNH THỰC HIỆN HỢP ĐỒNG**

Ngày      tháng      năm

TO: \_\_\_\_\_ [name of the Employer]  
(Hereinafter referred to as the "Employer")

Liên quan tới Hợp đồng \_\_\_\_\_ về việc \_\_\_\_\_ (sau đây được gọi là "Hợp đồng") được ký giữa \_\_\_\_\_ (sau đây gọi là "BÊN ĐƯỢC BẢO LÃNH") và \_\_\_\_\_ (sau đây gọi là "BÊN THỤ HƯỞNG"), chúng tôi, \_\_\_\_\_ có trụ sở chính tại \_\_\_\_\_ (sau đây gọi là "BÊN BẢO LÃNH") phát hành Thư bảo lãnh không hủy ngang và vô điều kiện cho bên thụ hưởng với số tiền là \_\_\_\_\_ (Bằng chữ: \_\_\_\_\_) (sau đây gọi là "THƯ BẢO LÃNH").

THƯ BẢO LÃNH này có hiệu lực kể từ ngày phát hành và sẽ duy trì hiệu lực cho đến \_\_\_\_\_ sau đây gọi là "Ngày hết hiệu lực". Đối với bất cứ sự gia hạn, đổi mới hoặc chuyển nhượng Hợp đồng vượt quá thời gian được quy định trong THƯ BẢO LÃNH này, BÊN THỤ HƯỞNG sẽ không cần phải thông báo hoặc được sự đồng thuận của BÊN BẢO LÃNH. THƯ BẢO LÃNH này sẽ được gia hạn dựa trên yêu cầu bằng văn bản từ BÊN ĐƯỢC BẢO LÃNH để đảm bảo cho thời gian gia hạn, đổi mới hoặc chuyển nhượng của Hợp đồng.

BÊN BẢO LÃNH cam kết **không hủy ngang và vô điều kiện** thanh toán ngay cho BÊN THỤ HƯỞNG một khoản tiền hay những khoản tiền, theo chỉ thị của BÊN THỤ HƯỞNG, tổng không vượt quá số tiền bảo lãnh nêu trên trong vòng 05 ngày làm việc kể từ ngày nhận được văn bản yêu cầu của BÊN THỤ HƯỞNG ghi rõ BÊN ĐƯỢC BẢO LÃNH đã vi phạm nghĩa vụ theo Hợp đồng. Sau Ngày hết hiệu lực, THƯ BẢO LÃNH này sẽ tự động không còn giá trị cho dù bản gốc THƯ BẢO LÃNH và các Thư sửa đổi liên quan (nếu có) có được gửi trả lại BÊN BẢO LÃNH hay không.

Số tiền bảo lãnh nêu trên sẽ được thanh toán ngay bởi BÊN BẢO LÃNH cho BÊN THỤ HƯỞNG cho dù có sự tranh cãi hoặc phản đối nào của BÊN ĐƯỢC BẢO LÃNH hoặc của BÊN BẢO LÃNH hoặc của bất kỳ bên thứ ba nào khác, và bất kể có hay không sự tranh chấp giữa BÊN ĐƯỢC BẢO LÃNH và BÊN THỤ HƯỞNG về hoặc liên quan tới Hợp đồng hoặc về bất cứ vấn đề khác và cho dù những tranh chấp này, nếu có, đã được giải quyết, dàn xếp, kiện tụng hoặc phân xử bằng bất kỳ hình thức nào.

BÊN BẢO LÃNH hoặc BÊN ĐƯỢC BẢO LÃNH sẽ không được giải trừ bất cứ nghĩa vụ nào theo THƯ BẢO LÃNH này cho dù có bất cứ sự sửa đổi, thay đổi, thanh toán sai lệch, gia hạn nào liên quan tới Hợp đồng hay bất kỳ sự trì hoãn ân hạn nào của BÊN THỤ HƯỞNG trong hoặc liên quan đến bất cứ vấn đề gì của Hợp đồng.

Việc đòi tiền nhiều lần theo bảo lãnh này là được phép và theo đó, Số tiền bảo lãnh nêu trên sẽ tự động giảm tương ứng với số tiền mà Ngân hàng đã thực hiện thanh toán cho Bên thụ hưởng theo Thư bảo lãnh.

Thư bảo lãnh được điều chỉnh và giải thích theo pháp luật Việt Nam. Bất kỳ tranh chấp nào phát sinh từ hoặc liên quan đến Thư bảo lãnh sẽ [do Tòa án nhân dân có thẩm quyền của Việt Nam giải quyết theo quy định của pháp luật] / [sẽ được giải quyết tại Trung tâm Trọng tài quốc tế Việt Nam (VIAC) bên cạnh Phòng Thương mại và Công nghiệp Việt Nam theo quy tắc tố tụng trọng tài của VIAC].

THƯ BẢO LÃNH này được phát hành duy nhất 01 (một) bản bằng tiếng Việt và không được phép chuyển nhượng.

**NGÂN HÀNG BẢO LÃNH**  
[Ký tên và đóng dấu]

**PHỤ LỤC SỐ 04 (A)**  
**HỢP ĐỒNG SỐ .....**  
**MẪU THƯ TÍN GIAO DỊCH THỰC HIỆN HỢP ĐỒNG**

Ngày      tháng      năm 20..

**Kính gửi:**      **Liên doanh Việt – Nga Vietsovet / Nhà thầu**  
*(ghi địa chỉ số Fax của Bên giao dịch)*

Người nhận: *Họ và tên + Chức danh của Lãnh đạo VSP ký hợp đồng*

Sao gửi:      Lãnh đạo phòng Thương mại VSP

Email:      [vspadmin@vietsov.com.vn](mailto:vspadmin@vietsov.com.vn)

*(Đồng thời gửi e-mail đến địa chỉ của Người thực hiện / Người phụ trách – sẽ ghi chi tiết khi ký kết hợp đồng)*

**(Ghi nội dung giao dịch về:** Thay đổi về Hàng hóa / Dịch vụ, tiến độ, sử dụng Quota, các nội dung liên quan tới giá trị Hợp đồng, thanh toán, .....).

**ĐẠI DIỆN BÊN ...**  
*(Ký tên và đóng dấu)*

**PHỤ LỤC SỐ 04 (B)**  
**HỢP ĐỒNG SỐ .....**  
**MẪU THƯ TÍN GIAO DỊCH THỰC HIỆN HỢP ĐỒNG**

*Ngày      tháng      năm 20..*

**Kính gửi:**      **Liên doanh Việt – Nga Vietsovetro / Nhà thầu**  
*(ghi địa chỉ số Fax của Bên giao dịch)*

Người nhận: *Phòng Thương mại VSP / XN Dịch vụ Cảng và CUVTTB / Đơn vị đặt hàng*

Email:      [vspadmin@vietsov.com.vn](mailto:vspadmin@vietsov.com.vn)  
*(Đồng thời gửi e-mail đến địa chỉ của Người thực hiện / Người phụ trách – sẽ ghi chi tiết khi ký kết hợp đồng)*

**(Ghi nội dung giao dịch về:** Thông báo giao hàng, gửi chứng từ hàng hóa, thông báo bắt đầu thực hiện Dịch vụ, thông tin về nhân sự / thiết bị thực hiện Dịch vụ, .....).

**ĐẠI DIỆN BÊN ...**  
*(Ký tên và đóng dấu)*

## **Part 4. APPENDICES**

**This Chapter includes:**

**1 - Attachment 01: SCOPE OF SUPPLY (01 PAGE)**

**2 - Attachment 02: TECHNICAL REQUIREMENT (02 PAGES)**

**3 - Attachment 03: TECHNICAL EVALUATION CRITERIA (03 PAGES)**

**And other Technical documents, ... with link for reference (if any).**



## DANH MỤC- СПЕЦИФИКАЦИЯ

Tên hàng hóa/Dịch vụ - На приобретение товаров/услуг: Tời hơi cho giàn Tam Đảo 02/ Пневматическая лебедка для СПБУ Там Дао 02

Số ĐHXN - № заявки: 90.XNKВ-0551/25-VT

STT П/п	Mã Vật Tư Код МТР	Tên VTTB/dịch vụ (Việt/Nga hoặc Anh) Наименование МТР/услуг (вьетнам./русс. или англ.)	Đặc Tính Kỹ Thuật Технические характеристики	ĐVT Ед. Изм.	Số Lượng Кол-во	Ghi Chú Примечание
(1)	(2)	(3)	(4)	(5)	(6)	(7)
<b>I. VẬT TƯ THIẾT BỊ</b>						
1	032.006.00246	Air winch manual control infinity with 11.000 lbs (5000kg), drum length 24" - Tời hơi/Пневматическая Лебедка	Air winch, capacity 11,000 lb (5 metric ton), Drum length 24"± 3%, with an all steel frame and powerful piston air motor, air inlet 1-1/4" NPT. Motor exhaust 2-1/2" NPT. Lifting speed 10m/min ± 5% for first layer, motor 18.8 Kw ± 5%, air consumption 20m <sup>3</sup> /min ± 5%, wire rope 3/4". Automatic Disc Brake, Std throttle lever., 150m steel wire rope 3/4" included.	Set	1,00	





**TECHNICAL EVALUATION CRITERIA  
BIDDING PACKAGE: AIR WINCH 5 TON FOR TAM DAO 02**

№	Criteria	Proposal content	Evaluation “Pass/ Fail”	Reason for failed	Note
1	2	3	4	5	6
<b>1</b>	<b>General Requirements</b>				
1.1	Goods condition				
		New and unused	Passed		
		Used/ refurbished goods	Failed	Not suitable for VSP needs	
1.2	Year of manufacture				
		Goods are not manufactured before 2025.	Passed		
		Goods are manufactured before 2025.	Failed	Not suitable for VSP needs	
1.3	Bid proposal content				
		Offer for each item of goods includes product name, part number (if any), manufacturer and country of origin.	Passed		
		The information required above is not clear.	Failed	Lack of information to evaluate.	
1.4	Guarantee				
		Not less than 12 months from the date of signing the goods delivery report(s).	Passed		
		Not mentioned or warranty period is less than 12 months.	Failed	Quality/longevity of Goods do not assure.	
<b>2</b>	<b>Technical Requirements</b>				
		The technical specifications of goods must meet the requirements described in section <b>3-Technical requirements</b> or <b>Equivalent</b>	Passed		
		Does not meet the above requirement.	Failed	There is no guarantee for the suitability of goods.	
<b>3</b>	<b>Time and Location Of Delivery:</b>				
3.1	Delivery time				
		5 months from the day of signing the contract.	Passed		

		Later than the above delivery time by 1-15 days.	Accepted		
		Does not meet the above requirements.	Failed	Risk of not meeting the schedule of production.	
<b>4</b>	<b>Quantity and Packing</b>				
4.1	Quantity				
		Meet the quantity of goods in the Requisition.	Passed		
		Does not meet the above requirement.	Failed	Goods are not enough for operation equipment.	
4.2	Packing				
		Goods shall be packed in accordance with international standards for export packing to ensure safety of Goods from damages and corrosion during transportation and suitable for crane operations and handling.	Passed		
		No commitment to packing goods as above required.	Failed	Risk of damage to goods during transportation and storage.	
<b>5</b>	<b>Technical Documentation</b>				
5.1	During bidding:				
		Technical documents, catalogs required for bidding stage: including but not limited to datasheets/ catalogs/ technical specifications of manufacture/ technical proposal...which must contain sufficient technical information in sections 2, 3 of The Technical requirements for evaluation.	Passed		
		Does not meet the above requirement.	Failed	Lack of information to evaluate.	
5.2	Upon delivery:				
		Bidder must commit that required document listed in Section 6.2- Technical requirements will be supplied upon delivery.	Passed		
		There are changes in the form of the technical document but it still shows full required information.	Accepted		
		Does not meet the above requirement.	Failed		
<b>6</b>	<b>Certificates</b>				
		Bidder must commit that required certificates listed in Section 7- Technical requirements will be supplied upon delivery.	Passed		
		There are changes in the form of the certificate but it still shows full required information.	Accepted		
		Not mentioned or does not meet above requirements.	Failed		





Văn bản này được xác thực tại <https://eoffice.vietsov.com.vn> với số định danh: 1109/26-CV-KHOAN

## TECHNICAL REQUIREMENTS AIR WINCH 5 TON FOR TAM DAO 02

*"Air winch 5 ton for tam dao 02" hereinafter referred to as "Goods"*

### 1. PURPOSE AND SCOPE OF USE:

- 1.1. Purpose of use: The goods are intended to replace broken ones of jackup rigs Tam Dao 02 for uninterrupted operation.
- 1.2. Area of operation of the Goods is offshore in Oil and Gas drilling activities.
- 1.3. Normal operation: in tropical area condition regarding environment temperature from 10 to 45 Deg.C, humidity from 30 to 90%

### 2. GENERAL REQUIREMENTS:

- 2.1. Goods condition: Goods must be 100% brand new, are not manufactured before 2025.
- 2.2. Bid Proposal must include the product name, part number (if any), manufacturer's name and origin of each item.
- 2.3. Bidder guarantees normal operation of all Goods to be supplied over 12 months from the date of delivery.

### 3. TECHNICAL REQUIREMENTS AND TECHNOLOGY FOR COMPONENTS:

3.1. Goods should meet all requirements of technical specifications in the Requisition *or equivalent. The required technical specifications* are as follows:

- + Capacity: 11,000 lbs (5 metric ton), all steel frame and powerful piston air motor, , Lifting speed  $\geq 9$  m/min, can be operated with air pressure  $\leq 150$ psi.
- + Drum Length (Distance between drum flanges)  $\geq 16$ in, maximum rope storage capacity  $\geq 150$ m.
- + Maximum Net Weight: 1000kg.
- + Total dimensions C x B  $\leq 36,3 \times 35 \pm 10\%$ ; A  $\leq 36,5 \pm 15\%$

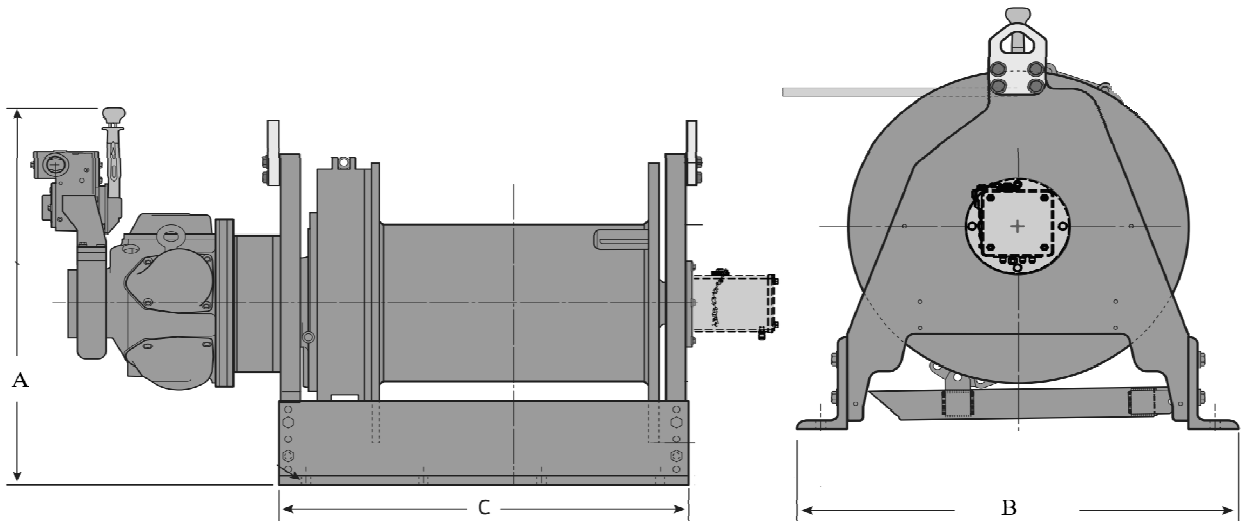

- + Include: Automatic Disc Brake, Drum Guard.
- + Control: Winch mounted lever throttle.
- + Paint coat: Marine Corrosion Protection Coating
- + Wire rope included: minimum 120m x 3/4inch Diameter 6x36 IWRC RHOL galvanized steel wire rope, one end talurit splice with thimble.

#### **4. TIME AND LOCATION OF DELIVERY:**

- 4.1. Delivery time: 5 months from the day of signing the contract.
- 4.2. Delivery location: VSP 's warehouse (No. 67, 30/4 street, Thang Nhat ward, Vung Tau city, BRVT province, Viet Nam.
- 4.3. Number of shipments: 1 shipment.

#### **5. QUANTITY AND PACKAGING:**

- 5.1. Quantity of goods must match the requirements in the Requisition.
- 5.2. Goods shall be packed in accordance with international standards for export packing to ensure safety of Goods from damages and corrosion during transportation and suitable for crane operations and handling.

#### **6. TECHNICAL DOCUMENTATION REQUIREMENTS:**

- 6.1. Upon bidding:  
Technical document, catalogs required at bidding stage: including but not limited to datasheets/ catalogs/ technical specifications of manufacture/ technical proposal...which must have enough technical information in section 2, 3 of *Technical requirements* for evaluation.
- 6.2. Upon delivery: technical datasheet (including information about sizes, working load, weight, manufacturing material).

#### **7. REQUIREMENTS FOR GOODS CERTIFICATES**

- 7.1. The Certificate of Origin (CO) issued by the competent authority (CO must present the country of manufacture): Original or Certified Copy or electronic version with confirmation link.
- 7.2. The Certificate of Quality (CQ) or Conformity issued by Manufacturer: the original or copy certified by the importer or electronic version with confirmation link.
- 7.3. Certificate of Offshore Product issued by VR for air winches in case they are manufactured in Vietnam or Certificate of product/Compliance/Conformity issued by one of the organizations under IACS such as ABS, BV, DNV... for air winches manufactured abroad: Original or electronic version with confirmation link.
- 7.4. Load test/ proof load test report 125% SWL issued by Manufacturer, witnessed by VR in case it is manufactured in Vietnam or IACS member such as ABS, BV, DNV...: Original or electronic version with confirmation link.
- 7.5. Seller's Certificate of Guarantee: Original

#### **8. METHOD OF EVALUATION FOR PROPOSALS**

- 8.1. Technical proposals will be evaluated by whole requisition in accordance to the "Technical Evaluation Criteria"



