

REQUEST FOR QUOTATION

No. PVEPNCS-26-10172

Issue to:

<u>RFQ Date:</u>		<u>Closing Date:</u>		<u>Currency:</u>	
<u>Delivery Date:</u>	31-Dec-2026 10:09 AM	<u>Quotation Validity (Days):</u>	90	<u>Delivery Terms:</u>	
<u>Quotation Language:</u>	English or Vietnamese	<u>Ship via:</u>		<u>Payment Terms:</u>	

Shipping Instruction:

PTSC Port.
65A, 30/4 Street, Rach Dua Ward,
Ho Chi Minh, S.R Vietnam.

Reply to:

PVEP-NCS Office
15th Floor - Victory Tower- 12 Tan Trao str, Tan My
Ho Chi Minh, Viet Nam

PVEP-NCS hereby solicits a most competitive Quotation proposal from your esteem company in accordance with the following requirements

Scope of supply

Line	Item	Description	Order Unit	Quantity	PR #
1		Service	LOT	1	26-10322
2		Main materials, Accessories, consumable.	LOT	1	26-10322

Special Conditions:

- *Standard Terms & Conditions are specified in accordance with the attachment herein shall apply*

- *Your official Quotation Proposal shall be signed by duly authorized representative, stamped and reached to us not later than the Closing Date.*

Signature:
Name:
Designation:
Date:



Verified by: One CA
Signed by: NGUYỄN XUÂN NINH
Signed date: 29/04/2026
09:03:05

Verified by CPM

Verified by Request Dept.



Nam, Tran Ngoc



Verified by: One CA
Signed by: TĂNG VĂN ĐÔNG
Signed date: 28/04/2026
10:54:08

Dong, Tang Van

PVEP-NCS'S GENERAL TERMS AND CONDITIONS FOR REQUEST FOR QUOTATION

ARTICLE 1 - PREAMBLE

- The SERVICE ORDER is issued by **Nam Con Son Petroleum Exploration Production Branch - PetroVietnam Exploration Production Corporation Limited** to SUPPLIER for the supply of SERVICES as specified herein and according to the Terms and Conditions of SERVICE ORDER.

ARTICLE 2 - DEFINITIONS

1. "AFFILIATES" means any CLIENT which controls, or is controlled by, or which is controlled by an entity, which controls, a Party. For the purposes of this definition, "control" means the ownership directly or indirectly of more than fifty (50%) percent of the voting rights in a CLIENT.
2. "CLIENT" means Nam Con Son Petroleum Exploration Production Branch - PetroVietnam Exploration Production Corporation Limited or any its divisions, AFFILIATES so named in the SERVICE ORDER.
3. "SERVICES" means all works, services and obligations to be performed, provided or otherwise fulfilled by SUPPLIER pursuant to and in accordance with the Terms and Conditions of the SERVICE ORDER, including without limitation the work and services described in the SERVICE ORDER, together with any operations carried out in connection therewith, and the physical result of the performance of such work, services and obligations.
4. "SERVICE ORDER" means the SERVICE ORDER form this document and any other documents listed herein and shall constitute the entire agreement between the Parties and the appendices as may be amended by any special conditions referred to in the SERVICE ORDER.
5. "SPECIFICATIONS" means the specifications of equipment, supplies and materials to be supplied by SUPPLIER together with the relevant data or other information relating to SERVICES, the specifications shall constitute an integral part of the SERVICE ORDER.
6. "SUPPLIER" means the person(s), firm, company or entities named in the SERVICE ORDER to supply SERVICES hereinafter defined and shall include the SUPPLIER's legal personal representatives, successors and assignees.

ARTICLE 3 - TIME OF THE ESSENCE

1. Time is of the essence with regard to SUPPLIER's performance under the Terms and Conditions of SERVICE ORDER. SUPPLIER shall begin performing SERVICES in accordance with the SERVICE ORDER and proceed diligently to complete SERVICES within the Terms and Conditions of SERVICE ORDER.
2. SUPPLIER (i) acknowledges and agrees that the Terms and Conditions of SERVICE ORDER is adequate for performance of the SERVICES, and (ii) understands that SUPPLIER's failure to complete the SERVICES within the Terms and Conditions of SERVICE ORDER will occasion loss and damage to CLIENT.
3. SUPPLIER shall give written notice to CLIENT of any anticipated delay. In case of actual or anticipated delay, CLIENT may terminate the SERVICE ORDER in manner as specified in the Article headed TERMINATION.
4. SUPPLIER shall be responsible for and bear all risks and relevant costs and damages and/ or loss caused to CLIENT arising out of or relating to SUPPLIER's breach of this Article.
5. SUPPLIER shall be responsible for any incremental installation cost and/ or transportation cost and/ or any other reasonable cost/ expenses resulting from late performance and/ or completion of SERVICES.

ARTICLE 4 - FORM OF SERVICE ORDER

1. CLIENT shall not be liable for any orders or amendments other than those issued or confirmed on CLIENT's official printed SERVICE ORDER and any amendment thereto.
2. CLIENT may make changes in the SPECIFICATIONS or drawings, including additions to or deletions from the quantities of SERVICES originally ordered. If any such changes affect the amount due and/or the time of performance hereunder, an equitable adjustment shall be made as mutually agreed by SUPPLIER and CLIENT, to the amount due and/or the time of performance, as the case may be by the issuance of CLIENT's Change Order.
3. Authorized Change Order requests made after placement of SERVICE ORDER shall be priced properly justified and immediately submitted to CLIENT for approval. CLIENT reserves the right to accept or reject any or all requests.

ARTICLE 5 - DEFECTIVE OR DEFICIENT OF SERVICES

1. If the performance of SERVICES is defective or deficient or SUPPLIER otherwise fails to perform SERVICES in accordance with the Terms and Condition of SERVICE ORDER (each such occurrence, a "Defect"), SUPPLIER shall, at its expense and within 48 hours' notice from CLIENT, correct any Defect and, to the extent incurred by CLIENT, pay or reimburse CLIENT for all labor and the actual delivered cost of all materials, equipment, and machinery required to correct the Defect. Any payments otherwise due to SUPPLIER shall be suspended until SUPPLIER corrects the Defect to CLIENT's satisfaction. If SUPPLIER fails to correct any Defect within 48 hours after receipt of written notice from CLIENT, CLIENT may, without prejudice to any other remedies CLIENT may have, (i) order SUPPLIER to stop performing any or all of the SERVICES, and/ or (ii) perform or reperform SERVICES, or engage a third party to do the same, with all costs incurred by CLIENT in connection with the performance or reperformance of SERVICES to be deducted from amounts otherwise payable to SUPPLIER. If amounts then or thereafter payable to SUPPLIER are insufficient to cover such costs, SUPPLIER shall pay the difference to CLIENT. If SERVICES are defective or deficient to the extent that it is not technically or economically feasible to correct such Defect, SUPPLIER shall be liable to CLIENT for all losses, damages, costs and expenses arising directly or indirectly from such Defect.
2. In case of SUPPLIER's failure under this Article shall be deemed a breach of the SERVICE ORDER and CLIENT reserves the right to terminate the SERVICE ORDER or refuse to accept SERVICES respectively.

ARTICLE 6 - EXPEDITING

1. CLIENT or its appointed third party shall have the right to visit SUPPLIER's mill and plant and those of Sub-SUPPLIER(s) for expediting purposes at any time prior to the commencement of SERVICES. SUPPLIER and its Sub-SUPPLIERS shall provide access to their works at all times to CLIENT or its appointed third party. SUPPLIER's Sub-orders must carry a note to this effect.
2. Expediting of the SERVICE ORDER and SUPPLIER's Sub-orders by CLIENT or its appointed third party does not relieve Sub-SUPPLIER(s) from their responsibilities to ensure that all Sub-orders are delivered to SUPPLIER's works or plant by the due date.

ARTICLE 7 - INSPECTION

1. CLIENT or its appointed third party shall have the right to inspect, witness tests and survey the quality of SERVICES at SUPPLIER's and its Sub-Suppliers' plants at any time during manufacturing of SERVICES. SUPPLIER is required to provide every facility for such right to CLIENT or its appointed third party. SUPPLIER's Sub-orders to its Sub-SUPPLIER(s) shall carry a note to this effect. SUPPLIER's failure to instruct Sub-SUPPLIER(s) of the right to CLIENT or its appointed third party to make plant visit for Quality Assurance purposes at any time prior to the commencement of SERVICES may result in rejection of SERVICES manufactured at Sub-SUPPLIER(s)' plants.
2. SUPPLIER shall include in all orders to Sub-SUPPLIER(s) those SPECIFICATIONS included with the SERVICE ORDER, which governs the manufacturing, or testing of SERVICES produced by each Sub-SUPPLIER(s). Such SPECIFICATIONS, data or other technical description shall be available for review by CLIENT or its appointed third party at the Sub-SUPPLIER's facility.
3. Should any inspected or tested SERVICES fail to conform to the SPECIFICATIONS, CLIENT may reject them and SUPPLIER shall either replace the rejected SERVICES or make all the alternations necessary to comply SPECIFICATIONS requirements free of cost to CLIENT.
4. CLIENT shall reserve right to inspect, test and, where necessary, reject SERVICES after the commencement of SERVICES and shall in no way be limited or waived by reason of SERVICES having previously been inspected, tested and passed by CLIENT or its appointed third party prior to the commencement of SERVICES.
5. Nothing in this Article shall in any way release SUPPLIER from any warranty or other obligations under the SERVICE ORDER.

ARTICLE 8 - SPECIFICATIONS CHANGES

1. CLIENT must be advised of all changes in the SPECIFICATIONS or method of construction of SERVICES supplied before such changes are implemented. In the event of CLIENT accepting the change, a written approval will be sent to SUPPLIER.

ARTICLE 9 - PAYMENT

1. SUPPLIER shall submit its invoice after SERVICES has been completed by SUPPLIER. Unless otherwise stated in the SERVICE ORDER, CLIENT shall subject to any dispute over the invoice make payment within forty five (45) days after receipt of SUPPLIER's undisputed invoice. If the forty fifth (45th) day falls on a Saturday or Sunday or a gazette S.R. Vietnam public holiday, the next working day shall be deemed to be the due date of payment.
2. Payments in respect of disputed items may be withheld by CLIENT until the settlement of the dispute by mutual agreement. Payments made by CLIENT shall not preclude the right of CLIENT to thereafter dispute any of the items invoiced.
3. In the event that CLIENT disputes any items on a particular invoice, CLIENT shall only be entitled to withhold from payment the actual amount in dispute. If CLIENT disputes any items on an invoice, CLIENT shall inform SUPPLIER of the disputed item within forty five (45) days of the receipt by CLIENT of that particular invoice.
4. CLIENT shall be entitled to withhold payment if any of SUPPLIER's invoices which do not include sufficient supporting documentation required by CLIENT.
5. SUPPLIER shall advise CLIENT on its account details and/or any changes to its account details if any by an at least 15 days in advance notice. Should SUPPLIER fail to give such notice in due time to CLIENT, SUPPLIER shall bear all risks associated with wrong/incorrect money transfer made by CLIENT.

ARTICLE 10 - TAXES AND DUTIES

1. SUPPLIER shall be responsible to pay all taxes, duties, assessments, royalties, fees or other charges levied by any government authorities of S.R. Vietnam or any other countries on account of or in relation to or in connection with the SERVICE ORDER and SUPPLIER shall indemnify and hold CLIENT harmless from and against any liabilities arising out of due to failure of SUPPLIER to fulfill this obligation.
2. CLIENT shall have the right to deduct sums from monies due to SUPPLIER hereunder for the aforesaid payment as required by law. Such withholding shall relieve CLIENT of further obligation with respect to any amount withheld.

ARTICLE 11 - SUSPENSION

1. CLIENT shall have the right to suspend the SERVICE ORDER for the following reasons: (i) Force Majeure as specified in the Article headed FORCE MAJEURE; (ii) in the event of any complete or partial stoppage of the relevant projects of CLIENT; (iii) failure on part of SUPPLIER to perform any obligation as per the SERVICE ORDER. Such suspension shall remain in force until such time that the above reasons are no longer applicable or otherwise when waived in writing by CLIENT.

ARTICLE 12 - TERMINATION

1. CLIENT may terminate the SERVICE ORDER at any time by giving written notice to SUPPLIER. Upon receipt of such notice, SUPPLIER shall cease supply of SERVICES and CLIENT shall pay SUPPLIER a fair price with proper supporting evidences for any SERVICES performed at the date when such notice is given. In case of such termination, SUPPLIER shall (i) use its best endeavors to effect the immediate cancellation of orders which it may have placed with others and discontinue all works of SERVICES, and (ii) upon CLIENT's request, deliver to CLIENT any or all the work, drawings, SPECIFICATIONS, data sheet and other matters that SUPPLIER may have prepared for the performance of SERVICES and all materials, supplies and equipment paid for by CLIENT either directly or in directly, and CLIENT shall have the right to make use of same for such purposes as CLIENT may desire, and (iii) not be entitled to any prospective profits or incidental, indirect, consequential or other damages because of termination.
2. In the event the CLIENT terminates the CLIENT ORDER in whole or in part in any of the following cases: (i) SUPPLIER's failure to meet the timing as specified in the Article headed TIME OF THE ESSENCE, (ii) SUPPLIER's failure to performance and/ or complete SERVICES as specified in the Article headed DEFFECTIVE OR DEFFICIENT OF SERVICES, SUPPLIER shall compensate CLIENT for all losses and/ or damages arising from such SUPPLIER's breach of SERVICE ORDER and shall pay to CLIENT the agreed and liquidated damages as stipulated Article headed LIQUIDATED DAMAGES. Payment for all compensation and agreed and liquidated damages shall be made to CLIENT within 10 (ten) days upon the CLIENT's first written request.

ARTICLE 13 - STANDARDS AND MATERIALS

1. SUPPLIER shall perform SERVICES in a thorough and workmanlike manner and to the satisfaction of CLIENT.
2. All workmanship, parts, materials, equipment and machinery furnished by SUPPLIER in connection with SERVICES must be of good quality, and new. SUPPLIER shall repair, or remove and replace, at SUPPLIER's own expense and at CLIENT's convenience, all workmanship, parts, materials, equipment or machinery that prove to be defective at any time within one year following satisfactory completion of SERVICES.

ARTICLE 14 - HEALTH, SAFETY AND ENVIRONMENT (HSE)

1. SUPPLIER shall be responsible for the HSE of all persons engaged in the performance of SERVICES and all persons who may be affected by activities of SUPPLIER and shall comply with all the HSE regulations and procedures.

ARTICLE 15 - WARRANTY

1. SUPPLIER represents, warrants and agrees that SERVICES performed by SUPPLIER shall be conducted and completed in conformity with all requirements of the Terms and Conditions of SERVICE ORDER and in a manner that complies with all the applicable laws, regulations, ordinances and codes.
2. CLIENT's inspecting, testing, witnessing tests, paying invoices or issuing any final acceptance shall not relieve SUPPLIER from its obligations set forth in this Article.

ARTICLE 16 - LIABILITIES AND INDEMNITIES

1. SUPPLIER shall be responsible for and shall protect, indemnify and save CLIENT harmless from and against any claims, demands and causes of action for damage to any property as well as death of and/or personnel injury to any person arising out of the act or omission to act, negligent or otherwise, of SUPPLIER, SUPPLIER's employees and SUPPLIER's agents in connection with the execution of the SERVICE ORDER.
2. SUPPLIER shall be liable for, indemnify and hold CLIENT (including CLIENT's officers, directors, employees or agents), harmless from all damages, claims, losses, expenses and/or reasonable attorneys fees including, but not limited to, suits or claims for damages for death, human bodily injury or other property resulting from any defects of SERVICES even if the quality of SERVICES conforms to the SPECIFICATIONS and has passed the inspection by CLIENT.

ARTICLE 17 - LIMITATION OF LIABILITY

1. Neither Party shall be liable to the other for any indirect or remote losses of any kind or for damages for loss of anticipated revenue or profits, nor any special, punitive, exemplary or consequential damages, including, but not limited to, loss of SERVICES, cost of capital, cost incurred in connection with labor, overhead, general administrative, transportation, substitute facilities, support sources or other similar damages.

ARTICLE 18 - INSURANCE

1. SUPPLIER shall procure and maintain, from an insurer acceptable to CLIENT, the insurance coverage described in this Article, as such coverage requirements may be modified by any additional or different coverage set forth in the SERVICE ORDER. Such insurance is to be primary with respect to any other similar insurance available to CLIENT, regardless of the provisions of such insurance, and is to name CLIENT and its AFFILIATES as additional insureds; provided, however, that any insured coverage, including, but not limited to, any additional insured coverage, will not include coverage to the extent that it constitutes a prohibited indemnity agreement under applicable law. All policies on which CLIENT and its AFFILIATES are additional insureds must include waivers of subrogation by the insurers in favor of CLIENT and its AFFILIATES. Prior to commencement of SERVICES, SUPPLIER shall furnish to CLIENT certificates and additional insured endorsements evidencing the specified insurance. If requested by CLIENT, SUPPLIER shall furnish to CLIENT certified copies of the insurance policies themselves. Such certificates must provide that at least 30 days' prior written notice of any policy cancellation or material change be given to CLIENT. Any losses, whether or not covered by the insurance described in this Article or within the deductible of such insurance, shall be the responsibility of SUPPLIER to the extent that such losses are covered by the provisions of Article headed LIABILITIES AND INDEMNITIES or any other provision of the Terms and Conditions of SERVICE ORDER.
2. SUPPLIER shall procure and maintain: (i) Workmen's Compensation Insurance covering personal injury to or death of the employees of the SUPPLIER engaged in the performance of SERVICES to the minimum value required by any applicable legislation including extended cover (where required) for working onshore and/ or offshore or such greater sum not less than one million US dollars (US\$1,000,000) per any one occurrence and unlimited in the aggregate; (ii) Public Liability Insurance for any incident or series of incidents covering the operations of SUPPLIER in the performance of SERVICES, in an amount not less than five million US dollars (US\$5,000,000) per any one occurrence and unlimited as to the number of claims in the period of insurance; (iii) any other insurance(s) which may be required CLIENT in the SERVICE ORDER or by law.

ARTICLE 19 - LIENS AND CLAIMS

1. SUPPLIER shall indemnify and hold CLIENT harmless from all liens, claims, assessments, fines and levies created, caused or committed by SUPPLIER or by its Sub-SUPPLIER(s) and all costs, damages and expenses incidental thereto, including without limitation all court and arbitration costs, attorney's fees and other reasonable expenses.

ARTICLE 20 - FORCE MAJEURE

1. Neither SUPPLIER nor CLIENT shall be liable to other Party for any breach of the Terms and Conditions of the SERVICE ORDER where such breach occurs as a result of a Force Majeure.
2. The events falling within Force Majeure include but are not limited to Acts of God or force of nature, landslide, lightning, earthquake, flood, fire, explosion, storm or storm warning tidal wave, shipwreck and perils to navigation, act of war (declared or undeclared) or public enemy, strike act (excluding strikes, lockouts or other industrial disputes or action solely amongst employees of SUPPLIER or its sub-SUPPLIER(s) or omission of sovereign states or those purporting to represent sovereign states, blockade, embargo, quarantine, public disorder, sabotage or similar events beyond the control of the Parties or either of them. Force Majeure shall exclude financial distress on the part of SUPPLIER or its sub-SUPPLIER(s).
3. Subject to the above, a Party claiming the benefit or protection of this Article, without delay, takes all reasonable steps to remove its inability to comply with the provisions of the SERVICE ORDER.

ARTICLE 21 - AMENDMENTS

1. CLIENT and SUPPLIER shall mutually agree in writing to any amendments to the SERVICE ORDER. In the event of any conflict or inconsistency between the Terms and Conditions of the SERVICE ORDER and the attachments to the SERVICE ORDER, the Terms and Conditions of SERVICE ORDER shall prevail.

ARTICLE 22 - ASSIGNMENT AND SUBCONTRACTING

1. CLIENT shall not be liable for any orders other than those issued or confirmed on the CLIENT's official written SERVICE ORDER or any amendment thereto. SUPPLIER shall not assign or subcontract any part of the SERVICE ORDER, without the prior written approval of CLIENT. Un-priced copies of any such orders should be supplied to CLIENT on request. SUPPLIER shall procure for CLIENT the right to enter the sub-contractor's premises for the purpose of expediting and inspection.

ARTICLE 23 - CONFIDENTIALITY

1. Any SERVICE ORDER placed by CLIENT shall be treated as confidential and in particular SUPPLIER shall not make use of CLIENT's name or the name of any companies associated with CLIENT for publicity purposes without the prior written consent of CLIENT. Furthermore, all designs, drawings, SPECIFICATIONS and information which may be supplied in connection with the SERVICE ORDER are confidential and must only be used for the purpose of the SERVICE ORDER.
2. No public statements, announcements or circulars regarding the SERVICE ORDER or the activities of the Parties relating thereto shall be made or issued by or on behalf of SUPPLIER without the prior written approval of CLIENT.

ARTICLE 24 - PATENT INDEMNITY

1. SUPPLIER shall indemnify CLIENT against any claim of infringement of patents, registered designs or other rights which arise as a result of the sale or use of SERVICES supplied by SUPPLIER. This indemnity shall not extend to instances in which SERVICES concerned have been supplied to CLIENT.
2. SUPPLIER is obliged to secure that the ownership rights to SERVICES are not disputed by a third party. In case there is any dispute by a third party, SUPPLIER shall take side with CLIENT in order to protect CLIENT's interests. If the third party is entitled to own part or the whole of SERVICES, CLIENT shall be entitled to cancel the SERVICE ORDER and SUPPLIER shall compensate CLIENT for all damage including, but not limited to the refund of SERVICE ORDER price, liquidated damage, legal cost, and attorney fees.

ARTICLE 25 - VENDOR DATA REQUIREMENTS AND SUBMITTAL

1. Drawings and vendor data are to be submitted in strict compliance with the SPECIFICATIONS. If for any reason, the transmission of drawings and vendor data shall be delayed, CLIENT is to be informed immediately in writing, giving reason in for such delay. All drawings and vendor data shall be delivered to CLIENT by hand or through courier service. All preliminary, intermediate and final drawings and vendor data to be furnished shall be subjected to expediting by CLIENT or its appointed SUPPLIER.

ARTICLE 26 - LIQUIDATED DAMAGES

1. Should SUPPLIER fail to (i) meet the timing as specified in the Article headed TIME OF THE ESSENCE and/ or (ii) performance and/ or complete SERVICES as specified in the Article headed DEFFECTIVE OR DEFFICIENT OF SERVICES, SUPPLIER shall have to pay CLIENT the agreed and liquidated damages at the rate of 2 % (two percent) of the SERVICE ORDER value per week of delay in performance or in replacement or repair up to maximum of 8% (eight percent) of the SERVICE ORDER value.
2. The rate of agreed and liquidated damages is not subject to any alteration by Arbitration or any third parties. The amount of agreed and liquidated damages may be deducted by CLIENT from SUPPLIER's Invoices while effecting the payment. Should CLIENT fail to deduct the sum of money of agreed and liquidated damages from the SUPPLIER's Invoice, SUPPLIER shall have to pay it immediately but not later than ten (10) days upon the CLIENT's first written request.

ARTICLE 27 - SPECIAL CONDITIONS

1. Where special conditions are set forth on the front of the SERVICE ORDER, those conditions shall apply equally with the general conditions shown above except that where there is any inconsistency between the general and special conditions the special conditions shall apply.

ARTICLE 28 - APPLICABLE LAW AND ARBITRATION

1. The SERVICE ORDER and all questions concerning its formation, validity, interpretations and performance shall be governed under the Laws of the S.R. Vietnam.
2. Any disputes arising out of or in connection with any SERVICE ORDER which could not settled through negotiation between the two Parties shall be finally settled by the Vietnam International Arbitration Center (VIAC) besides Vietnam Chamber of Commerce and Industry (VCCI) under VIAC Arbitration Rules for final settlement. The place of Arbitration shall be in Ho Chi Minh City, Vietnam. The Arbitral Board shall be three (3) arbitrators and the language of Arbitration shall be English. The costs of Arbitration shall be borne by the lost Party. The award made in accordance with the provisions of this Article shall be final and binding upon two Parties.

ARTICLE 29 - LANGUAGE

1. All documents produced by SUPPLIER in the performance of the SERVICE ORDER as well as all written communications between CLIENT and SUPPLIER shall be written in the English language which is hereby designated the governing language of the SERVICE ORDER. SUPPLIER and CLIENT may use any language within their own organizations, except that all Sub-contracts and all written communications pertaining to them shall be in English.

ARTICLE 30 - ENTIRE AGREEMENT

1. The Terms and Conditions set out herein, together with any subsequent amendments made in accordance with Article headed FORM OF SERVICE ORDER and any and all designs, drawings, SPECIFICATIONS and information which may be supplied in relation to the SERVICE ORDER represent the entire Terms and Conditions of the SERVICE ORDER between CLIENT and SUPPLIER. Failure of either Party to enforce any of the Term and Conditions of the SERVICE ORDER shall not prevent a subsequent enforcement of such Terms and Conditions or be deemed to be waiver of any subsequent breach. Should any provision of the SERVICE ORDER, or a portion thereof, be unenforceable or in conflict with governing country, state, province, or local laws, then the validity of the remaining provisions, and portions thereof, shall not affected by such unenforceability or conflict, and the SERVICE ORDER shall be construed as if such provisions, or portion hereof, were not contained herein.
2. None of the provisions of the SERVICE ORDER shall be considered waived by CLIENT, except when waived explicitly in writing and notified to SUPPLIER. No such waiver shall be, or shall be construed to be, a waiver of any past or future default or breach, nor constitute a modification of any of the terms, provisions, conditions, or covenants of the SERVICE ORDER, except as expressly stated in such waiver.

BID SUBMISSION FORMAT

1. PROPOSAL FORMAT

- 1.1 BIDDER is to strictly adhere to the proposal format as set out below. **BIDDER must ensure that the "TECHICAL UNPRICED (TECHNICAL)" does not contain any pricing or cost.** *Failure to comply with these instructions may render BIDDER's proposal invalid.*
- 1.2 BIDDER is to submit the proposal in One (01) separate sealed package, with two (02) parts as follows:
- a) Technical Unpriced (Technical)
 - b) Priced (Commercial)
- 1.3 CONTENTS OF TECHNICAL UNPRICED (TECHNICAL)
- Unpriced package shall include but not limited to the following:

SECTION	CONTENT
Section 1	<p>PROPOSAL LETTER</p> <p>The Proposal Letter shall be prepared and fully filled by BIDDER and must be signed by the authorized representative of BIDDER (the representative at law of the BIDDER or the authorized person with legal Power of Attorney). In case of authorization, BIDDER shall enclose the following instruments and documents to prove the legitimacy of the authorized person:</p> <ul style="list-style-type: none">a. In case of independent BIDDER: Power of Attorney signed by the Representative at law of BIDDER authorizing the authorized person to sign the Proposal Letter;b. In case of Consortium: Proposal Letter shall be signed by the Representative at law of each Consortium Partner, unless the Consortium Agreement stated that the Consortium Partners have authorized the representative at law of Leading Partner of the Consortium to sign Proposal Letter. If each Consortium Partner has authorized such Representative, the same requirements as independent BIDDER shall be applied.
Section 2	<p>BIDDER'S ELIGIBILITY, EXPERIENCES & CAPACITY <i>(not applicable for this RFQ)</i></p> <p>BIDDER shall provide the following documents proving BIDDER's eligibility, experiences, and capacity:</p> <ul style="list-style-type: none">(i) BIDDER's Organization(ii) BIDDER's Experience;(ii) Company Profile; <p>BID BOND <i>(not applicable)</i></p>

SECTION	CONTENT
	BIDDER shall provide the Original Bid Bond as Form attached here-with.
Section 3	<p>TECHNICAL PROPOSAL</p> <p>BIDDER shall provide the following documents to prove the suitability (compliance) of WORKS/SERVICES:</p> <ol style="list-style-type: none"> 1. BIDDER is to provide (i) the detailed description of the working procedures, BIDDER's capability of the WORKS proposed and (ii) the relevant guidelines, drawings, certificates, records to provide the Scope of Works as specified in Request for Quotation; 2. BIDDER is to submit the information as – EQUIPMENT, MATERIALS, SUPPLIES AND SERVICES TO BE PROVIDED BY CONTRACTOR (if any); 3. Curriculum Vitae (CV) of Proposed Manpower as set out in BIDDING FORMS (if any);
Section 4	<p>BIDDER'S UNPRICED EXCEPTIONS AND ALTERNATIVES</p> <ol style="list-style-type: none"> a. If BIDDER has no exception and alternative proposal, BIDDER shall have the following statements prominently displayed in capital letters under this section: "THIS PROPOSAL COMPLIES WITH ALL TERMS AND CONDITIONS OF THIS CONTRACT, EXHIBITS AND REQUIREMENTS IN THIS RFQ" or b. If BIDDER has alternative proposal on this bid documents, BIDDER shall display the following statement in capital letters under this section: "THIS PROPOSAL INCLUDES EXCEPTIONS AND ALTERNATIVES WHICH ARE LISTED ON THE FOLLOWING PAGES." c. BIDDER shall present a complete and detailed listing of non-compliance to the RFQ in total indicating the delivery impact only, if any, but without indicating the cost impact. The format of presentation shall be as per the attached BIDDER's EXCEPTION TO TERMS AND CONDITIONS and BIDDER's EXCEPTION TO EXHIBITS.

1.4 CONTENTS OF PRICED (COMMERCIAL)

Every page of BIDDER's price proposal must bear BIDDER's company seal. Priced package shall include the following:

SECTION	CONTENT
Section 1	<p>PROPOSAL LETTER</p> <p>As attached here-with.</p>
Section 2	<p>BIDDER is requested to submit the following with prices & schedule attached Request for Quotation No. PVEPNCS-xxxxx.</p>

Section 3	<p>BIDDER's PRICED EXCEPTIONS AND ALTERNATIVES.</p> <p>a. If BIDDER has no exception and alternative proposal, BIDDER shall have the following statements prominently displayed in capital letters under this section: "THIS PROPOSAL COMPLIES WITH ALL TERMS AND CONDITIONS OF THIS CONTRACT, EXHIBITS AND REQUIREMENTS IN THIS RFQ" or</p> <p>b. If BIDDER has alternative proposal on this bid documents, BIDDER shall display the following statement in capital letters under this section: "THIS PROPOSAL INCLUDES EXCEPTIONS AND ALTERNATIVES WHICH ARE LISTED ON THE FOLLOWING PAGES."</p> <p>BIDDER shall present a complete and detailed listing of non-compliance to the RFQ in total indicating the delivery impact and cost impact, if any. The format of presentation shall be as per the attached BIDDER's EXCEPTION TO TERMS AND CONDITIONS and BIDDER's EXCEPTION TO EXHIBITS as set out in BIDDING FORMS.</p>
-----------	--

2. SUBMISSION OF PROPOSAL

2.1 Technical Unpriced (Technical) and Priced (Commercial) shall consist of:

- a) **One (1) original and one (1) copy** of each part wrapped separately and clearly marked with the word "TECHNICAL UNPRICED" or "COMMERCIAL PRICED" on the cover of the respective wrapping and All put together in one (1) big package with title in item 2.7.
- b) 01 native copy containing Technical Unpriced (Technical) and 01 native copy containing Priced (Commercial) with label having BIDDER name, Tender title and number (if any). The native copy shall be wrapped and sealed separately and marked with the word "**UNPRICED PACKAGE**" or "**PRICED PACKAGE**" on the covers of the packages. The soft Proposal documents shall be in native file format (Microsoft Word® and Microsoft Excel®) - **(not applicable)**.

In the event of discrepancy between the original set and the copies, the original set shall prevail.

2.2 BIDDER shall ensure that all proposals or submissions to CLIENT, pertaining to the enquiry are properly sealed and that the cover of each package is clearly marked in **bold letters** with the following wordings:

- (a) RFQ number and the title.
- (b) BIDDER's name and return address.
- (c) "TECHNICAL UNPRICED PACKAGE" or "PRICED PACKAGE".
- (d) "PRIVATE AND CONFIDENTIAL"

2.3 **All communications and correspondence with regard to RFQ and clarification shall be made to the following address:**

**NAM CON SON PETROLEUM EXPLORATION PRODUCTION BRANCH -
PETROVIETNAM EXPLORATION PRODUCTION CORPORATION LIMITED**
15th Floor, Victory Tower, 12 Tan Trao Street, Tan My Ward, Ho Chi Minh City, S.R Vietnam
Tel: (84-28) 3776 2222 Fax : (84-28) 3872 1079 / 3872 1088
Attention: **Contract & Procurement Department Manager**

All communications with regard to bid clarifications shall be made in writing and must indicate the RFQ number and title and send to the address given above. Such bid clarifications shall reach the address given above **at least five (05) days** prior to the Bid Closing Date. CLIENT shall preserve the right not to respond to bid clarifications received later than the above-mentioned time.

For any further information, please contact email: anhnd-tmdt@pvcp.com.vn

Submission of Quotation Proposal shall be made to the following address:

**NAM CON SON PETROLEUM EXPLORATION PRODUCTION BRANCH -
PETROVIETNAM EXPLORATION PRODUCTION CORPORATION LIMITED**

15th Floor, Victory Tower

12 Tan Trao Street, Tan My Ward

Ho Chi Minh City, S.R Vietnam

Tel: (84-28) 3776 2222 Fax : (84-28) 3872 1079 / 3872 1088

Attention: **Contract & Procurement Department Manager**

- 2.4 BIDDER is strongly advised to deliver the proposals by hand in order to assure timely receipt by CLIENT. If BIDDER elects to mail the proposal, BIDDER is advised to use a fast and reliable delivery service e.g. courier. BIDDER should advise CLIENT by fax the date on which the proposal was mailed and details of the delivery service (if applicable).
- 2.5 Responsibility for timely delivery of the proposals to the correct address rests fully with BIDDER. CLIENT does not accept late bids submission. Delivery to the wrong address shall not be an excuse for late delivery.
- 2.6 BIDDER must ensure that the proposal is delivered to the address given in Item 2.3 above no later than the **bid closing date specified on the website “muasamcong.mpi.gov.vn” for this RFQ, LATE BIDS WILL NOT BE ENTERTAINED.**
- 2.7 BIDDER’s proposal shall be submitted in a **separate sealed envelope or package** bearing the name of your company, clearly addressed and marked on the outside as follows:

"STRICTLY CONFIDENTIAL"

[tender title]

(RFQ No.: PVEPNCS-xxxx)

- 2.8 Bid Proposal as well as all correspondences and documents relating to the RFQ exchanged by BIDDER and CLIENT shall be written in English. Supporting documents and printed literature furnished by BIDDER may be in another language provided they are accompanied by an accurate translation of the relevant passages in English, in which case, for purposes of interpretation of the Bid Proposal, the translation shall govern.
- 2.9 Proposal by BIDDER shall be binding for a minimum period of **90 calendar days from the Bid Closing Date**. BIDDER may assume that the award for Contract will be made within **90** calendar days from the Bid Closing Date and BIDDER can assume that it has not been successful if no notification is received within the bid validity period. BIDDER shall state the precise date of validity

in the proposal. CLIENT shall be entitled to request BIDDER to extend Bid Validity for maximum of 60 calendar days (if any) without any BIDDER's exception.

- 2.10 The proposed CONTRACT PRICE shall indicate whether it is inclusive of Vietnamese taxes (VAT, CIT, etc.) or not. In the event that the quoted prices do not specify this, they shall be treated as inclusive of all taxes.

3. ACCEPTANCE

- 3.1 CLIENT may, at CLIENT option, reject all proposals received or may accept any proposal which, in CLIENT's sole judgment, is the most advantageous to CLIENT. CLIENT reserves the right to accept or reject all or part of the proposal at CLIENT's discretion and will be under no obligation to explain the reasons thereof.
- 3.2 **Award Strategy: Single Award.** CLIENT reserves the right to award the CONTRACT at its own discretion.
- 3.3 CLIENT shall not be deemed to have accepted all or any part of a proposal unless and until a written acceptance is issued.
- 3.4 Any award as a result of this RFQ will be through a properly executed contract issued by CLIENT. Prior to this, CLIENT may send the BIDDER a Letter of Award in order to initiate immediate placement of order. Upon receipt of the Letter of Award, BIDDER shall proceed immediately with the work mentioned in the Letter of Award.
- 3.5 Bidder with any contract performance failure record with PVEP POC within 24 previous months from the date of issuance of this RFQ shall be excluded from the bidding of this RFQ.
BIDDER participating in bid must be legally and financially independent with Investor and/or Procuring Entity. Failure to comply with such a requirement may be considered as disqualifying.

4. PAYMENT

- 4.1 Payments shall be made in accordance to **Article headed as INVOICING AND PAYMENT** of Contract Form attached hereto.
- 4.2 Any proposal on progress payments shall be based on "value received" or verifiable milestones and not merely the passage of time and not for merely placing the Contract.

END OF SECTION

PROPOSAL LETTER FORM

Letterhead of BIDDER

Date:

To **NAM CON SON PETROLEUM EXPLORATION PRODUCTION BRANCH -
PETROVIETNAM EXPLORATION PRODUCTION CORPORATION LIMITED**

Attn: Director

Subject: RFQ for the [tender title]
RFQ No.: xxxx

Dear Sir ,

We, the undersigned, certify that we have read and understood the subject Invitation to Bid and all documents forming the Bid Document.

We acknowledge that we have thoroughly investigated, or have had the opportunity to do so, and satisfied ourselves as to all conditions affecting the GOODS/ SERVICES and all necessary information as to risk contingencies and all circumstances influencing and affecting this Bid Document.

We offer to supply the GOODS/ SERVICES as detailed in the Bid Package for the prices stated in our Proposal attached hereto. This offer is **valid until 90 days** from the date fixed for submitting same and shall be binding upon us and may be accepted at any time before the aforesaid date.

If our proposal is accepted, we undertake that, unless and until a formal CONTRACT is prepared and executed, this Bid Proposal, together with your written acceptance shall constitute a binding contract between us.

Yours faithfully

Correspondence from CLIENT should be
addressed to:

Signature :

Address :

Printed Name :

Attn :

Position :

Telephone :

Company:

Telex :

Date :

Fax:

BID BOND FORM

(not applicable)

Letterhead OF BANK

BID BOND TO RFQ No. xxxxxx

Date: _____

**To: NAM CON SON PETROLEUM EXPLORATION PRODUCTION BRANCH -
PETROVIETNAM EXPLORATION PRODUCTION CORPORATION LIMITED**

(hereinafter referred to as the "CLIENT")

Basing on the fact that _____ *[name and registered head office address of the BIDDER]*, (hereinafter referred to as "BIDDER"), will participate to the Bidding for your RFQ No. PVEP POC-xxx for the [tender title].

We _____ *[name of the BANK]*, having registered office located at _____ *[address of registered office of the BANK]* (hereinafter referred to as "BANK"), pledge to BIDDER to secure for the Bidder to participate in bidding for said RFQ with an amount ofVND *(In words: Vietnam Dong)* *[as stipulated on website]* We shall immediately transfer to CLIENT the amount of money mentioned above when CLIENT notifies in writing that Bidder breaks the requirements specified in the RFQ documents⁽¹⁾.

This Bid Bond is valid for 120 days from the bid closing date. Any claim of CLIENT related to this Bid Bond shall be received by *[name of the BANK]* before expiry of above mentioned validity period.

Legal Representative of the BANK

[Specify name, title, sign and seal]

Notes:

⁽¹⁾ *If the Bidder is a Consortium and the Consortium Partners provide separate Bid Bond or one Consortium Partner provides Bid Bond for the entire Consortium, then this requirement will be amended as follows: "We shall immediately transfer to CLIENT the amount of money mentioned above when CLIENT notifies in writing that BIDDER or any Partner in BIDDER's Consortium breaks the requirements specified in the RFQ documents".*

LICENSE FOR SALE OF THE MANUFACTURER FORM (if any)

Date: _____

To: **NAM CON SON PETROLEUM EXPLORATION PRODUCTION BRANCH -
PETROVIETNAM EXPLORATION PRODUCTION CORPORATION LIMITED**

(hereinafter referred to as the "CLIENT")

Dear Sir,

Basing on the request by _____ [*name of the BIDDER*] (hereinafter referred to as "BIDDER") who participates in bidding for RFQ No. xxxxx for the [tender title].

We _____ [*name of the MANUFACTURER*], incorporated on _____ [*specify the date of incorporation of the Manufacturer*], are producing _____ [*list of GOODS to be supplied*] and have registered address at _____ [*address of the MANUFACTURER*], hereby authorize BIDDER to use the products manufactured by us to offer in its RFQ.

We confirm that we will supply the all above GOODS to BIDDER for further supply to CLIENT and provide warranty for the GOODS under the Supply Contract signed between CLIENT and BIDDER.

Legal Representative of the MANUFACTURER

[Specify name, title, sign and seal]

Notes:

- (1) *Manufacturer's Authorization is applicable only for GOODS which are specific, sophisticated, if necessary, CLIENT may request such Letter.*

#

TECHNICAL REQUIREMENTS

1. INTRODUCTION

NAM CON SON PETROLEUM EXPLORATION PRODUCTION BRANCH – PETROVIETNAM EXPLORATION PRODUCTION CORPORATION LIMITED

(Hereinafter referred to as “PVEP-NCS”) is undertaking Petroleum activities for various PSC Block(s), Offshore Vietnam.

The Dai Hung oilfield located in Block 05-1A, offshore Vietnam and approximately 250 km from the coast of Vietnam at a water depth of approximately 110 meters. Currently Dai Hung Oilfield is operated by PVEP-NCS which is a branch of Petro Vietnam Exploration Production Corporation.

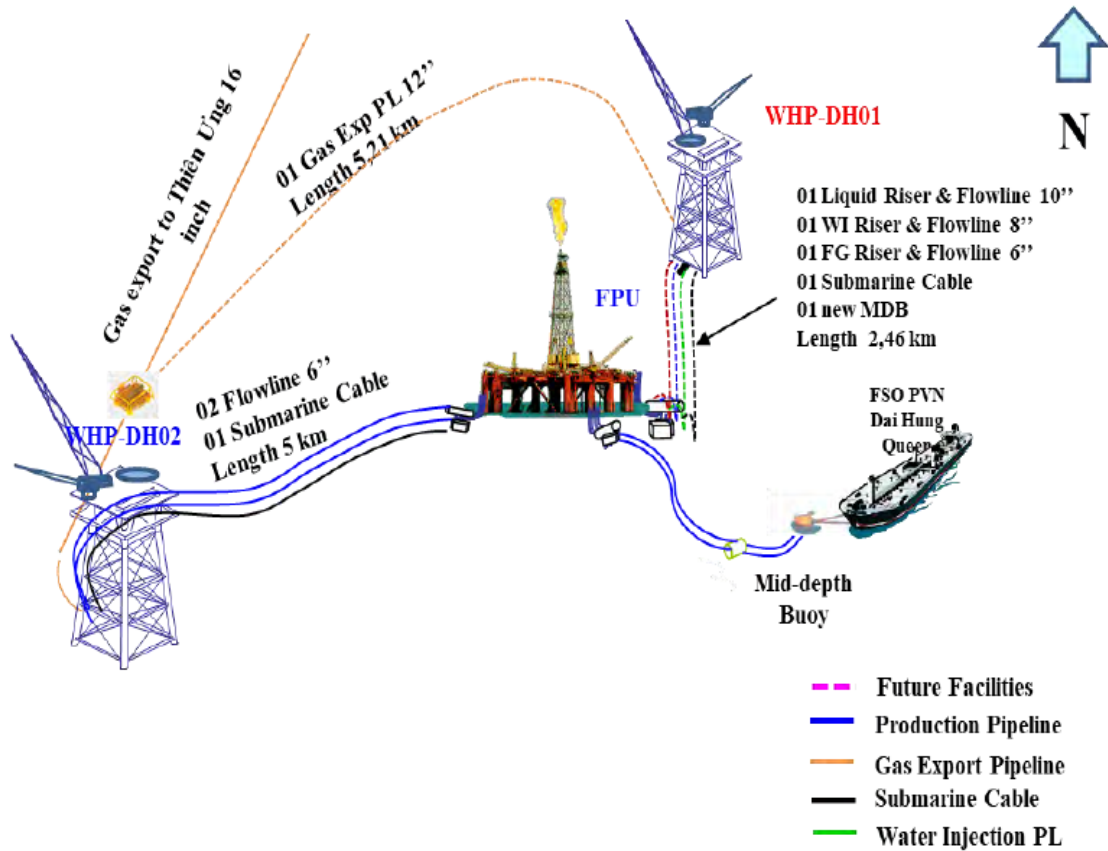

Figure 1: Dai Hung Overall Field Layout

As normal maintenance duty, PVEP - NCS is looking for Contractor to Supply “SERVICE TO UPGRADE NITROGEN SKID SYSTEM ON DH-01 FPU”.

2. EXISTING NITROGEN SKID

a. Nitrogen Generation System Configuration:

- Two nitrogen generation vessels: capacity 950 L each, design working pressure 8.5 bar.
- One nitrogen storage vessel: capacity 950 L, working pressure 8.5 bar, operating temperature range -27°C to 30°C.
- Pressure Safety Valves (PSVs) for overpressure protection of vessels and piping.
- Check valves to prevent backflow and pressure regulators for pressure control.

- Pneumatically actuated control valves.
- Pressure indicators/gauges.
- Air filtration unit for plant air, with a volume of 6.5 L and working pressure of 14 bar.
- Electrical solenoid valves.
- Control panel.
- One Pressure Switch Low (PSL) installed upstream of the nitrogen generation vessels to transmit a **low feed pressure alarm** to the control panel; one PSL installed downstream of the nitrogen storage vessel to transmit a **low product pressure alarm** to the control panel.

b. Operating Principle of the Nitrogen Generation System:

Plant air is supplied through an air filtration unit to remove impurities before entering the two nitrogen generation vessels (protected against overpressure by PSVs set at 9.5 bar).

These two vessels operate based on a **backwash (regeneration) principle**, with pneumatically actuated valves controlled by electrical solenoid valves to alternate operation.

The generated nitrogen is then directed to the nitrogen storage vessel (also protected by a PSV set at 9.5 bar) for distribution to end-user systems requiring nitrogen supply.

c. Controls.

✓ *Normal operation.*

The Nitrogen Generator operates automatically with all control function carried out with the control panel. Control panels were equipped the PLC to control the system and Oxygen sensor, Oxygen indicator to monitor the percentage of Oxygen in products nitrogen.

Power to control panel on start-up is available once the initial air purging is complete. The air purge is control by the purging system. It is independent with control system.

The control function is affected by two components within the control panel, the PLC and Oxygen analyzer.

- The PLC:
 - Control the sequence cycle on system.
 - Oxygen percentage indicator:
 - Indicate the oxygen concentration in the sample gas.
 - Low nitrogen pressure indicator:
 - This facility has been disabled on the sequence of PLC. Low feed and low product pressure are monitored independently of the PLC by two pressure switches both locally, by two lamp alarms on panel door, and remotely.
 - High Oxygen level indicator:
 - when first switch on the generator, takes a while to settle down to producing steady nitrogen purity. When the oxygen percentage has reached the set value the product will be available. The “High alarm” indicator will on whenever the oxygen concentration of sample gas tested is over set value. The set value is adjusted in the indicator. See the indicator instruction manual for detail.

✓ *Abnormal operation*

The following adjustments are not needed for normal plant operation but may be useful during commissioning or when the plant is being set up for duties other than the design case.

Alarm level.

The alarm level is typically 3% of oxygen. And automatically close the production valve when the oxygen percentage is higher than 3%.

The setting alarm level can be adjusted in the oxygen indicator. See instruction manual for details.

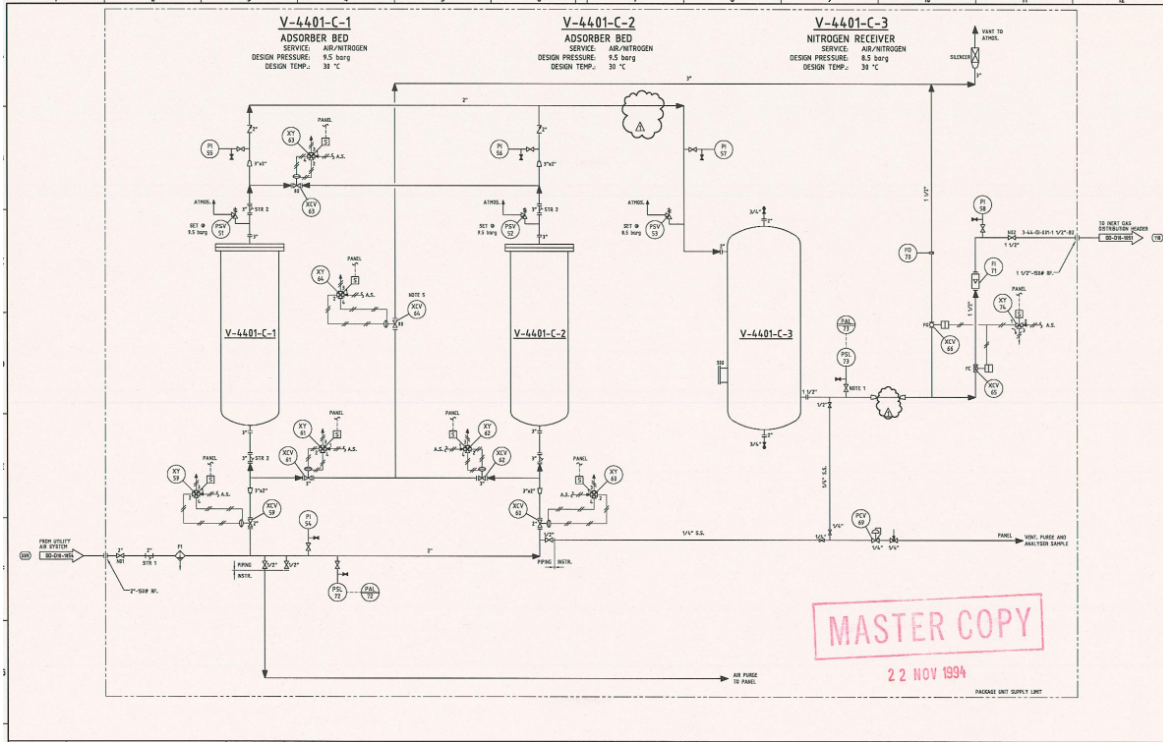

Figure 2: P&I Diagram - Nitrogen System on DH-01 FPU

3. TECHNICAL REQUIREMENTS

Provides manpower, equipment, materials for renew controller, I/O modules, HMI, programming to make sure it operates full function as old system. Overhaul all control valves, PCVs, refurbish control cabinet of the Nitrogen skid.

The scope of work shall include, but not limited to the following:

No.	Description	Model/PN	Maker	Qty	Unit
A	Main material				
1	Oxygen analyzer -N2 Capacity: 150 Nm3/h @ 3% oxygen - Nitrogen purity: >= 97% - Temperature: - Ambient N2 Dew Point: -40 DegC		EMERSON/ Rosemount	1	Package
2	- PLC, IO Modules, HMI, power supply, base unit.		SIEIMENS or Equivalent	1	Package

No.	Description	Model/PN	Maker	Qty	Unit
B	Accessories				
1	Contactors, relays...			1	Lot
C	Consumable materials (Instrument cable, terminal, Junction box, cable gland)				
				1	Lot
D	Service & Manpower				
5	- Site survey (If necessary)			1	Lot
6	Onshore activities, included but not limited: - Design Hardware and Programming - HMI Design - Factory Acceptance Test			1	lot
7	Offshore activities, included but not limited: - Configuration - Refurbished control cabinet - Installation - SAT - Overhaul control valves & pressure control valves. - Commissioning and handover - Work completement.			1	lot

- VENDOR should be going to site to survey (If necessary).
- VENDOR shall supply the main material, CO/CQ: Original
- Goods must be brand new and 100% unused.

4. VENDOR RESPONSIBILITIES

- ✓ Bidder completed at least 01 offshore project with minimum scope of work as provision of material and service.
- ✓ Project Manager has worked for at least 5 years in Oil and Gas industry.
- ✓ Supply of all manpower and necessary to meet technical requirement specification including commissioning/start-up.
- ✓ Vendor shall supply all items for service, including any special equipment and tools for testing, calibration and maintenance purposes.
- ✓ All service activities must follow safety regulations at Dai Hung field.
- ✓ Vendors should provide personal safety equipment for their employees.

5. PVEP-NCS RESPONSIBILITIES

PVEP-NCS will send engineer to participate in all project activities (*project meetings respond to VENDOR's request for documentations, support site survey, ...*).

Project duration

- ✓ Delivery time: 22 weeks from the date of signing the contract.

- ✓ The duration of service on DH-01 FPU is no longer than 35 working days. (include preparing time)

DOCUMENTATION

- ✓ The vendor shall supply all related drawings.
- ✓ Vendor shall supply Site Acceptance Test Procedure.
- ✓ The vendor shall supply the documentation, original program.
- ✓ Certificate of Guarantee: 12 months from the date of signing the acceptance protocol.

TECHNICAL CRITERIA

No	CONTENTS	CRITERIA
A	COMPANY PROFILE	
1	Certificate of Business Registration suitable for industry automation/electrical domain.	Major
2	Provide a list of similar projects and services (at least 01 similar project on industry automation/electrical domain)	Major
3	CV of Project Manager (at least 5 years' experience in industry automation/electrical domain).	Major
4	Site supervisor has at least 5 years and site Engineer has at least 3 years working in Oil and Gas industry.	Major
B	TECHNICAL REQUIREMENTS	
1	Provides manpower, equipment, materials for renew controller, I/O modules, HMI, programming to make sure it operates full function as old system. Overhaul all control valves, PCVs, refurbish control cabinet of the Nitrogen skid.	Major
2	Supply all necessary material as specified in section 3 "Technical Requirements" of this document.	Major
4	Main materials must be brand new, 100% unused.	Major
5	Duration for installation and commissioning on DH-01 FPU is no longer than 35 working days, including preparing time (depending on the mobilization schedule and the working condition at site has confirmed by of PVEP -NCS).	Major
C	ORTHER REQUIREMENTS	
1	Main material delivery time: 22 weeks	Major
2	Certificate of Origin and Certificate of Quality: original for main material.	Major
3	Certificate of Warranty 12 months.	Major

SCHEDULE OF RATES PRICE

No.	Description	Quantity	Order Unit	Unit Price (VND)	Total Price (VND)
A	Service to Upgrade controller for Nitrogen skid on DH-01 FPU				
1	- Khắc phục các tồn đọng sau UWild 2025 – Electric & Instrumentation. - Nâng cấp bảo dưỡng hệ thống điều khiển Inert Gas Generator	1	Lot		
2	Phụ tùng cần cầu	1	Lot		
Total Price - DAP PVEP-NCS's warehouse at PTSC port, Vung Tau City, S.R. VIETNAM (INCOTERM 2020) Excl. VAT					
Estimated VAT %					
TOTAL Bid Price – Incl. VAT					

Note:

Above-mentioned total value of goods shall be proposed bid-winning price and contract price.

VAT are estimated at the time of PO signing. VAT shall be updated and applied according with current regulations at the time of invoice issuance.

Payment document:

- 1) Payment request (Original);
- 2) Invoice (Original);
- 3) Acceptance protocol approved by CLIENT (original);
- 4) Certificates as required in “TECHNICAL REQUIREMENTS”.

B 721-107 REV3
DRG. No. B 721-107

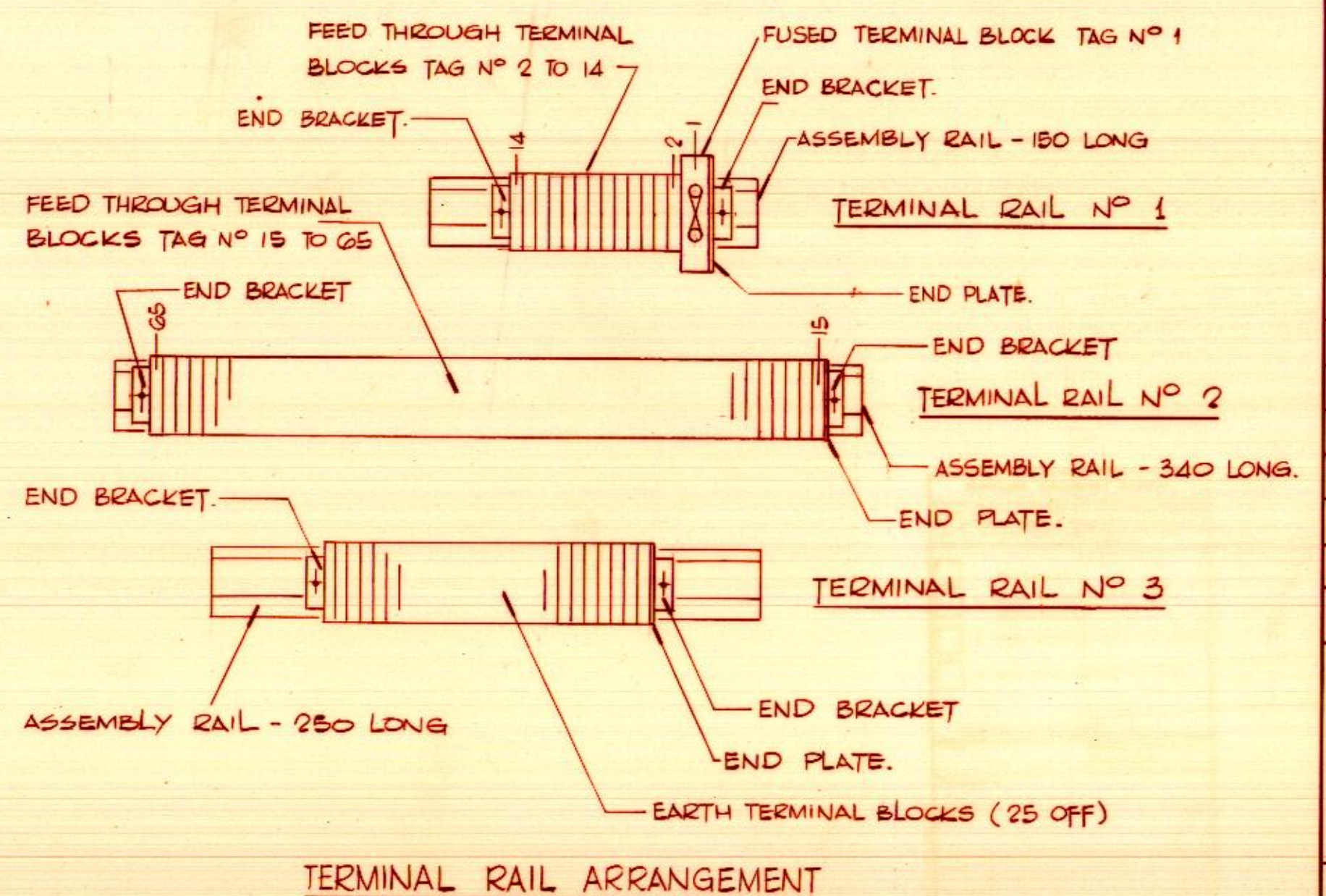
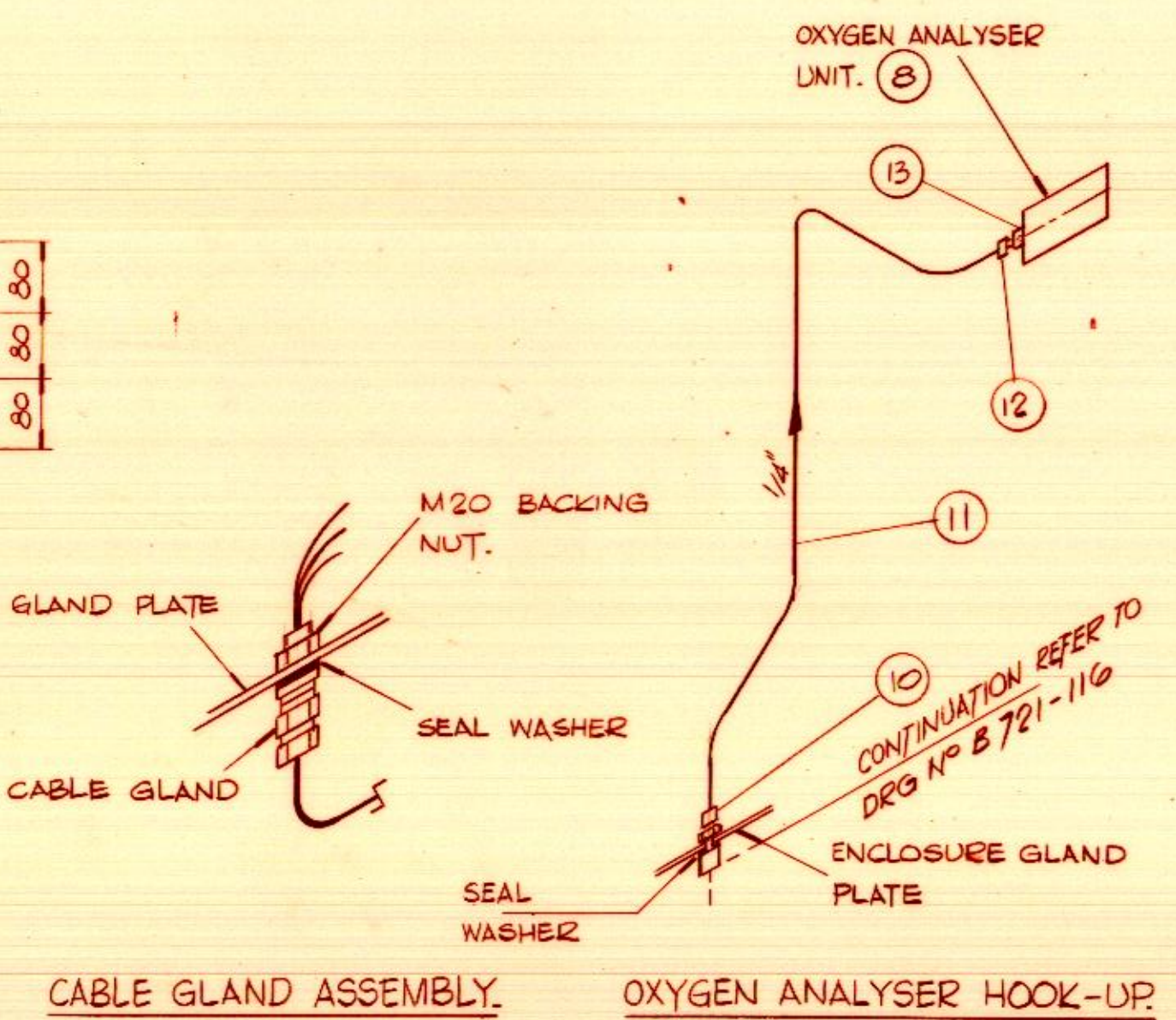
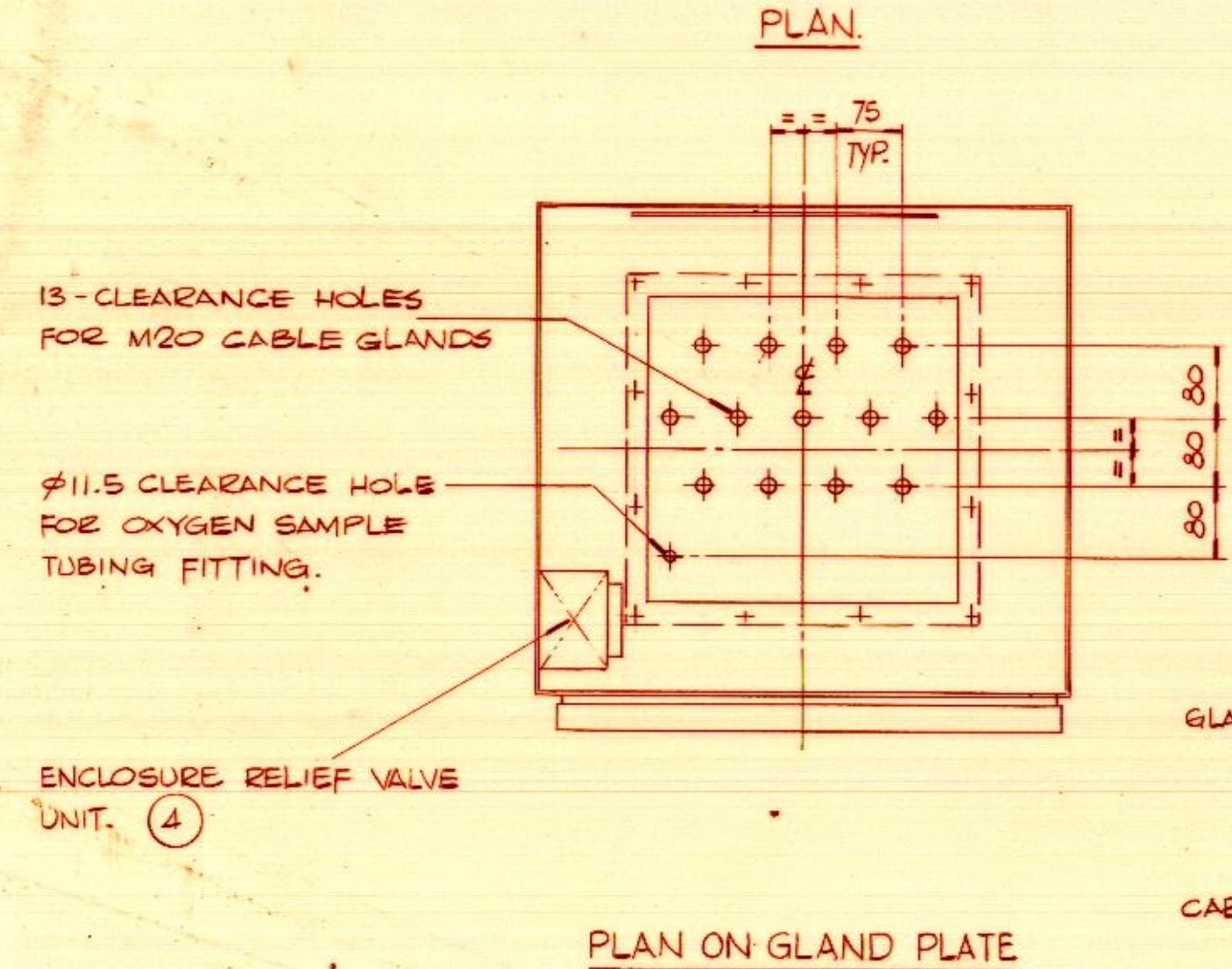
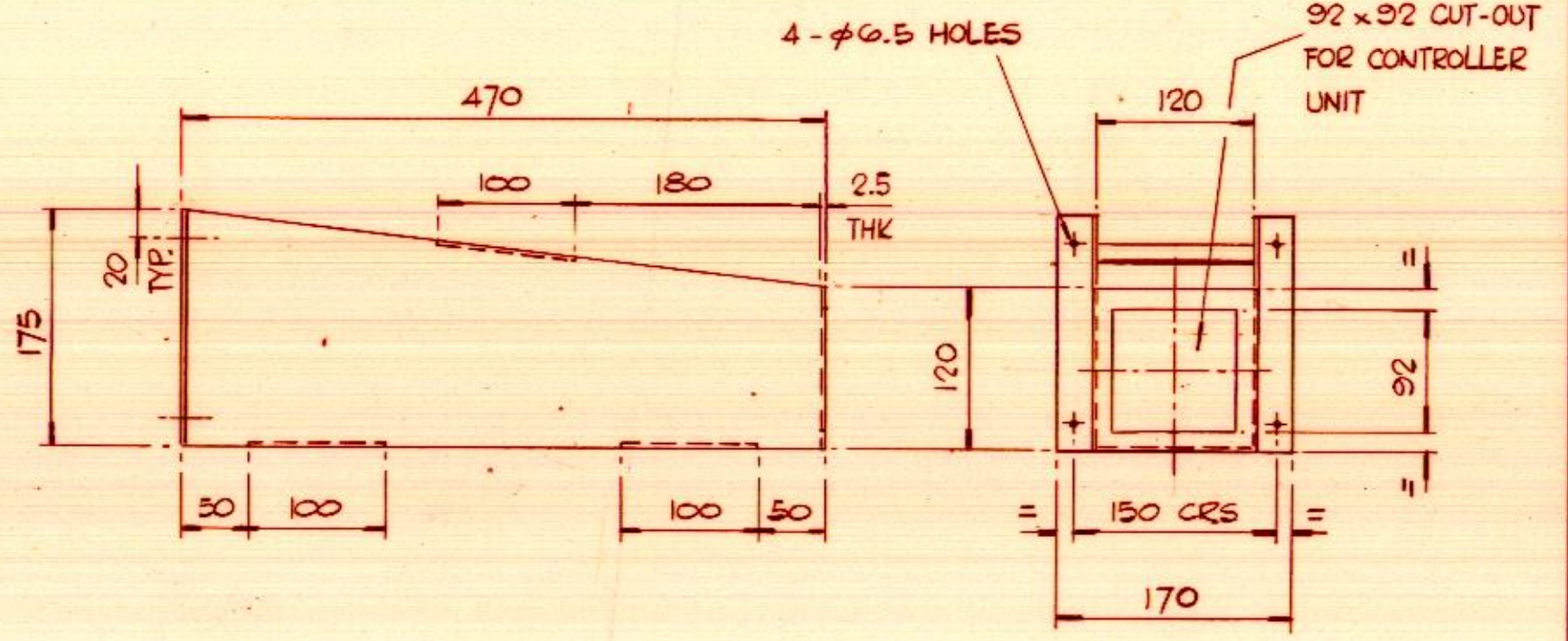
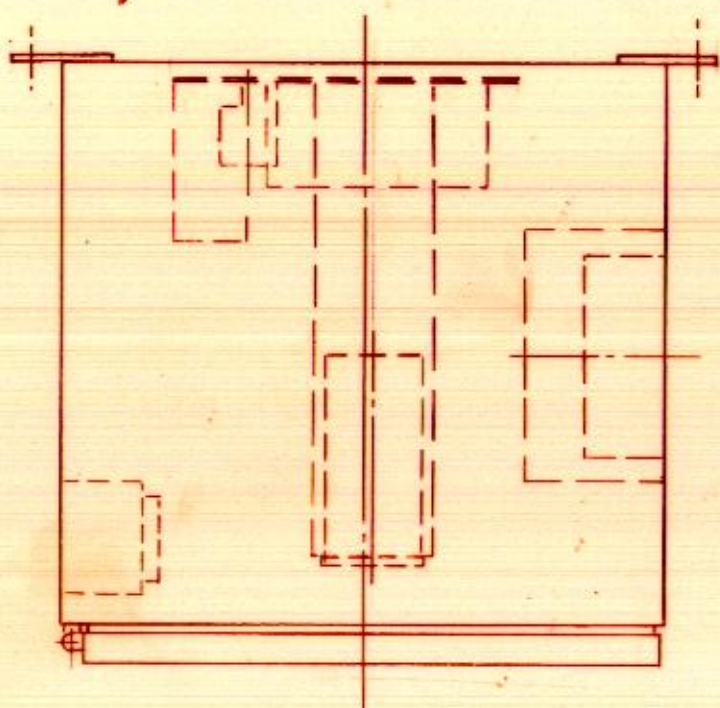
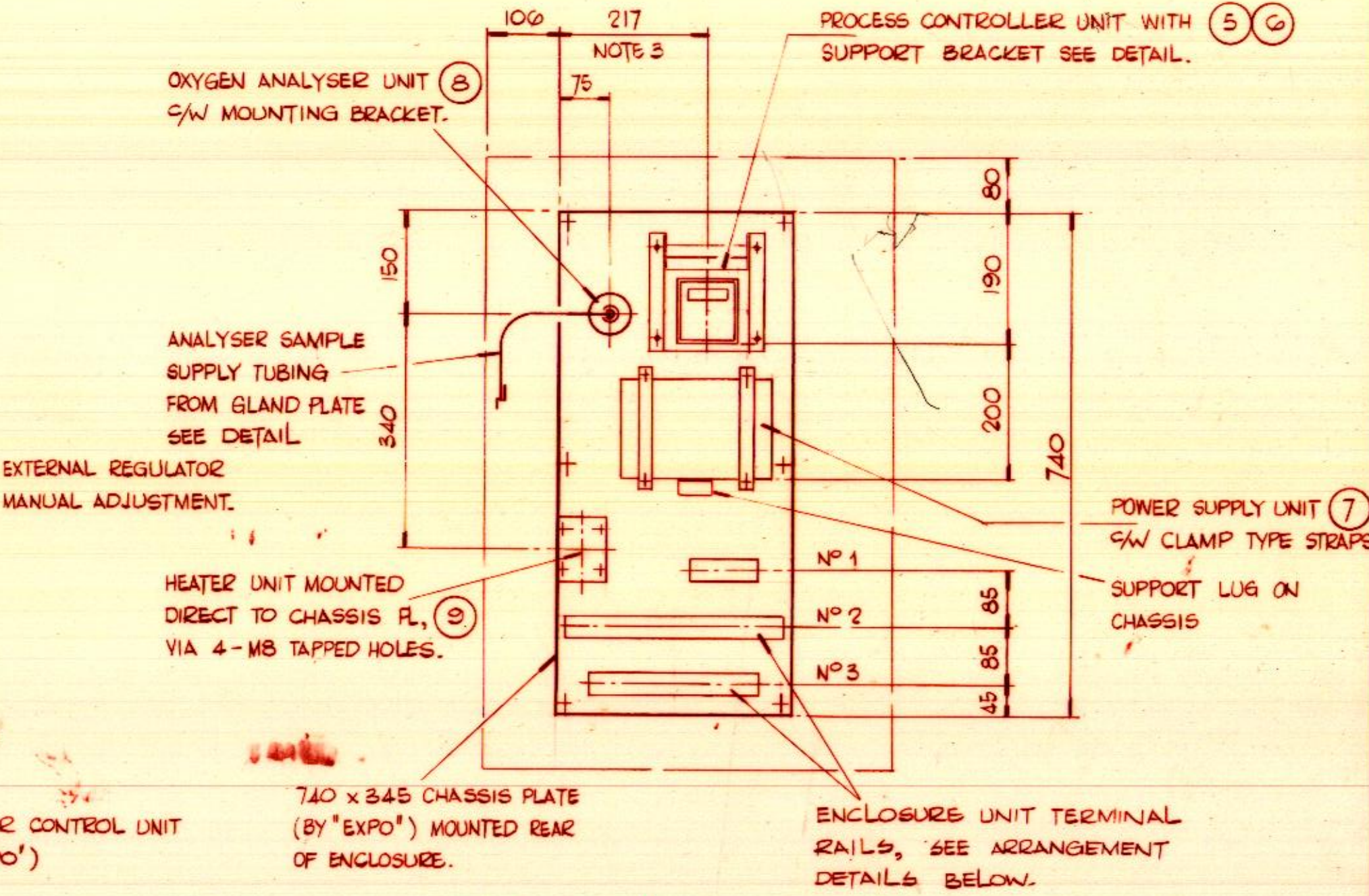
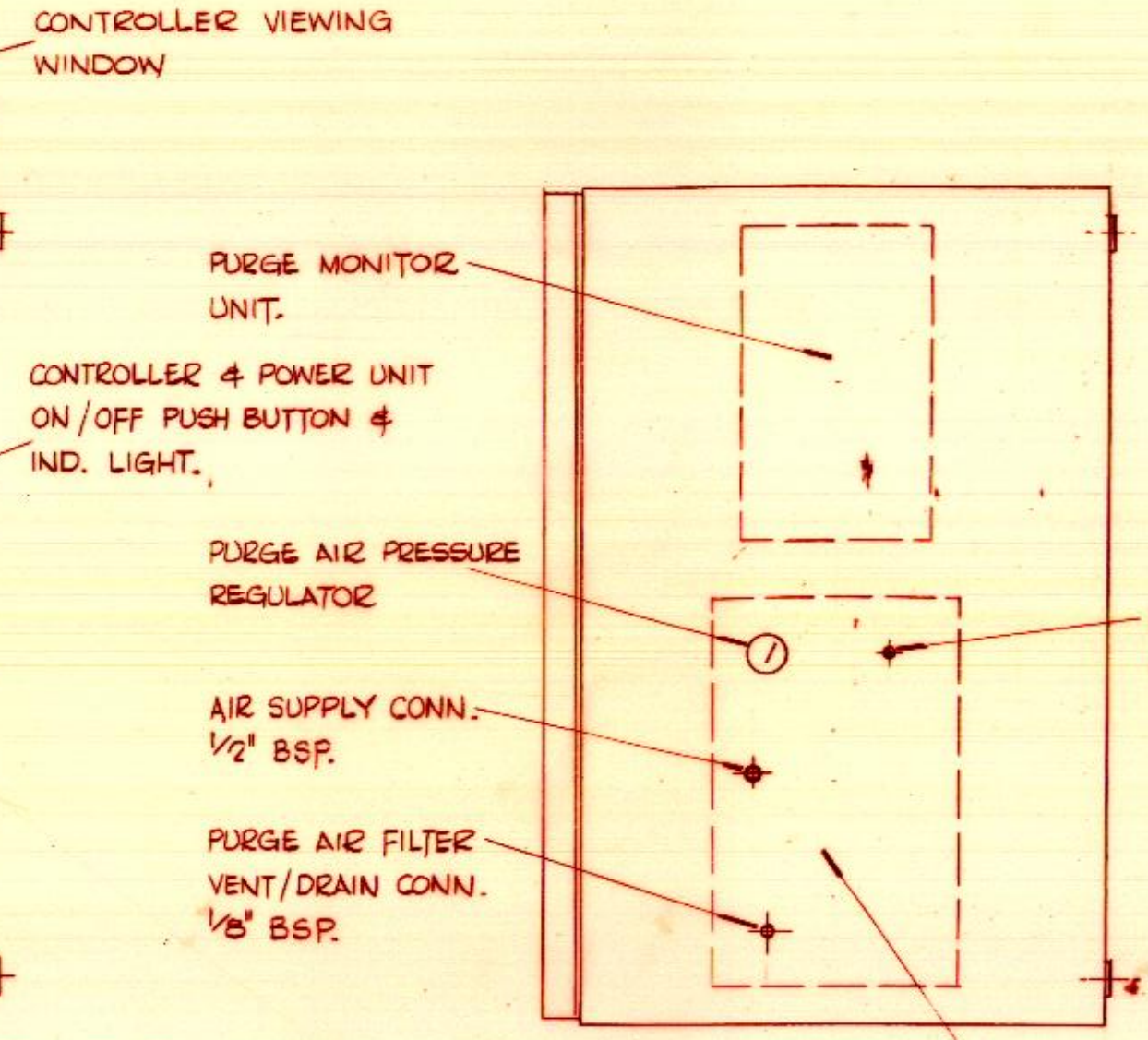
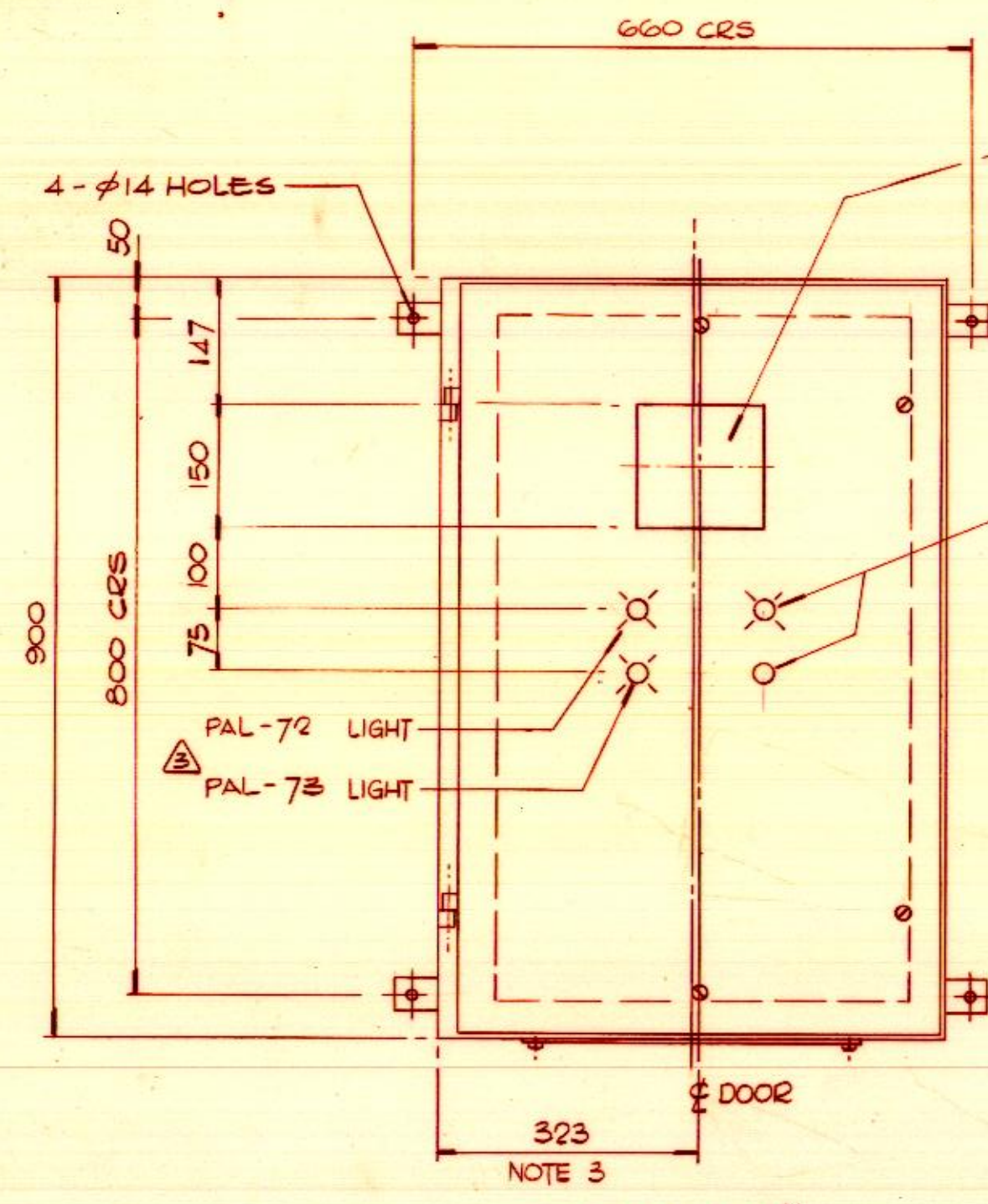

- NOTES:
- ENCLOSURE HOUSING SUPPLIED BY "EXPO SAFETY SYSTEMS LTD" FROM STANDARD UNIT RANGE, COMPLETE WITH ITEMS 2,3,4,4 FITTED AS STANDARD ITEMS, AND PUSHBUTTON WITH THREE INDICATING LIGHTS FITTED ON DOOR
 - ITEMS 5, 7, 8 & 9 SUPPLIED "FREE ISSUE" FOR SHOP TO FIT AS REQD ON ASSEMBLY OF SKID UNIT AND CONTROL PANEL.
 - PROCESS CONTROLLER UNIT TO BE ALIGNED WITH VIEWING WINDOW ON ENCLOSURE DOOR FOR READING OFF THE CONTROLLER INDICATORS.

SUPPLIER DOCUMENT REVIEW

1. HAVE ANY PROCS.

2. REVIEW AND RECOMMEND. HAVE ANY PROCS. CHANGED INDICATED.

3. REVIEW AND RECOMMEND. HAVE ANY PROCS.

4. REVIEW NOT REQUIRED. HAVE ANY PROCS.

Checked by: C. LAMAS Date: 7-6-84

Systems

Checked by: J. W. D. I. Date: 27/6/84

16436443-1-01 CRK/1

ITEM	QTY.	MATERIAL DESCRIPTION	DRG. No.	SPEC.
14	4	M6 SETBOLT C/W NUT & WASHERS.		
13	1	ADAPTOR 1/2" NPT F/MALE x 1/4" MALE		
12	1	MALE CONNECTOR 1/2" O.D. TUBE x 1/4" NPT		
11	1	1/2" O.D. x 0.085" THK WALL SMLS TUBING		
10	1	BULKHEAD FEMALE CONNECTOR 1/2" O.D. TUBE x 1/4" NPT		310 ST. ST.
9	1	ENCLOSURE HEATER UNIT. 0.3 KW		NOTE 2
8	1	OXYGEN ANALYSER UNIT. (G.S.I.)		NOTE 2
7	1	POWER UNIT. (G.S.I.)		NOTE 2
6	1	SUPPORT BRACKET. SEE DETAIL.		
5	1	PROCESS CONTROLLER UNIT. (G.S.I.)		NOTE 2
4	1	ENCLOSURE RELIEF VALVE UNIT.		NOTE 1
3	1	PRESSURE MONITOR UNIT.		NOTE 1
2	1	PURGE AIR CONTROL UNIT.		NOTE 1
1	1	PRESSURIZED ENCLOSURE 900 x 600 x 600.		NOTE 1

ISSUE DATE DESCRIPTION DRN. CKD. ENG. PROJ. ENG.

3 4/6/84 IND LIGHT TAG NOS REVISED. FINAL CERTIFIED RFS [initials]

2 18/6/84 REDRAWN. ISSUED FOR APPROVAL RFS [initials]

THIS INFORMATION IS CONFIDENTIAL AND THE PROPERTY OF KALDAIR LIMITED AND IS RELEASED ON CONDITION THAT NONE OF THE INFORMATION SHALL BE DISCLOSED TO ANY THIRD PARTY OR REPRODUCED IN WHOLE OR PART WITHOUT THE PRIOR CONSENT IN WRITING OF KALDAIR LIMITED.

Kaldair Limited

TELEPHONE 01-751-6191
TELEX 938671
England.

Astronaut House,
Hounslow Road, Feltham,
Middlesex TW14 9AD,
England.

CLIENT BECHTEL G. B. LTD.
CLIENT ORDER No. 30/24/0014/16436/493/V/01 LAC
PROJECT HAMILTON BROS - DUNCAN.
KALDAIR JOB No. 0721

ISSUE STAMP: 4 ISSUED 5 JUN 1984

TITLE: NITROGEN GENERATOR UNIT. DETAIL OF CONTROL CABINET ASSEMBLY.

SCALE: 1:7.5

DRG. No. B 721-107



UNLESS OTHERWISE STATED FLANGE BOLT HOLES TO BE EQUI-SPACED ABOUT MAIN CENTRE LINES.

THIRD ANGLE PROJECTION

IF IN DOUBT ASK DO NOT SCALE

WELD SYMBOLS TO BS 499 PART 2 LATEST EDITION FILLET WELD DIMENSIONS DENOTE LEG LENGTH.

TOLERANCES UNLESS OTHERWISE STATED

ORIENTATION ± 1.0 DEG.	0 TO 100mm ± 1.5mm
SQUARENESS ± 0.5 DEG.	OVER 100mm ± 3.0mm

56. DR-DR-4577
TONG CONG TY DAK DK
P/VEP